

IMPORTANT NOTICE

Please read the Operating Manual carefully before attempting to install or service the device! **AWENTA shall not be liable for any damage resulting from incorrect operation, non-intended use or unauthorized repair or modifications of the product.**

The Operating Manual and the installation instructions contained in it are an essential part of the product equipment. The Operating Manual specifies important technical information and instructions for the operating safety of the device. Carefully read the installation instructions in the Operating Manual. Keep the Operating Manual available for future reference. A copy of the Operating Manual can be downloaded from www.awenta.pl

Warnings

The following safety symbols show important safety information. Follow all safety regulations and the safety symbols shown in the Operating Manual to avoid injury and hazards.



Danger!



Electrocution hazard
– high voltage!



Attention
rotating elements!

Safety precautions:

- This product can be used by children at least 8 years old, by people with impaired physical and/or mental abilities, and by people without any experience in or understanding of the operation of the product, if supervised or instructed by a competent adult in the safe use of the product so that they understand the relevant operating risks. This product is not a toy and children should not play with it. Children should not be allowed to clean or maintain the product without supervision of an adult.
- The device is intended for permanent installation and connection with the building electrical system. The building electrical system connected to the

fan must be capable of breaking live voltage contact on all switching poles to fully isolate the fan from power during Category III overvoltage conditions, in accordance to applicable electrical engineering regulations.

- The device is designed for installation at a substantial height, i.e. 2.3 m above the floor. The fan shall only be installed in a position and an orientation specified in the Operating Manual, given the necessary entry of the power cable into the fan housing.

- Before servicing the device, isolate it from the mains voltage with the circuit breaker. Secure the circuit breaker against inadvertent operation.
- The fan installation design must prevent reverse flow of flue gas into the room from open flue gas exhaust ducts and appliances operated with open flames.
- Never attempt to modify or alter the device without authorization.
- Before installing the fan, verify the load bearing capacity of the installation substructure. Improper installation fastening may result in damage or failure of the fan and hazards to the people nearby.



The device may become dangerous if it is misused or installed by an untrained personnel.

Scope of use and work conditions

- The recuperator is intended for pumping of normal air or air containing some dust (the size of particles < 10 µm), with low aggression and humidity levels, in a temperate climate.
- The device may be used only if installed permanently, inside a building and if lack of access to the power supply cable is ensured.
- Acceptable work temperature scope of the device: from -20°C to +40°C.
- The device is compliant with IPX4 protection level, electricity protection class: II.
- The tool should be used only in accordance with its intended purpose and in accordance with the marking on the rating plate.
- **The fan should be connected with the fixed electric wiring system with NYM-O 2x1,5 mm² (H07V-K 2x1,5mm²) cable with a maximum external diameter of 8 mm.**
- The recuperator may not be used for the purpose of pumping of air containing:
 - viscous contaminants, which may settle on the device,
 - caustic contaminants, which may have an adverse influence on the device,
 - contaminants of mixtures of combustible substances in the forms of gases, steams, mists and dusts, which, mixed with air, may form an explosive atmosphere.
- Control system may not allow extreme works including frequent activations and shutdowns.
- The device should be mounted in an external partition / wall, in an adequate distance from the sources of contaminants (chimneys, flue gases etc.) so that exhausted / supplied air is free from contaminants.

- The device should be mounted in such a way that it deflects 2-5° from the horizontal position towards the outside. **It is prohibited to mount the device in a vertical position (in a ceiling, roof).**

Transport and storage

- The device should be stored in an original packaging, in a dry place protected against precipitation.
- The temperature at the place of storing and transport should be maintained between -20°C and +40°C.
- Avoid strokes and surges. The fans should be transported in an original packaging.
- In the case of storing period lasting longer than 1 year, you should check, before mounting, whether the bearings of the engine function properly by rotating the rotor using your hand.
- The disposal should be carried out in a proper and environmentally sound manner, in accordance with legal provisions.
- The damages caused by an improper transport, storing or activation should be demonstrated and are not subject to guarantee.

OPERATION DESCRIPTION AND EQUIPMENT

Operation description:

HRV recuperator is equipped with aluminium regeneration heat exchanger. Recuperation of the heat lost during the ventilation process is possible due to the duplex direction work of the fan. The device works alternately:

- Exhaust cycle (the heat from the stream of the exhaust air is accumulated in the exchanger),
 - Supply cycle (the heat accumulated in the exchanger is emitted to the stream of supplied air).
- The time of each cycle is 60 s.

HRV devices are equipped with engines with two rotational speeds. The change in the direction of air flow is automatic.

Available equipment options:

Standard (index without an additional marking). *The models in standard version should be connected in accordance with connection scheme in the Fig. 3.*

The fan is activated with a separate on-switch constituting an element of electric wiring system of a building (it is not an element of the device). The change of the rotational speed takes place alternately, after subsequent pulls of the pull switch.

Remote (index ended with "P" letter). *The models equipped with a remote should be connected in accordance with the connection scheme in the Fig. 4.*

The fan is activated with the button on the remote (Fig. 2). The change in the rotational speed takes place directly after pressing the adequate button on the remote. After switching on and switching off again, the device works based on the gear that has been set the last time.

CONSTRUCTION AND MOUNTING

The basic elements of the device:

1. Two-speed supply-exhaust fan.
2. Aluminium accumulation heat exchanger.
3. Air filter.
4. Telescopic section of air duct, adjustable: 335 - 540 mm.
5. End of the air duct.
6. Remote control (*in the case of HRV100P / HRV125P model*).



Only trained personnel may, in accordance with the applicable provisions, mount, connect to power supply and activate the fan!

Mounting process

- Precisely specify the place, where the device is to be installed.
- Prepare power supply cable. **Use NYM-O 2x1,5 mm² (H07V-K 2x1,5mm²) with the maximum diameter of 8 mm.**

CAUTION: Before commencing the works, you should make sure that the power supply cable is not live.

- Measure and create an opening in an external wall for the telescopic duct of the device.
- CAUTION: The diameter of the opening should be at least 10 mm larger compared to the external diameter of the duct.**
- Place the telescopic duct (4) together with the exchanger (7) and filter (6) in the external wall and seal with foam or cotton wool.
The duct should be mounted in such a way that it is slightly deflected towards the outside. The exchanger together with the filter should be located at least 10 cm away from the edge of the telescopic duct.
- Insert the end of the duct (5) in the telescopic duct and then fasten it to the wall with the use of mounting pins.
- Remove the front panel of the fan (1) and the cover of electronics (2).
- Drag the electric cable in double insulation through the cable grommet. Move the cable until it is possible to connect it to power supply clamps.

Before fastening the fan: remove the foreign objects from the inside of the fan; check, whether the rotor rotates freely by making it move with your hand.

- Insert the fan (3) into telescopic duct and then fasten it to the wall with the use of mounting pins.
- CAUTION: The grommet of the cable should be located at the bottom.**
- Remove the external insulation from the cable, remove the insulation from the wires over 4 mm.
- Place the cable and connect it in accordance with the connections scheme of the installed model.
- Check whether the conductors of the cable are strongly connected to the clamps.
- Check whether the fan is fastened in a solid manner and the electric wiring system is proper.
- Put on and screw the cover of electronics (2).
- Check the sealing of the connection cable.
 - The connection cable must be secured in a way ensuring that in the case of flooding, no water flows along the cable to the live parts.
- Mount the front panel (1) constituting the protection against contact with the moving parts.



ATTENTION! A rotating impeller can crush your fingers! It is forbidden to start the fan without a protective mesh against touching the moving parts!

The first activation

The activation may take place only after all safety instructions had been checked and all dangers had been eliminated. After activation, check whether the fan works normally and whether the air flows in a proper manner. Observe the work of the fan (its loudness, vibrations, consumption of electricity, the possibility to control the rotational speed).

The device may be used only with the front panel and the end of the duct constituting the protection against the contact with the moving parts. The user is responsible for meeting the present norms and may bear the responsibility for the accidents resulting from the lack of protection elements.

Connecting to power supply

- Only qualified electricians may connect the fan to power supply and activate it for the first time.
- The adequate norms, safety provisions and technical conditions for the connections of the enterprise providing the electricity should be strictly followed!
- In this case, it is necessary to use mains multi-polar switch/isolation switch with a minimum 3 mm opening of a contact (PN-EN 60335-1)!
- The types of mains, voltage and frequencies have to be compliant with the data on the rating plate.

Dimensions

The dimensions of particular models have been presented in the figures: 5a and 5b.

MAINTENANCE AND CLEANING

Keeping the fan operational, maintenance

- During maintenance, you should use protective shoes and protective gloves!

- During all maintenance works, comply with the safety norms and OHS provisions (PN-IEC 60364-3).
- Before commencing the works on the fan, the fan should be powered off and secured against being activated again!
- Air ducts of the fan has to be free from foreign objects - danger caused by the thrown away items!
- Do not carry out maintenance, when the fan is working!
- If you can feel or hear excessive vibrations, you should commission authorised electrician to carry out a technical inspection of the product.
- The periods between the technical inspections depend on the level of soil of the rotor and filter, however the technical inspections should not be carried out less frequently than every 6 months!
- Check the rotor for cracks.
- **The manufacturer shall not bear any responsibility for the damages resulting from an inadequate repair.**
- In the device, there have been used engines equipped with ball bearings "lubricated for the entire period of use" the engine does not require lubrication.

Cleaning



**In the case of damaging of the insulation, there is a risk of electrocution!
Before you commence the cleaning, disconnect the fan from the mains completely and secure it against becoming connected again!**

- Clean the front panel and the visible parts of the casing with moist cloth.
- Do not use aggressive substances that dissolve lacquer!
- The use of pressure washer or water stream is prohibited!
- While cleaning, you should prevent the water from entering the interior of the electric engine or junction box.
- The cleanliness of the grilles at the inlet/outlet of the fan should be maintained on the ongoing basis.
- In the case of the filter becoming dirty, the fan should be disassembled, removed and then the filter should be washed with running water.
- Dry the filter before putting it inside again.

WARRANTY TERMS & CONDITIONS

1. The warranty period for the proper operation of the device is 2 years, from the date of sale.
2. The warranty rights and obligations will be void and null without demonstrating a proof of purchase (a receipt or an invoice).
3. The warranty covers all defects and damage attributable to the manufacturer.
4. Have your product delivered for warranty servicing to the manufacturer or the original seller.
5. The manufacturer undertakes to repair the product or replace it with a new counterpart within 14 days from filing your warranty complaint.
6. The warranty does not cover any of the following: damage to the product attributable to improper or unqualified installation, operation against the intended use, improper transport, storage and/or maintenance, any faults attributable to unauthorized repairs, or any accidental damage.
7. The warranty does not cover the installation or the maintenance of the product.
8. For all matters not provided for by this Warranty Certificate, the Polish Civil Code (Articles 577- 582) shall apply.

Do not dispose of waste electrical equipment with household waste.



The crossed-out wheeled bin symbol on this product means that it is waste of electrical and electronic equipment (WEEE) at the end of its operating life and shall not be disposed with household waste. The crossed-out wheeled bin symbol specifies that the product is subject to obligatory waste segregation schedules for proper disposal. The product is made from recyclable materials and components. The product user is required to return the product which has become WEEE to a WEEE collection unit.

The operators of WEEE collection units, including local WEEE locations, product resellers and other WEEE collection locations managed by local authorities form a proper waste disposal system. Proper WEEE disposal helps avoid harmful effects to humans and the environment from the risk caused by hazardous components this product may contain. The household plays an important role in contributing to reuse and recovery, including recycling, of used up appliances, and it is the stage where attitudes are created that impact the preservation of the common being the clean natural environment. Households are among the leading consumers of small appliances and equipment. A rational management of operation and disposal of small appliances and equipment will contribute to efficient recycling.

Rys.1
Fig.1
Изобр.1
Obr.1
Abb.1

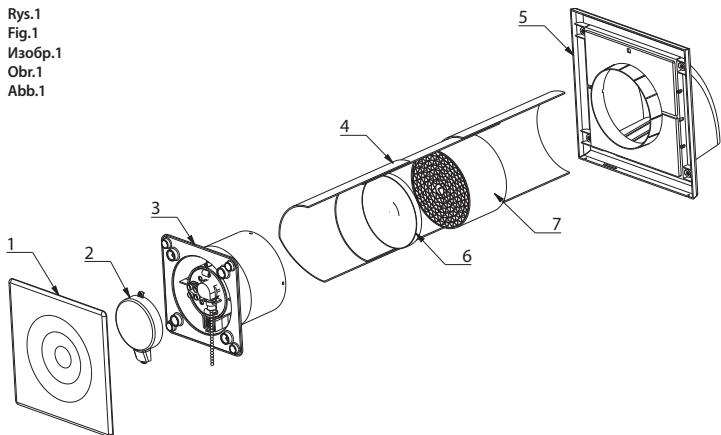

Rys.2
Fig.2
Изобр.2
Obr.2
Abb.2

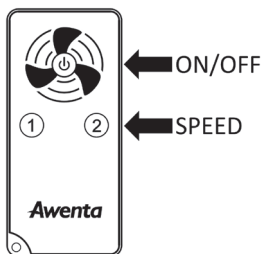

Rys.3
Fig.3
Изобр.3
Obr.3
Abb.3

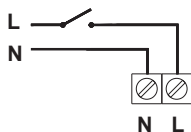

Rys.4
Fig.4
Изобр.4
Obr.4
Abb.4

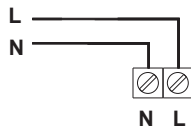

Rys.5a / Fig.5a / Изаобр.5a / Obr.5a / Abb.5a (HRV100)

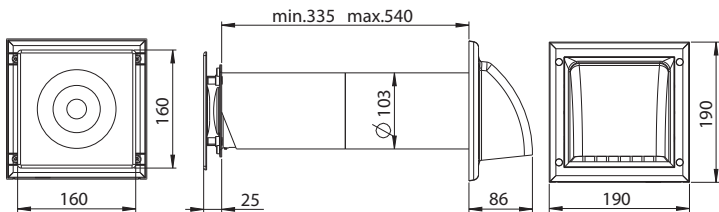

Rys.5b / Fig.5b / Изаобр.5b / Obr.5b / Abb.5b (HRV125)

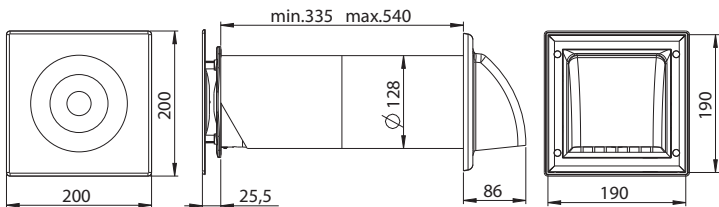

Awenta
SINCE 1989

Producent / Manufacturer / Производитель / Výrobce / Výrobca/Hersteller:

AWENTA E.W.A. Spółka Jawna

05-300 Mińsk Mazowiecki, Stojadła, ul. Warszawska 99, Poland

Tel: +48 25 758 52 52, + 48 25 758 93 92 fax: +48 25 758 14 62

e-mail: info@awenta.pl www.awenta.pl