

ENERGY BOX TO

Ceiling Type Heat Recovery Unit (Aluminium Plate)





PROHIBITED

- ◆ This unit has to be used under proper conditions according to its technical specification and design purpose. (Otherwise responsibility belongs to practitioner)
- ◆ Unauthorized personnel must not interfere in unit and/or must not use unoriginal spare parts. (Otherwise responsibility of failure that may occur belongs to practitioner)
- ◆ Do not install this product in a refrigerated warehouse, heated swimming pool or other location where temperature and humidity are significantly different. (Failure to heed this warning may result in electrical shock or malfunctioning.)
- ◆ Do not install this product where it will be directly exposed to rain. (Failure to heed this warning may result in electrical shock or malfunctioning.)
- ◆ Do not install this product in a location where acid, alkali or organic solvent vapors, paints or other toxic gases, gases containing corrosive components or high concentrations of oily smoke are present (Failure to heed this warning may result not only in malfunctioning but also fire, power leakage and electrical shock.)
- ◆ Do not use this product outside the range of its rated voltage and control capacity.



ATTENTION

- ◆ Install this product in an environment where the temperature ranges from -10 °C to +40 °C and the relative humidity is less than 60%. If condensation is expected to form, heat up the fresh outside air by a duct heater etc.
- ◆ Select an adequately sturdy position for installing the product and install it properly and securely.
- ◆ Use the designated electrical wires for the terminal board connections and connect the wires securely so that they will not be disconnected. (Failure to ensure proper connections may result in fire.)
- ◆ When passing metal ducts through wooden buildings clad with metal laths, wire laths or metal, these ducts must be installed in such a way that they will not make electrical contact with metal laths, wire laths or metal sheets. (Power leakage can cause ignition.)
- ◆ The outside ducts must be tilted at a gradient (1/30 or more) downwards toward the outdoor area from the main unit, and properly insulated. (The entry of rain water may cause power leaks, fire or damage to household property.)
- ◆ Gloves should be worn while installation. (Failure to heed this warning may result in injury.)
- ◆ A dedicated circuit breaker must be installed at the origin of mains power supply. This circuit breaker must be provided with a means for locking (lock and key).
- ◆ Leave enough distance between the power supply and control panel cables, to avoid interference.



- ◆ This product must not be disassembled under any circumstances. Only authorized repair technicians are qualified to conduct disassembly and repairs. (Failure to heed this warning may result in fire, electrical shock or injury.)



- ◆ Connect the product properly to the ground. (Malfunctioning or power leaks can cause electrical shock.)



- ◆ An isolator switch having minimum contact gap of 3 mm in all poles must be provided as a means of disconnecting the power supply.

NOTE : The installations, which is not available for installation and operation manual, is out of guarantee.

In the event of unit failure and pre-commissioning checks to be made are determined as follows; after checking this information, please contact our company in case failure continues.

Controls



Make sure that the unit receives power and electrical grounding is made!

Make sure that the electricity cables are drawn from in the correct cross section!
(Please check whether there is heating on cables or not.)

Please check whether the cables in unit control panel are shielded (shielded magnetic field) or not; make sure shielding is grounded. If not, please change them!

Make sure that fresh air and exhaust air filters are clean and they do not block the flow of air!

Make sure there is the connection of drainage on the unit, check any possible clogging in drainage line and clean if necessary!

Please check whether the diameter of the air duct connection of the unit and the diameter of the spigot are the same. If the duct connection is smaller, change it with the correct one.

Make sure the electrical connections of the unit are made as suggested on the unit and in this guide, check if there is incorrect connection.

Make sure during the installation of the unit there is enough space for the service and if there is not enough space, re-install again.

In extremely cold climate applications, frost may occur on the exchanger, apply electric heater in fresh air intake section of the unit to get the temperature to -8 °C and above.

After installing the unit, make sure that it does not create an abnormal sound or vibration, if there is, make sure that rubber pads are used.

ENERGY BOX - TO	350	800	900	1.400	1.800	2.400	2.800	3.500	4.600	5.700
Air Flow (m³/h)*	350	780	930	1.440	1.800	2.450	2.780	3.500	4.650	5.735
Supply Voltage (V/Hz/Ph)	230 / 50 / 1 ~									
Max. Power Consumption (W)	96	204	310	450	450	1.030	1.030	940	1.360	2.600
Max. Operation Current (A)	0,44	0,9	1,36	2	2	4,5	4,5	4,1	6	11,6
Max. Sound Pressure** (dB)	44	42	43	46	42	52	52	44	50	52
Unit Weight (kg)	41	43	43	59	80	99	120	125	155	175
Filter Class	G Class Synthetic Filter According to EN 779									
Electric Heater (kW)***	1	2	3	3	5	7	8	10	13	16
E.Heater Supply Voltage (V/Hz/Ph)	230 / 50 / 1 ~					400 / 50 / 3 ~				
Heater Coil (90/70°C) - (kW)	-	2,9	4,3	6,4	8,3	11,4	14,2	17	22,8	26,9

*External static pressure is 0 Pa.

**Measured at 1,5 m distance to the unit @ 250 Hz.

***Electrical heater and heater coil are optional. Electrical heaters shall be used before the fresh air inlet of the unit to preheat air where outdoor air is below -3°C and condensation can occur. Also in humid climates return air ducts must also be insulated against condensation.

UNIT DIMENSIONS

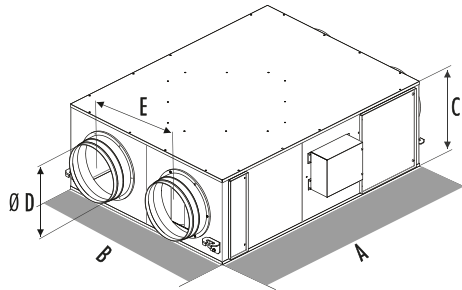

ENERGY BOX - TO	A	B	C	E	Ø D	S
350	872	550	280	273	Ø 160	500
800	930	675	335	336	Ø 200	500
900	930	675	335	336	Ø 250	500
1.400	1.072	826	375	412	Ø 250	500
1.800	1.192	980	430	488	Ø 300	600
2.400	1.335	1.120	430	558	Ø 355	700
2.800	1.570	1.160	540	577	Ø 355	700
3.500	1.570	1.160	540	577	Ø 355	700
4.600	1.805	1.240	640	622	Ø 450	750
5.700	2.150	1.350	680	675	Ø 500	750

* All measurement values are mm.

* The gaps of the maintenance area values are specified as "S" on the table. ("Installation" is on page 5.)

Alternative 1

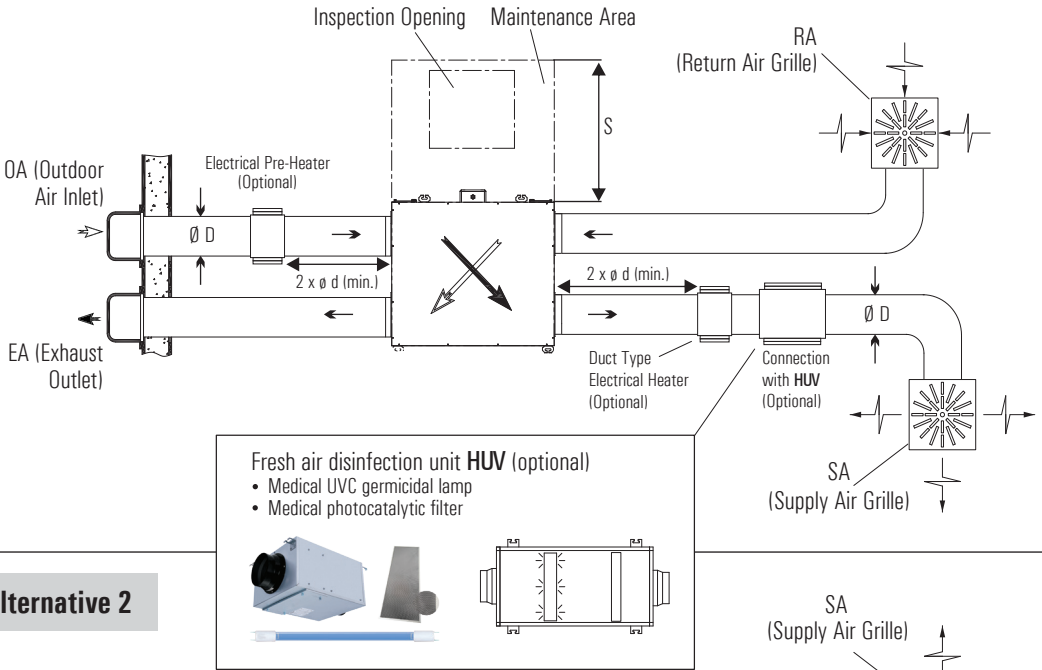

Alternative 2

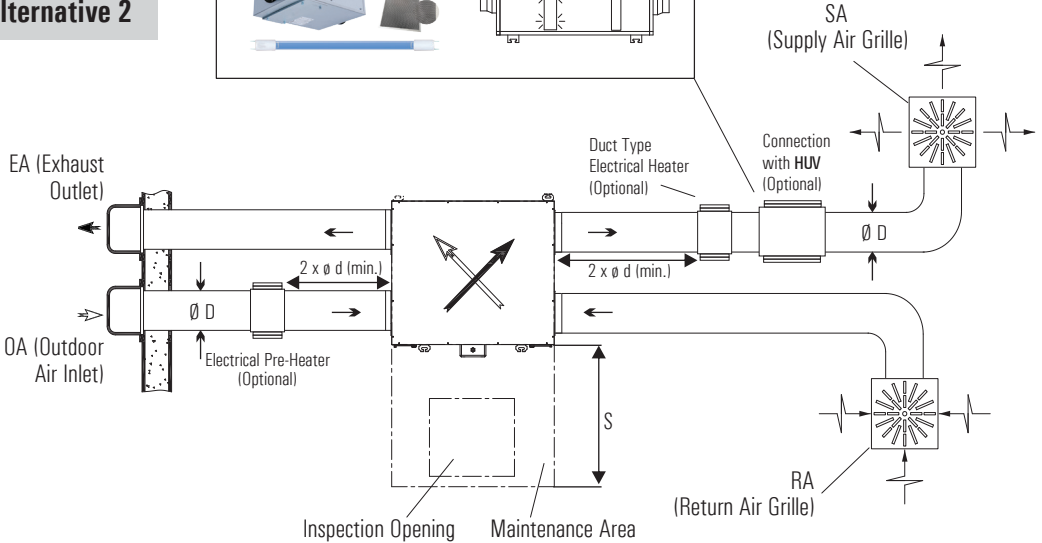

TOP VIEW : The gaps of the maintenance area are specified as "S" on the technical picture.
("Unit Dimension" is on page 4.)

* Drain pipe must be installed.

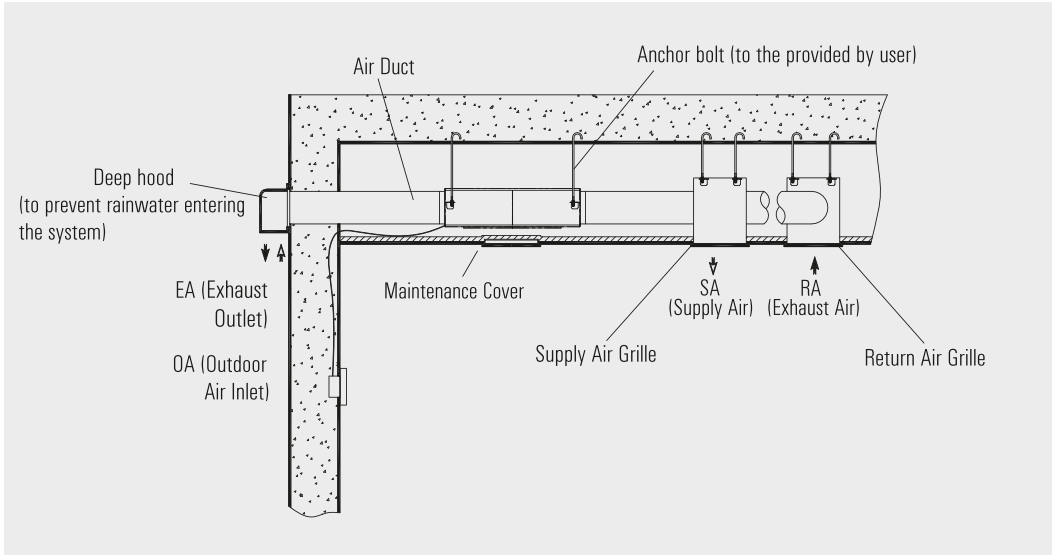



Check these warnings before installation.

Extremely Sharp Bends

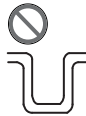

Multiple Bends



Bends right next to the outlet

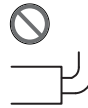

Extreme Reduction in the diameter of the connected ducts

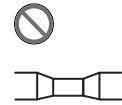

- 1- Install the electric heater at a distance of two times away from duct connection diameter.
- 2- Connect the drainage line with downward slope.
- 3- Water condensed in the exchanger should be discharged by connecting 10mm. diameter drain hose to the drain outlet under the unit.

- 4- The applications which can prevent the flow of water in the drainage line should be avoided.
- 5- The drainage line shall never be moved to an upper level than the drain pan.

Preparing the sling bolts

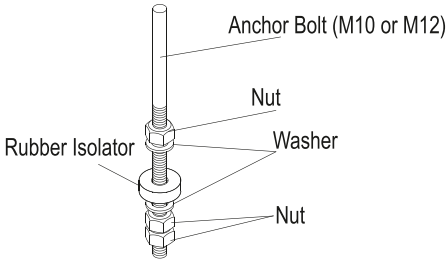

Hang the suspension bracket on the anchor bolts and adjust in such a way that the unit is installed horizontally. Tighten up securely using double nuts in order to prevent looseness.

! WARNING

Check the stability of sling bolts during the installation.

Attaching the duct connection flanges

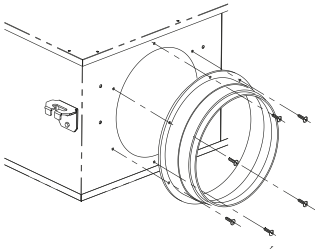

If the duct connection flanges are not connected to the unit, use the screws that can be found in the installation package to connect the flanges to the unit as the figure on the left.

! WARNING

Before attaching the duct connection flanges, check that no foreign matter has found.

Installation of the unit

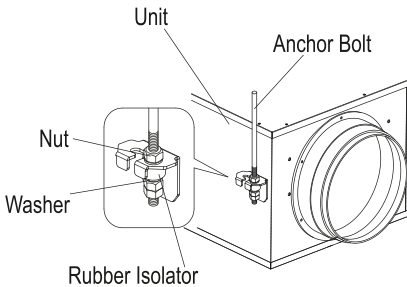

ENERGY BOX 350 - 3.500

Hang the unit on the anchor bolts and adjust in such a way that the unit is installed horizontally. Tighten up securely using double nuts in order to prevent looseness.

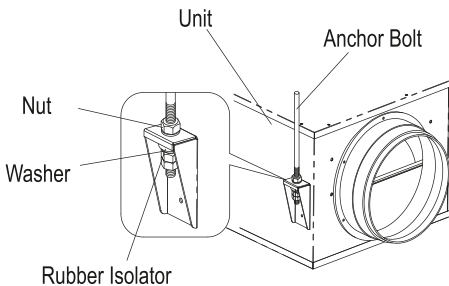

ENERGY BOX 4.600 - 5.700

Hang the unit on the anchor bolts and adjust in such a way that the unit is installed horizontally. Tighten up securely using double nuts in order to prevent looseness.

! WARNING

Do not handle the unit in such way that force will be applied to the control box when suspending the main unit from the ceiling.

Unit Model ENERGY BOX - TO	Unit Voltage (V)	Unit Power Input (kW)	Current (A)	Fuse (A)	Cable Cross - Section (mm ²) for 50M and PF=0,8
350	230	0,10	1	1	1,5
800	230	0,20	1	2	1,5
900	230	0,30	2	3	1,5
1.400	230	0,45	3	3	1,5
1.800	230	0,45	3	3	1,5
2.400	230	1,03	6	10	1,5
2.800	230	1,03	6	10	1,5
3.500	230	0,94	6	10	1,5
4.600	230	1,36	8	10	1,5
5.700	230	2,60	14,2	16	1,5

Cable Cross-Section Formulas

1

$$I_{\text{current}} = \frac{P}{U \times \text{Cos}\phi}$$

$$I_{\text{cable}} > I_{\text{current}}$$

2

$$\%e = \frac{100 \times P \times L}{k \times S \times U^2}, \quad S = \frac{100 \times P \times L}{k \times \%e \times U^2}$$

$$\%e = \%3$$

3

$$I_{\text{cable}} > I_{\text{fuse}} \geq I_{\text{current}}$$

$$\text{Cable Cross-Section } S = \text{Max } (S1, S2, S3, 1,5 \text{ mm}^2)$$

P : Power

I : Current

U : Voltage

S : Conductor cross section

k : Conductor coefficient

L : Conductor length

%e: The voltage drop

Example of Cable Cross-Section Calculation

P : 2,6 kW

L : 50 m

U : 230V

%e: %3

PF: Cosϕ : 0,8

k : 56 m / Ω

1

$$I_{\text{current}} = \frac{2.600 \text{ W}}{230 \times 0,8} = 14,2 \text{ A}$$

The cable will be used, is selected from the cable cross-section table so that the equivalent ampere value in the table should be higher than calculated "I_{current}" value.

$$S1 = 1,5 \text{ mm}^2$$

2

$$\%e = \%3$$

$$S = \frac{100 \times 2.600 \times 50}{56 \times 3 \times 230^2} = 1,46 \text{ mm}^2$$

$$S2 \geq 1,46 \text{ mm}^2 \geq 1,5 \text{ mm}^2$$

$$S2 = 1,5 \text{ mm}^2$$

3

$$I_{\text{cable}} > I_{\text{fuse}} \geq I_{\text{current}}$$

$$I_{\text{cable}} > 16 \text{ A} \geq 14,2 \text{ A}$$

"I_{fuse}" which will be higher than "I_{current}", is selected.

The cable will be used, is selected from the cable cross-section table so that the equivalent ampere value in the table should be higher than selected "I_{fuse}" value.

$$I_{\text{cable}} = 24 \text{ A}$$

$$S3 = 1,5 \text{ mm}^2$$

$$\text{Cable cross-section } S = \text{Max } (S1, S2, S3, 1,5 \text{ mm}^2)$$

$$S = \text{Max } (1,5, 1,5, 1,5, 1,5)$$

$$S = 1,5 \text{ mm}^2$$

Speed Control Switch Electrical Connection Diagram (TO units Electrical Connection Diagram)

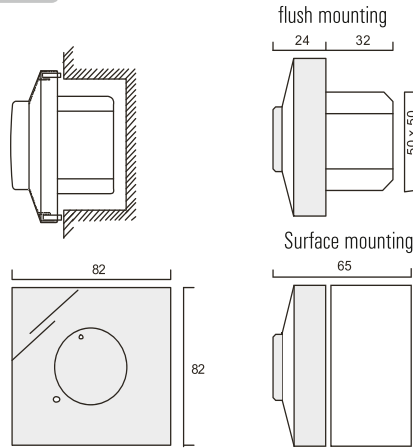
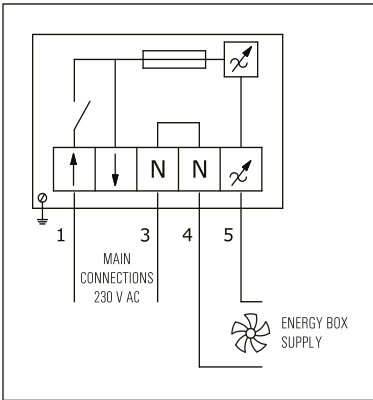

Dimensions in mm.

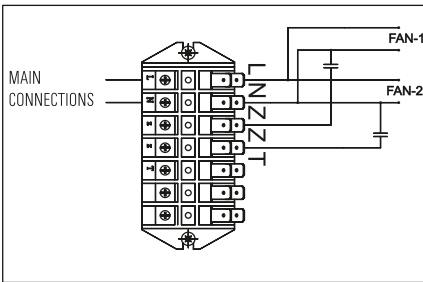

INTERNAL CONNECTION UNIT / DO NOT CHANGE

To switch between the models, the fan speed setting **ENERGY BOX 350 - 3.500** in accordance with the scheme carry out the electrical connection.

! WARNING

Setting the fan speed switch is Mains connection. **ENERGY BOX** units connected to switch the fan speed setting.

RGS Control Panel Connector Diagram

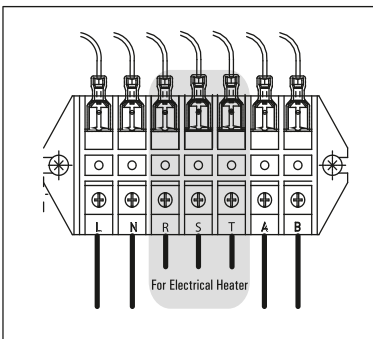

If RGS control Panel is used for the models between **ENERGY BOX 350 - 3.500**, make the electrical connection with the connector in the switch box as shown in figure (L and N terminals).

Unit can be controlled by the control panel with connecting control panel's A and B terminals as shown. If these is an electric heater, the connectors which are tagged as R,S,T must be supplied by three-phase energy.

! WARNING

Grid connection must be done to the L and N (R,S,T if necessary) terminals. A and B terminals are room control panel connections.

1 STEP ELECTRIC HEATER WIRING DIAGRAM

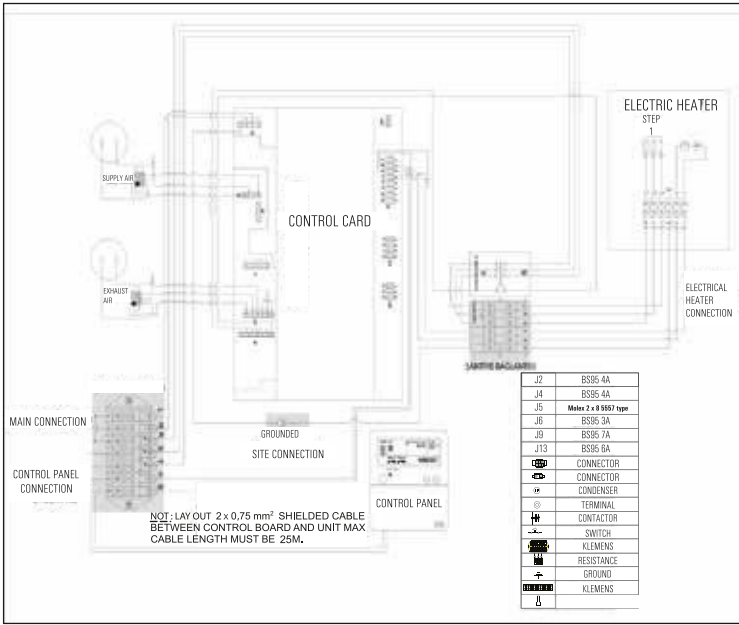

The figure shows RGS control panel which is used with 1 stepped three-phase electric heater in **ENERGY BOX 350 - 3.500** models.

WARNING!

Only qualified service may intervene in the unit's internal connection.

2 STEP ELECTRIC HEATER WIRING DIAGRAM

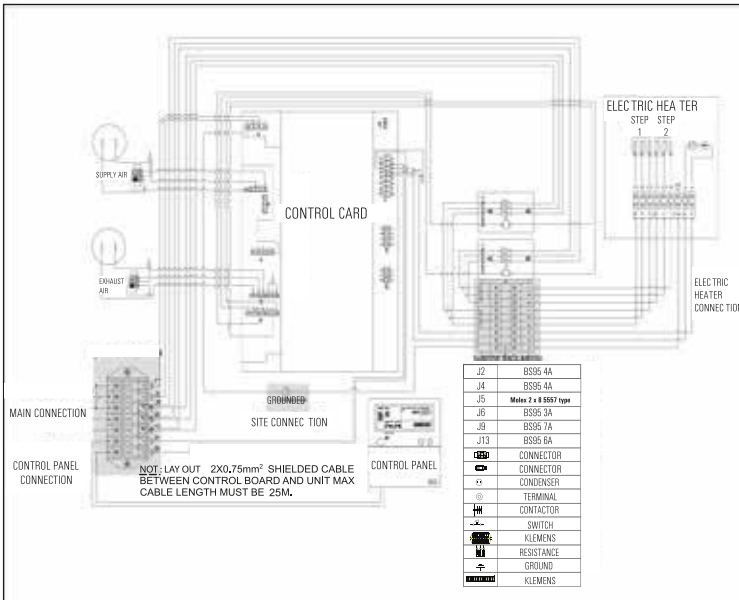

The figure shows RGS control panel which is used with 2 stepped three-phase electric heater in **ENERGY BOX 350 - 3.500** models.

WARNING!

Only qualified service may intervene in the unit's internal connection.

3 STEPS ELECTRIC HEATER WIRING DIAGRAM

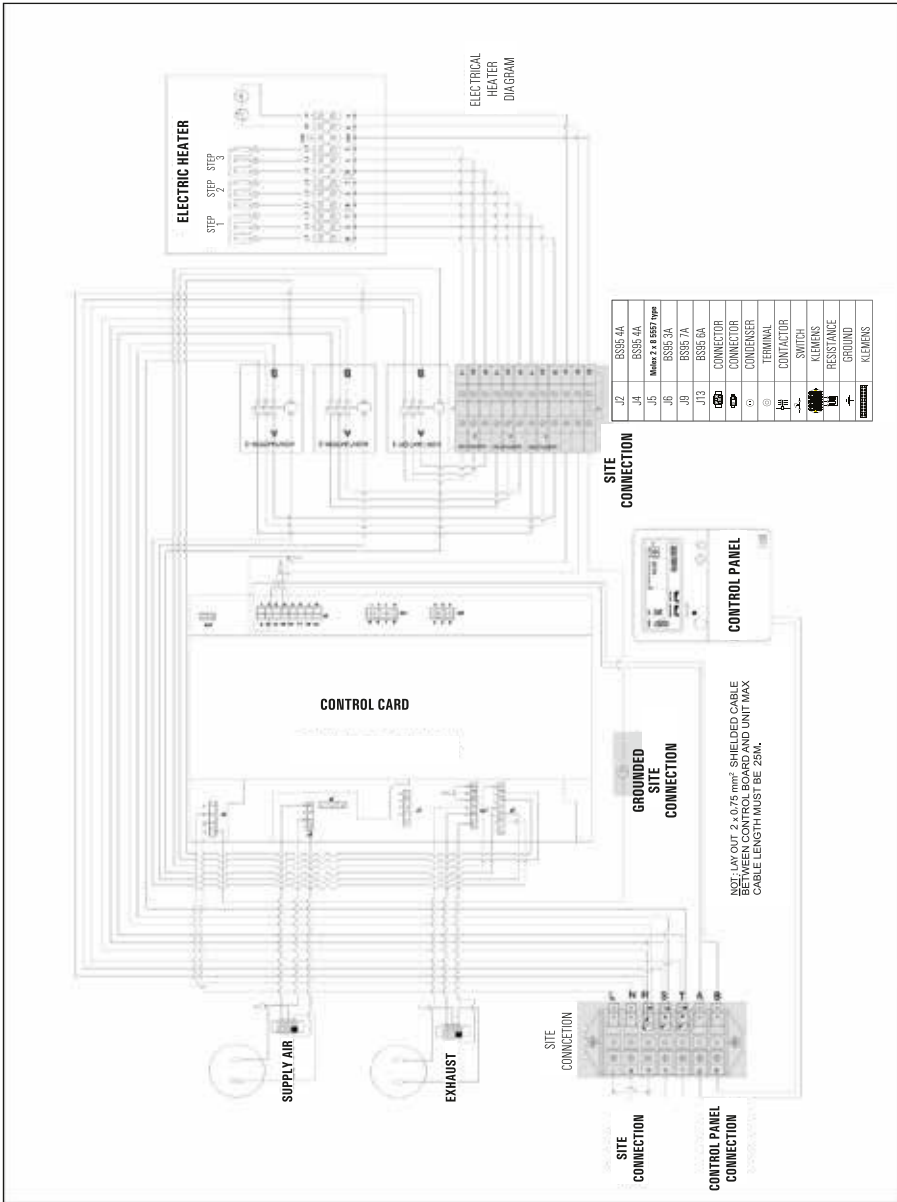

The figure shows RGS control panel which is used with 3 stepped three-phase electric heater in ENERGY BOX 350 - 3.500 models.

WARNING!

Only qualified service may intervene in the unit's internal connection.

Operation	Description	Basic Panel	Pro Panel
Fan Speed Control	3 steps fan speed control of supply and exhaust fan is available.	3 steps (2 fans) (High / Med / Low)	3 steps (each fans) (High / Med / Low)
Boost Function	<u>It is used for increasing fan speed:</u> Alternative-1: Via boost button on the control board Alternative-2: Via dry contact or light power input (230V) (like kitchen light, bathroom light etc.) on PCB board.	Standard	Standard
Filter Function	<u>There are 2 alternatives to control filters:</u> Alternative-1: It records run time of the unit and when set time expires, control board gives an alert for filter change. Alternative-2: Filter change time can be controlled with pressure switch mechanically. With this method, when filter needs to be changed control board gives an alert .	Standard Optional	Standard Optional
By-Pass Function*	Filtered fresh air is supplied indoor without passing in heat exchanger.	Optional	Optional
Electric Heater Control Function	Electric heater is controlled up to 2 steps automatically according to the set temperature and indoor temperature.	Optional Depends on Return Air	Optional Depends on Return Air or Room or Supply air
Sensor (VOD)	Fans are running continuously in accordance with CO ₂ sensor, air quality sensor or humidity sensor.	-----	Optional
Frost Protection Function	Where outdoor air is too low, this function is a protection method to prevent heat exchanger from freezing.	Standard	Standard
Pre-Heater Function	Where outdoor air is too low, fresh air is heated by a pre-heater before it enters into the unit. This function is a protection method to prevent heat exchanger from freezing.	Optional	Optional
External Control (BMS) Function	IN: Unit can be on/off via control board. OUT 1: Information of "unit status". OUT 2: Information of "fault".	Standard	Standard
Modbus Function	It controls all functions of unit via PC or central automation board.	Standard	Standard
Weekly Timer Function	Unit can be programmed to operate on certain periods of the week.	-----	Standard
Log Function	All possible working options of the unit can be recorded.	-----	Standard
Fire Function	It is used for changing working status of the unit in case of fire.	Standard	Standard
Warnings	- Filter change - Fan Fault - Pre-Heater Fault - Heater Fault	Standard (LED indicator)	Standard (Display error code)
Child-Proof Protection Function	It is used to lock the keypad.	Standard	Standard

Note: * This function is standard in some units.

Fan Speed Control Function:

Control board has 4 different fan speeds: "low", "medium", "high", "boost". These fan speeds are set to specific values by default. The maximum fan speed is "boost". If it is desired to change fan speeds, "low" and "high" set values can be changed by potentiometers on control board. If there is no potentiometer on the PCB, parameters of service menu can be used to change this function. Control board automatically set the value of "medium" by averaging "high" and "low" values.

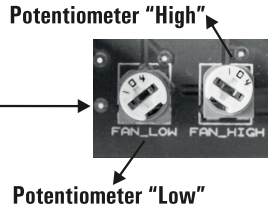
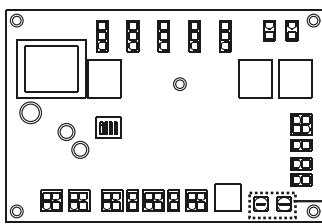

Service Parameter

- 26 Supply fan Low Speed Value
- 27 Supply fan Medium Speed Value
- 28 Supply fan High Speed Value
- 29 Extract fan Low Speed Value
- 30 Extract fan Medium Speed Value
- 31 Extract fan High Speed Value

Note: If "low" is set to the highest and "high" is set to the lowest value, unit continues to run according to default settings. Factory setting values can be changed by Pro Panel.

Filter Function

This function controls filter change time. There are 2 alternatives to control filters:

1. It records run time of the unit. Filter change time is set a particular run time by factory settings. When set time expires, control board gives an alert (red warning light flashes) for filter change. After filter cleaning is done, filter setting time can be reset by pressing simultaneously and on Basic Panel, hold and during reset time that appears on screen. When countdown is over, press on Pro Panel.

Note : Default run time set value is changeable on Pro Panel.

2. Filter change time can be controlled by pressure switch mechanically. With this method, when filter needs to be changed, control board gives an alert (red warning light flashes). After changing/cleaning is completed, warning light goes off automatically.

By-pass Function (Optional)

By-pass function only exists on units which have by-pass module. It is used when filtered fresh air is desired to be supplied to indoor without passing through heat exchanger (transition seasons). Control board decides whether by-pass module will be opened or not by controlling outdoor air temperature, return air temperature and set temperature values.

Note : To activate this function, turn "dip switch 3" on.

If there is no switch on the PCB, 97th parameter of service menu can be used to activate this function.(0=Enable)

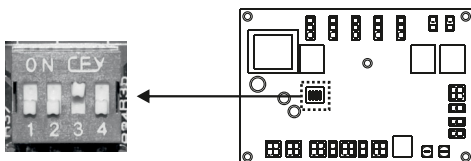

Electric Heater Control Function (Optional)

Electric heater control function only exists on units which have duct type electric heater. This function controls electric heater that is used to increase temperature of supply air. It runs due to the return air temperature and set temperature values. 1 or 2 steps electric heater can be controlled.

Note : To activate this function, turn “dip switch 1” on.

If there is no switch on the PCB, 9th parameter of service menu can be used to activate this function.(0 = Enable)

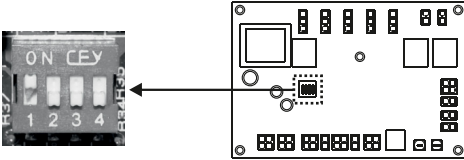

Heating Coil Function (Optional)

This function is used in units which have duct type hot water coils. It controls the hot water coil which helps to increase supply air temperature and works due to set and return air temperature. It can control 230V on / off valve connected to water coil.

Note : To activate this function, following must be applied :

- Turn electric heater function on. (Turn dip switch 1 on)
- Make short cut in between HT_Fault and HT_P_Fault inputs.
- Connect 230V on / off valve to 1. step electric heater control cable ends.

Cooling Coil Function (Optional)

This function is used in units which have duct type cold water coils. It controls the cold water coil which helps to decrease supply air temperature and works due to set and return air temperature. It can control 230V on/off valve connected to water coil.

Note : To activate this function, following must be applied :

- Turn electric heater function on. (Turn dip switch 1 on)
- Activate “Cooling Coil” on unit settings. (This can be done by authorized technical service or default in factory)
- Make short cut in between HT_Fault and HT_P_Fault inputs.
- Connect 230V on / off valve to 2. step electric heater control cable ends.

Frost Protection Function

Condensation occurs inside the unit where outdoor air temperature is below 0 °C. Heat exchanger can be damaged if condensation water freezes inside. Control board changes fan speed periodically to protect freezing.

Note : This function is active when outdoor air temperature is below -3 °C. Set temperature value is changeable on Pro Panel.

Pre-Heater Function (Optional)

This function helps to protect unit from freezing where outdoor air temperature is too low. It runs due to outdoor air temperature. 1 step electric heater can be controlled.

Note 1 : To activate this function, turn “dip switch 2” on.

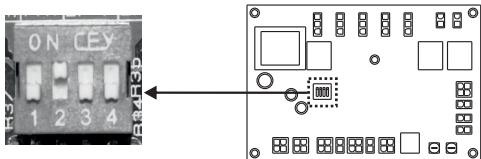

If there is no switch on the PCB, 95th parameter of service menu can be used to activate this function.(0 = Enable)



Note 2 : This function is active when outdoor air temperature is below 0 °C. Set temperature value is changeable on Pro Panel.

Boost Function

This function is used when large amount of exhaust and fresh air is needed (at the time of using kitchen/bathroom/wc, etc.) while ventilation is still going on. There are 2 boost functions on controller. One of them is on control panel, the other one is on control board:

1. “Boost” function is activated by pressing  on Basic Panel and  on Pro Panel for 3 seconds. After unit runs at boost speed (maximum speed) and during boost time (15 minutes) , it begins to run at the speed value that is set before boost function is activated.
2. There is one dry contact relay input and one 230V input on control board. If one of these inputs is activated, unit begins to run at “boost” speed. When activated input is passive again, unit begins to run at the speed value that is set before boost function is activated.

Note 1 : Boost speed and boost time are changeable on Pro Panel.

Note 2 : During operating at boost function on Basic Panel, “high” (H), “medium” (M) and “low” (L) speed leds are on at the same time.

BMS Function

BMS Function makes the unit to be monitored on a central automation system.

1. Dry contact outputs: There are 2 dry contact outputs. Working status and failure status of the unit can be monitored.

2. Dry contact input: Operation of the unit (on / off) can be done by dry contact input. When this function is active, you can't turn on / off the unit on control panel. To activate this function, turn “dip switch 4” on.

If there is no switch on the PCB, 98th parameter of service menu can be used to activate this function. (0 = Enable)

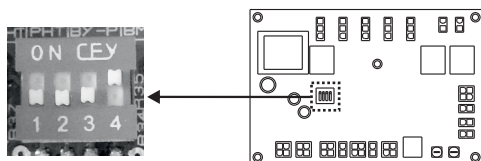

Modbus Function

Modbus function helps to monitor the unit and change all possible functions on a central automation system.

Weekly Timer Function

Weekly timer function is available on Pro Panel. Unit can be programmed to operate automatically on certain periods of the week. Three options are available:

1. 5+0 : Active for 5 weekdays, off on weekends
1. 5+1 : Active for 5 weekdays and on Saturday, off on Sunday
1. 5+2 : Active for all days of the week

Log Function

Log Function is available on Pro Panel. It records all the activity of the unit as date and hour.

Fire Function

There is a dry contact relay on the control board. The fire function is activated in case of on fire, if the dry contact relay is attached to fire system.

Note: In case of fire, the unit is closed on Basic Panel. Different scenarios can be selected on Pro Panel.

Warnings

There are three types of warnings on Basic Panel:

1. If red warning signal lights continuously, it means fan failure or outdoor air thermistor failure. (Unit is not working.)
2. If red warning signal and fan speed led lights simultaneously, it means failure of components. (Only fans are running.)
3. If red warning signal flashes, it is an alarm of dirty filter.

Screen failure code is "ERR" on Pro Panel. (See failure code list.)

Note: After troubleshooting, press  on Basic Panel and  on Pro Panel for 3 seconds.

Child Proof Protection Function

It is used to lock the keypad. (See use of keypad.)

Note: Child proof protection is available on Pro Panel. This function will be activated if any button isn't pressed for 10 seconds.

Sensor (VOD) (Optional)

Sensor (VOD) function is available on Pro Panel. It runs with CO₂ sensor, air quality sensor or humidity sensor. Speed of fans changes automatically according to the information coming from these sensors.

Basic Panel Control Functions



1. **ON/OFF:** Press  for 3 seconds.



2. Press  to increase fan speed.





3. Press  to decrease fan speed.





4. Press  to activate "boost" function.



5. **Single Fan Mode (OA):** If you press  for 3 seconds, RA fan will be off and OA fan will continue to run. At which step the fan is running, light of that fan speed starts to flash. To deactivate this mode, press  or  for 3 seconds.







6. **Single Fan Mode (RA):** If you press  for 3 seconds, OA fan will be off and RA fan will continue to run. At which step the fan is running, light of that fan speed starts to flash. To deactivate this mode, press  or  for 3 seconds.



7. To reset the duration of filter contamination depending time, press  and .



8. **Child Proof Protection:** To activate this function, press  and  for 3 seconds. When child proof protection is active, keypad is locked and buttons do not work. To deactivate this function press  and  for 3 seconds.

Pro Panel Control Functions



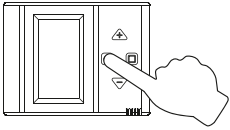

Please connect the Pro Panel when unit is off.

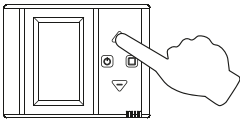

1. ON/OFF: Press  for 3 seconds.



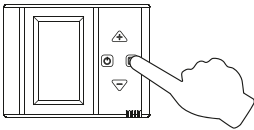

2. Press  or  to switch to screens in between.

- Press  to switch to next screen.
- Press  to switch to previous screen.



3. Press  to change any value on screen.

- Press  to increase existing value + 1
- Press  to decrease existing value - 1

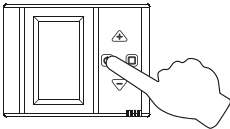

4. Press  to exit existing menu.

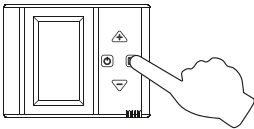

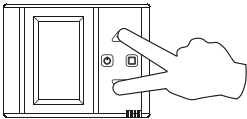

5. Press  to activate "boost" function.

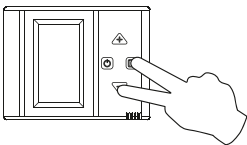

6. Child Lock : To activate this function, press  and  for 3 seconds. When child proof protection is active, keypad is locked and buttons do not work. To deactivate this function press  and  for 3 seconds.



7. To reset the duration of filter contamination depending time, press  and . Hold the buttons during reset time that appears on screen. When countdown is over, press .

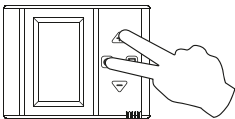

8. Press  and  simultaneously to adjust screen brightness and contrast.

Pro Panel Screen

1. Screen	2. Screen	3. Screen
Main Screen	Timer	Screen Brightness and Contrast Setting

1. Screen Symbols (Main Screen)

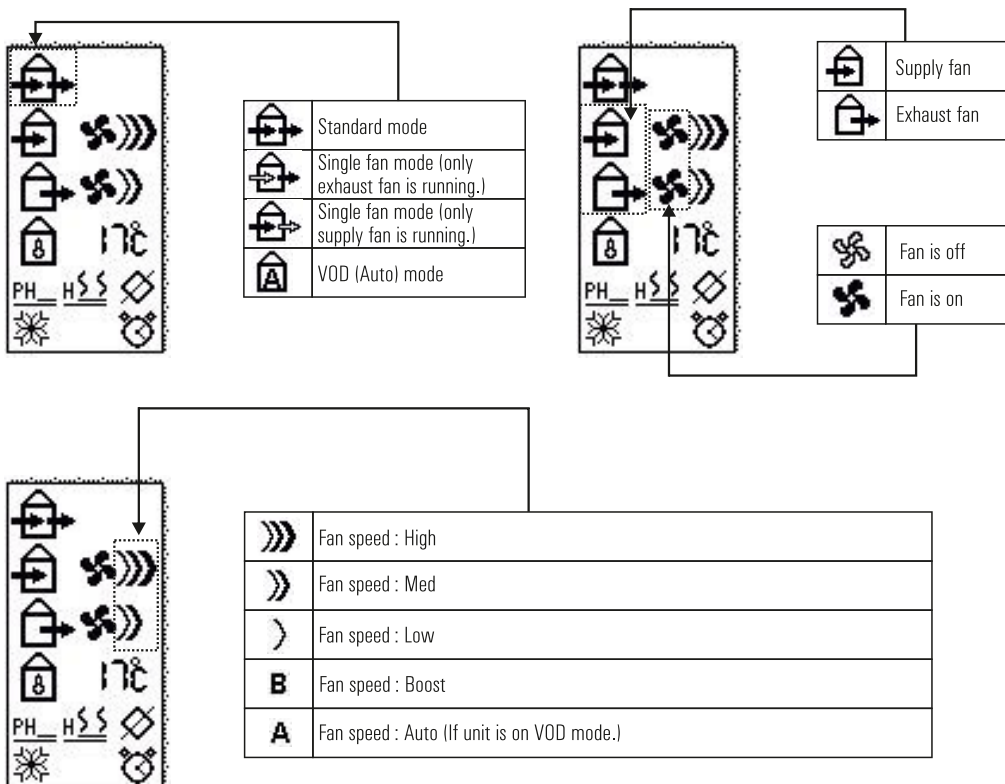

Pro Panel Screen

1. Screen Symbols (Main Screen)

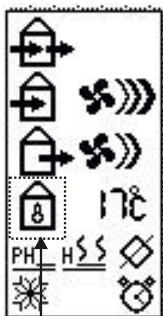

	Outdoor air temperature
	Indoor air temperature
	Set temperature

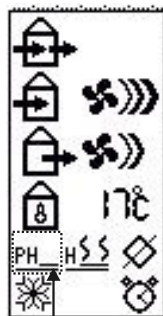

	There is no pre-heater.
	Pre-heater is off.
	Pre-heater is on.

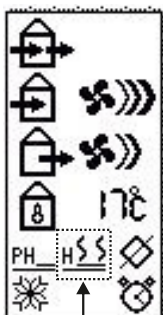

	There is no heater.
	Heater is off.
	Heater is on at first stage.
	Heater is on at first and second stage.
	There is water coil. It is off.
	Cooling coil is on.
	Heating coil is on.

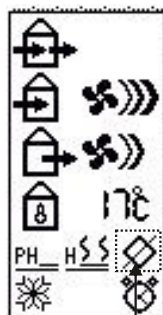

	There is no by-pass.
	By-pass is off.
	By-pass is on.

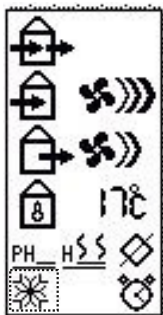

	No failure, freezing scenario is off.
	During a failure situation, the code "ERR" and its code will be seen on screen.
	Filter dirty
	Freezing scenario is on.

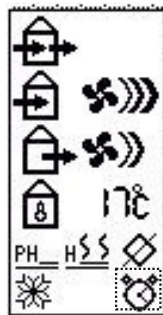

	BMS and TIMER is not adjusted.
	BMS is on.
	TIMER is on.

Pro Panel Screen

2. Screen Symbols (Timer)



Start-up time of unit

Shut down time of unit

Time hh.mm.ss

Date yy.mm.dd

---	TIMER is off
5+0	TIMER is on: 5 weekdays
5+1	TIMER is on: Weekdays + Saturdays
5+2	TIMER is on: All days

4. Screen Symbols (Screen Brightness and Contrast Setting)



Screen brightness value

Screen contrast value

Error Code List

Register 25 Value	Pro Panel Screen Code	Description
0	----	Unit is working normally.
1	ERR 1	Fire alarm
2	ERR 2	Heater alarm
3	ERR 3	Supply fan failure (OA)
4	ERR 4	Exhaust fan failure (RA)
5	ERR 5	Outdoor air temperature sensor failure (OA)
6	ERR 6	Return air temperature sensor failure (RA)
7	ERR 7	Pro Panel sensor failure (P)
8	ERR 8	Supply air temperature sensor failure (SA)
9	ERR 9	Sensor-1 failure
10	ERR 10	Sensor-2 failure
11	ERR 11*	Gas pressure fault
12	FILTER	Alarm of dirty filter
13	ERR 12*	Gas pressure fault (gas circuit get blocked)
14	ERR 13*	Reset option is active.
15	ERR 15**	Pro Panel communication error

Note: * This is only available for DX units.

**This is only available for Pro Panel.

Modbus Connection

1. Introduction

This document includes the protocol of Modbus communication that is used with AIRTECHNIC and AIRTECHNIC-DX control boards.

2. Properties

Control board uses Modbus RTU protocol via RS485 connection. The unit works as Slave and the information can be taken from an external Master module.

Connection information of the unit is listed as below:

Connection Type: **Modbus RTU Slave**

Standard Address: **1**

Link speed: **9.600**

Parity: **None**

Data Bits: **8**

Stop Bit: **1**

3. Physical Connection

Communication network is showed below. Control board can be connected to RS485 on which is connected more than one unit. Address conflicts on this line should be removed and necessary software settings should be done for data communication.

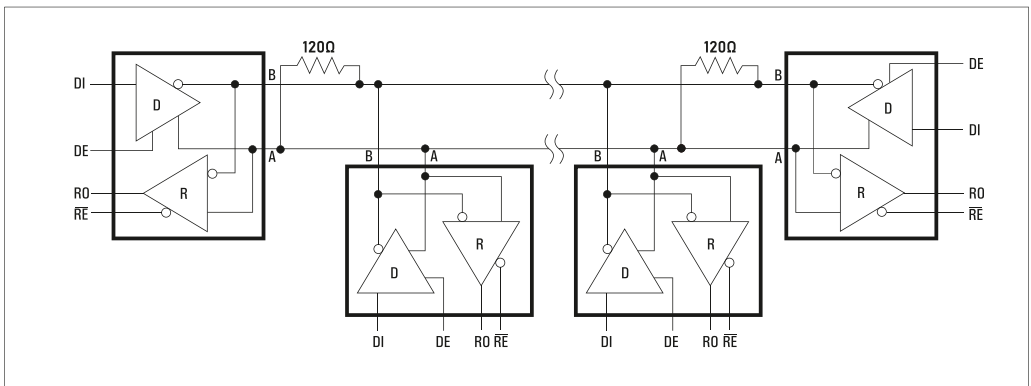

Fig. 2.1 RS485 Wiring Example

If the line is too long or if any communication problem occurs, 120 Ohm resistance should be added at the beginning and end of the line as shown on schema.

Modbus Connection

4. Modbus Functions

Communication package (Table 3.1) is the same for each function. First address information of relevant module is sent on package. After added information type, CRC code which is a failure code that evaluates accuracy of package is sent.

Table 3.1 Modbus package type

Address Information	Function Code	Data	Failure Control (CRC16)
---------------------	---------------	------	-------------------------

Control board supports only two of standard functions of Modbus. These codes are 03 register reading (Table 3.2) and 06 register writing (Table 3.3). In the example below (Table 3.2), master wants to know the 16 bit data on 2nd register. Corresponding response value of control board is shown on the table below. In the second example (Table 3.3), master wants to write the 16 bit data on 2nd register and it is reported to control board that the data was written.

Table 3.2 Function 03 Transfer Package Example

Master Transfer				
Address Information	Function Code	Register ID	Data Length	Failure Control
0 x 01	0 x 03	0 x 00 , 0 x 02	0 x 00 , 0 x 01	0 x 25 , 0 x CA

Response of Control Board				
Address Information	Function Code	Byte Length	Register ID	Failure Control
0 x 01	0 x 03	0 x 00	0 x 07 , 0 x FF	0 x FA , 0 x 34

Table 3.3 Function 06 Transfer Package Example

Master Transfer				
Address Information	Function Code	Register ID	Written Data	Failure Control
0 x 01	0 x 06	0 x 00 , 0 x 02	0 x 0C , 0 x 00	0 x 2D , 0 x 0A

Response of Control Board				
Address Information	Function Code	Register ID	Written Data	Failure Control
0 x 01	0 x 06	0 x 00 , 0 x 02	0 x 0C , 0 x 00	0 x 2D , 0 x 0A

Modbus Register List

ID	Name	Multiplier	Access	Unit	Limit	Valid	Explanation
0	Version of program	1	r	-	-	-	Version of installed program [MMYY]
1	Unit On / Off	1	rw	-	[0,1]	-	0-Stop,1-Start
6	Speed of supply fan	1	r	rpm	-	-	
7	Speed of exhaust fan	1	r	rpm	-	-	
11	Outdoor air temperature	0,1	r	°C	-	-	TerOA
12	Return air temperature	0,1	r	°C	-	-	TerRA
13	Supply air temperature	0,1	r	°C	-	-	TerSA
14	Pro panel temperature	0,1	rw	°C	[-40,80]	-	TerP
15	Sensor-1 input	0,01	r	%	-	-	-
16	Sensor-2 input	0,01	r	%	-	-	-
25	Alarm code	1	r	-	-	-	Failure Code
36	Rotor status	1	r	-	[0,1]	-	0-Off 1-On
37	By-pass status	1	r	-	[0,1]	-	0-Off 1-On
38	Pre-heater status	1	r	-	[0,1]	-	0-Off 1-On
39	After heater 1st stage status (Status of compressor for DX unit.)	1	r	-	[0,1]	-	0-Off 1-On
40	After heater 2nd stage status (Status of four-way for DX unit.)	1	r	-	[0,1]	-	0-Off 1-On
50	Mode selection	1	rw	-	[0,3]	0	0-Standard,1-Only exhaust fan,2-Only supply fan,3-VOD
51	Modbus address	1	rw	-	[1,254]	1	
52	Supply fan velocity stage	1	rw	-	[0,2]	0	0-low, 1-med, 2-high
53	Exhaust fan velocity stage	1	rw	-	[0,2]	0	0-low, 1-med, 2-high
56	Temperature set point	1	rw	°C	[18,28]	22	
**89	DX running mode	1	rw	-	[0,2]	0	0- Automatic, 1- Cooling, 2- Heating
101*	Pro-Panel modbus address	1	rw	-	[1,254]	1	

* PRO-Panel register values ** DX unit register values

Basic Panel Dimensions

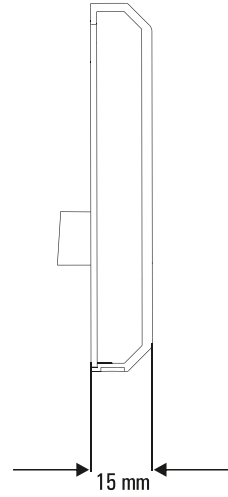
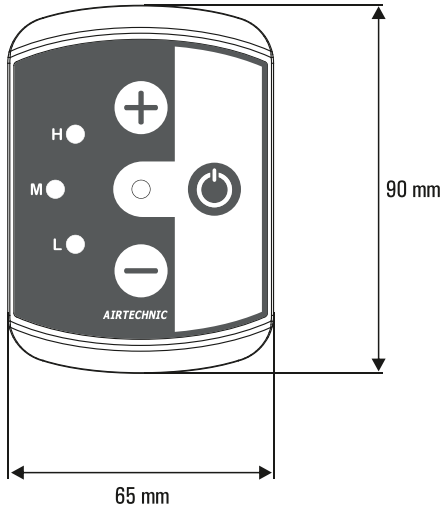

Pro Panel Dimensions

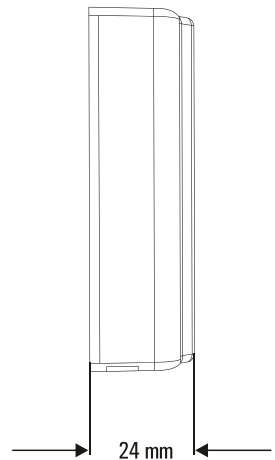
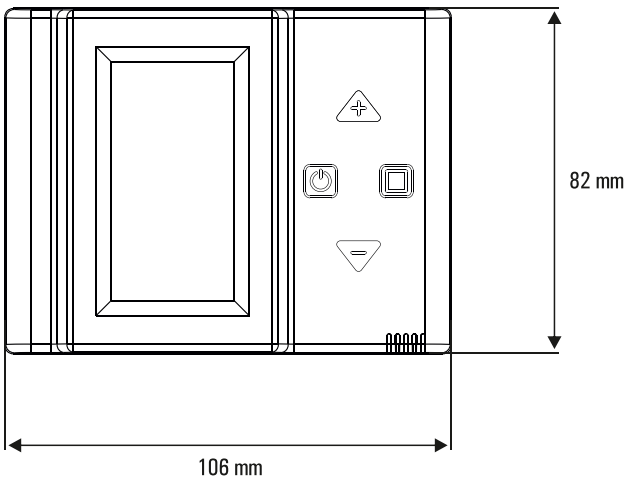

Basic Panel Installation

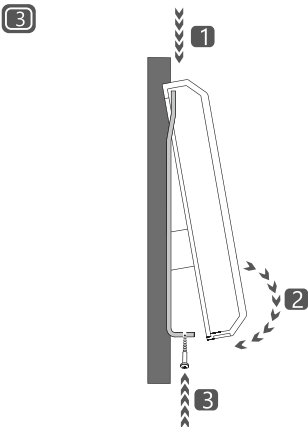
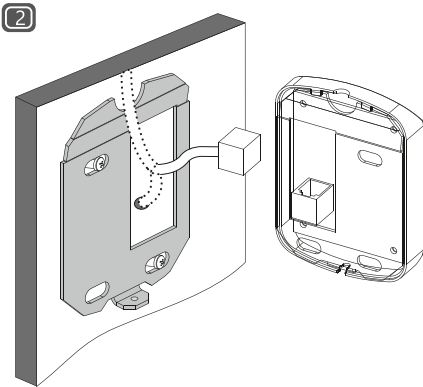
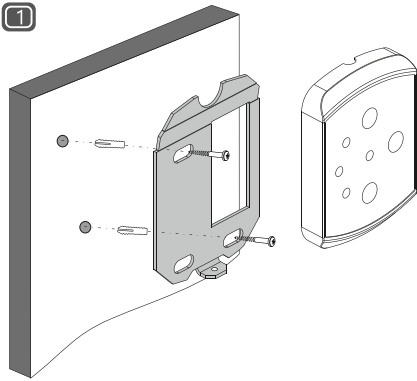

Pro Panel Installation

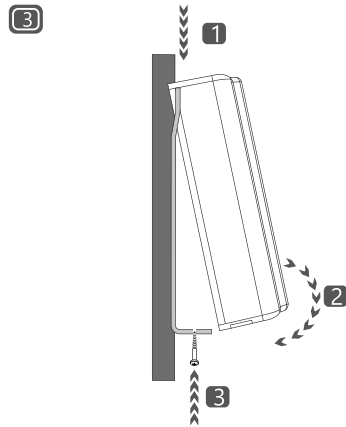
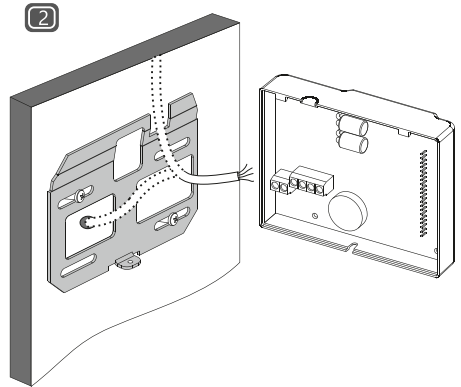
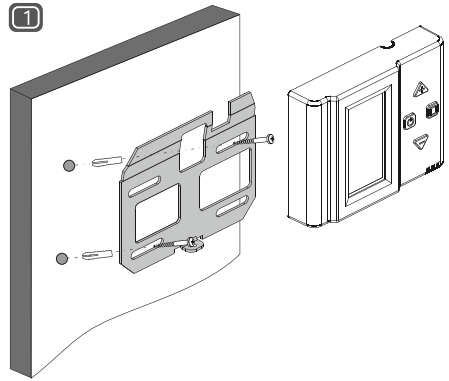

- ◆ TURN OFF all the power switches before the maintenance is performed.
- ◆ Do not operate the system without the air filter to protect the components of the unit against being clogged.
- ◆ Clean up the air filter more than once in a year.
- ◆ Clean up the heat exchanger more than once per year.

Heat Exchanger Cleaning

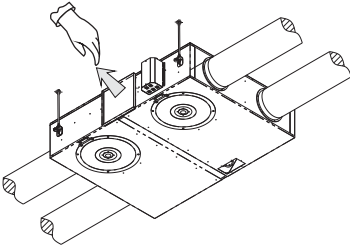

Step 1: Remove the exchanger's service cover, then remove the heat exchanger out from the main unit.

Note: The maximum weight of heat exchanger is 30 kg.

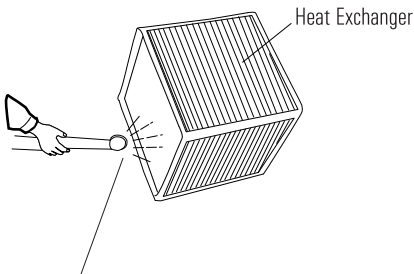

Clean using vacuum cleaner

Step 2: Cellulosic heat exchanger can be cleaned by using vacuum. Aluminium heat exchanger can be cleaned by hot water or steam. Leave to dry after cleaning heat exchanger. Connect the unit after making sure that the heat exchanger has dried.

Air Filter Cleaning

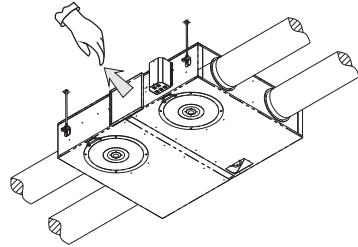

Step 1: Open the filter service cover. Remove the air filters from the unit.

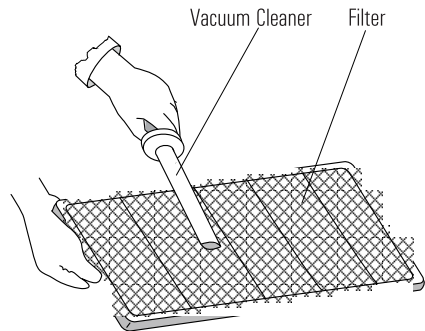

Step 2: Use a vacuum cleaner to suck up the dust from the air filter. If necessary, use warm water with addition a house detergent to remove the persistent dirt. Leave to dry after cleaning the air filter. Connect the unit after making sure that the filter has dried.



Management
System
ISO 9001:2015
Valid until:
30.06.2018
www.tuv.com
ID: 918602118

ISO 9001:2015

ISO 14001:2015

AIR HANDLING UNITS



**EUROVENT
CERTIFIED
PERFORMANCE**

www.airtechnic.gr
www.eurovent-certification.com

HEAT EXCHANGERS



**EC
MARK**

FAN COIL UNITS



FANS & FAN SECTIONS



FIRE DAMPERS

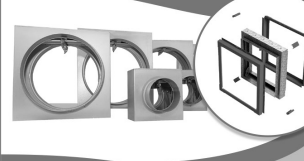

AIR OUTLETS

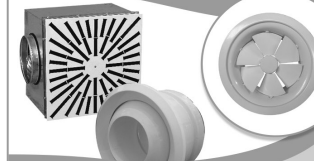

STEAM HUMIDIFIERS - DEHUMIDIFIERS



CENTRAL VACUUM SYSTEMS



**TUBO
THINK CLEAN**

STAINLESS STEEL CHIMNEYS



AIR FILTERS

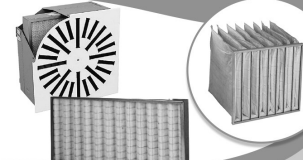

AIR CURTAINS

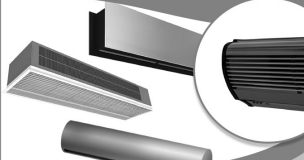

EVAPORATIVE COOLING



Main Office ATHENS

📍 Michail Karaoli Str. 19,
14343, Nea Chalkidona, Athens
211 - 705.55.00

✉ sales@airtechnic.gr

Factory - THIVA

📍 4th km Thiva - Chalkida Hwy,
32200, Thiva
22620 - 89.006

✉ factory@airtechnic.gr

Factory - THESSALONIKI

📍 End of Meandrou Str.,
57013, Oraiakastro, Thessaloniki
2311 - 82.40.00

✉ thessaloniki@airtechnic.gr