



# ENERGY BOX TUAS 4.000

Ceiling Type Energy / Heat / High Efficient Heat Recovery Units



ISO 9001:2015



ISO 14001:2015



|                                                  |         |
|--------------------------------------------------|---------|
| Index .....                                      | Page 1  |
| Warnings & Safety Informations.....              | Page 2  |
| Check List.....                                  | Page 3  |
| Technical Specifications.....                    | Page 4  |
| Unit Dimensions.....                             | Page 5  |
| Installation.....                                | Page 7  |
| Selection of Electrical Cable Cross-Section..... | Page 8  |
| Electrical Connection.....                       | Page 9  |
| Control System .....                             | Page 10 |
| Maintenance.....                                 | Page 26 |





## PROHIBITED

- ◆ This unit has to be used under proper conditions according to its technical specification and design purpose. (Otherwise responsibility belongs to practitioner)
- ◆ Unauthorized personnel must not interfere in unit and/or must not use unoriginal spare parts. (Otherwise responsibility of failure that may occur belongs to practitioner)
- ◆ Do not install this product in a refrigerated warehouse, heated swimming pool or other location where temperature and humidity are significantly different. (Failure to heed this warning may result in electrical shock or malfunctioning.)
- ◆ Do not install this product where it will be directly exposed to rain. (Failure to heed this warning may result in electrical shock or malfunctioning.)
- ◆ Do not install this product in a location where acid, alkali or organic solvent vapors, paints or other toxic gases, gases containing corrosive components or high concentrations of oily smoke are present (Failure to heed this warning may result not only in malfunctioning but also fire, power leakage and electrical shock.)
- ◆ Do not use this product outside the range of its rated voltage and control capacity.



## ATTENTION

- ◆ Install this product in an environment where the temperature ranges from -10 °C to +40 °C and the relative humidity is less than 60%. If condensation is expected to form, heat up the fresh outside air by a duct heater etc.
- ◆ Select an adequately sturdy position for installing the product and install it properly and securely.
- ◆ Use the designated electrical wires for the terminal board connections and connect the wires securely so that they will not be disconnected. (Failure to ensure proper connections may result in fire.)
- ◆ When passing metal ducts through wooden buildings clad with metal laths, wire laths or metal, these ducts must be installed in such a way that they will not make electrical contact with metal laths, wire laths or metal sheets. (Power leakage can cause ignition.)
- ◆ The outside ducts must be tilted at a gradient (1/30 or more) downwards toward the outdoor area from the main unit, and properly insulated. (The entry of rain water may cause power leaks, fire or damage to household property.)
- ◆ Gloves should be worn while installation. (Failure to heed this warning may result in injury.)
- ◆ A dedicated circuit breaker must be installed at the origin of mains power supply. This circuit breaker must be provided with a means for locking (lock and key).
- ◆ The body of the unit, room control panel and cables keep away the unit 3 m. distance



- ◆ This product must not be disassembled under any circumstances. Only authorized repair technicians are qualified to conduct disassembly and repairs. (Failure to heed this warning may result in fire, electrical shock or injury.)



- ◆ Connect the product properly to the ground. (Malfunctioning or power leaks can cause electrical shock.)



- ◆ An isolator switch having minimum contact gap of 3 mm in all poles must be provided as a means of disconnecting the power supply.

**NOTE:** The installations, which is not available for installation and operation manual, is out of guarantee.

In the event of unit failure and pre-commissioning checks to be made are determined as follows; after checking this information, please contact our company in case failure continues.

## Controls



Make sure that the unit receives power and electrical grounding is made!

Make sure that the electricity cables are drawn from in the correct cross section!  
(Please check whether there is heating on cables or not.)

Please check whether the cables in unit control panel are shielded (shielded magnetic field) or not; make sure shielding is grounded. If not, please change them!

Make sure that fresh air and exhaust air filters are clean and they do not block the flow of air!

Make sure there is the connection of drainage on the unit, check any possible clogging in drainage line and clean if necessary!

Please check whether the diameter of the air duct connection of the unit and the diameter of the spigot are the same. If the duct connection is smaller, change it with the correct one.

Make sure the electrical connections of the unit are made as suggested on the unit and in this guide, check if there is incorrect connection.

Make sure during the installation of the unit there is enough space for the service and if there is not enough space, re-install.

In extremely cold climate applications, frost may occur on the exchanger, apply electric heater in fresh air intake section of the unit to get the temperature to  $-8^{\circ}\text{C}$  and above.

After installing the unit, make sure that it does not create an abnormal sound or vibration, if there is, make sure that rubber pads are used.

|                                                                                |                   | ENERGY BOX<br>TUAS 4.000                 |
|--------------------------------------------------------------------------------|-------------------|------------------------------------------|
| Type of drive installed or intended to be installed                            |                   | variable speed drive                     |
| Type of HRS (run around, other, none)                                          |                   | other                                    |
| Thermal efficiency of heat recovery <sup>1</sup>                               | %                 | 75,8                                     |
| Nominal flow rate                                                              | m <sup>3</sup> /h | 2.750                                    |
| Maximum flow rate                                                              | m <sup>3</sup> /h | <b>4.000</b>                             |
| Effective electric power input                                                 | W                 | 1.100                                    |
| Face velocity at design flow rate                                              | m/s               | 1,9                                      |
| Nominal external pressure ( $\Delta P_{s,ext}$ ) <sup>1</sup>                  | Pa                | 100                                      |
| Internal pressure drop of ventilation components ( $\Delta P_{s,int}$ )        | Pa                | 200                                      |
| Internal pressure drop of non-ventilation components ( $\Delta P_{s,add}$ )    | Pa                | There is no "non-ventilation" components |
| Static efficiency of fans used in accordance with Regulation (EU) No. 327/2001 |                   | 59                                       |
| Declared maximum external leakage rate                                         | %                 | 0,6                                      |
| Declared maximum internal leakage rate                                         | %                 | 2,1                                      |
| Energy classification of the filters (Energy performance)                      |                   | G3                                       |
| Sound power level ( $L_{WA}$ ) (calculated) <sup>2</sup>                       |                   | 58                                       |

<sup>1</sup> Measured at balanced flow, EN 308.

<sup>2</sup> Sound power level values are valid for TUA units.

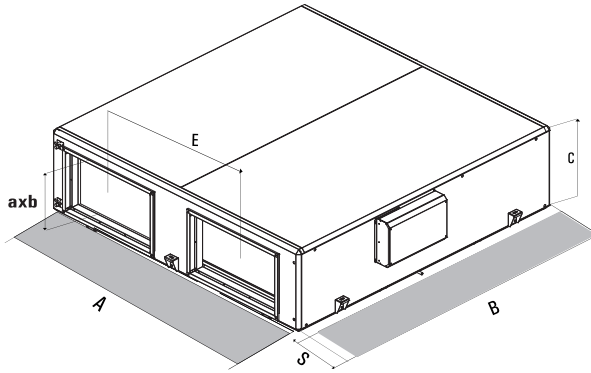

| ENERGY BOX<br>TUAS 4.000 | A     | B     | C   | a x b     | E     | S   | Unit Weight |
|--------------------------|-------|-------|-----|-----------|-------|-----|-------------|
|                          | 2.050 | 2.100 | 554 | 700 x 400 | 1.030 | 760 | 366         |

\* All measurement values are in "mm".

\* Unit weight is in "kg".

\* The gaps of the maintenance area values are specified as "S" on the table. ("Installation" is on page 6.)

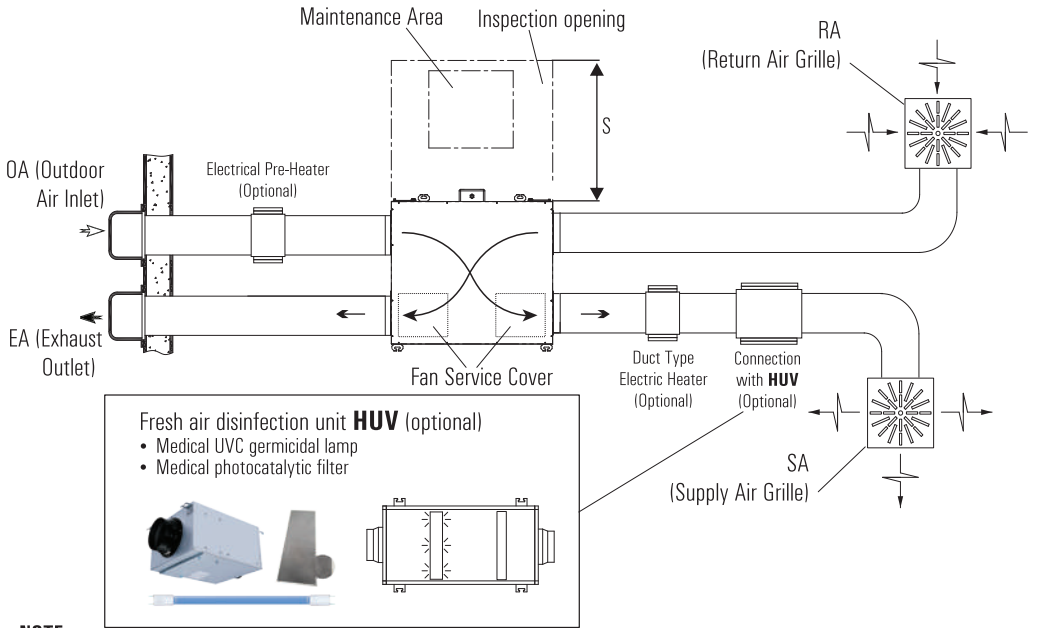

**NOTE:**

Top view : \*The gaps of the maintenance area are specified as "S" on the technical picture. ("Unit Dimension" is on pages 5, 6, 7)  
Fan access panels are under the unit. A service space of "C" must be left under the unit for fan service. (Please see "Unit Dimension" pages.)

Check these warnings before installation.

Extremely Sharp Bends



Multiple Bends



Bends right next to the outlet

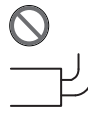

Extreme Reduction in the diameter of the connected ducts

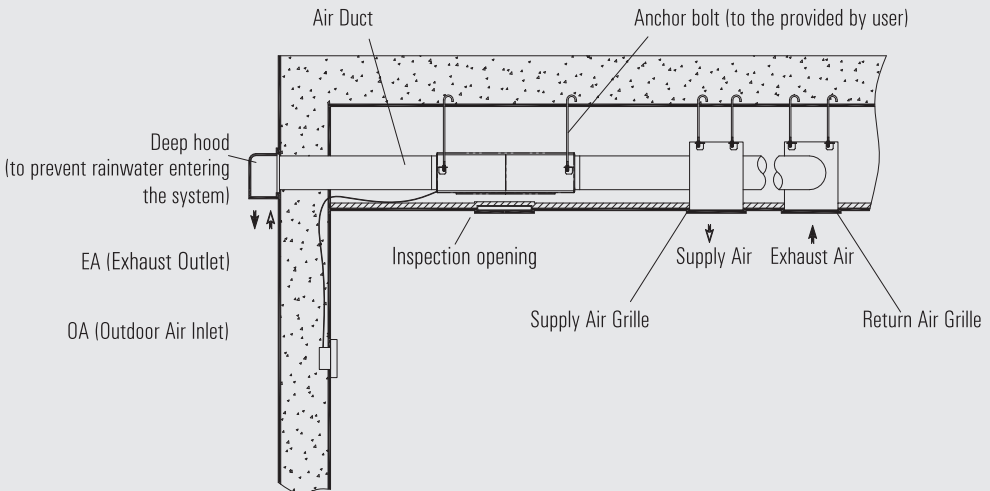
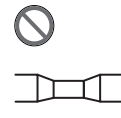

## Preparing The Sling Bolts

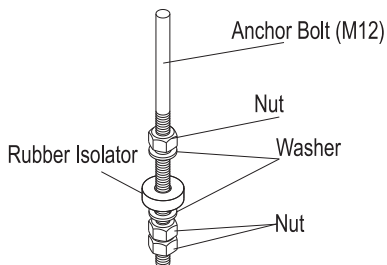

Hang the suspension bracket on the anchor bolts and adjust in such a way that the unit is installed horizontally. Tighten up securely using double nuts in order to prevent looseness.

### **! WARNING**

Check the stability of sling bolts during the installation.

## Installation of The Unit

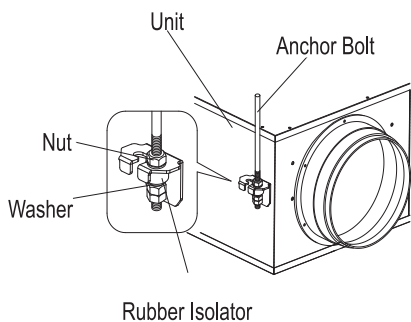

Hang the unit on the anchor bolts and adjust in such a way that the unit is installed horizontally. Tighten up securely using double nuts in order to prevent looseness.



| Unit Model               | Unit Voltage (V) | Unit Power Input (kW) | Current (A) | Fuse (A) | Cable Cross-Section (mm <sup>2</sup> ) for 50M and PF=0.8 |
|--------------------------|------------------|-----------------------|-------------|----------|-----------------------------------------------------------|
| ENERGY BOX<br>TUAS 4.000 | 380              | 2,2                   | 3,4         | 3 x 6    | 1,5                                                       |

## Cable Cross-Section Formulas

**1**

$$I_{\text{current}} = \frac{P}{U \times \text{Cos}\phi}$$

$$I_{\text{cable}} > I_{\text{current}}$$

**2**

$$\%e = \frac{100 \times P \times L}{k \times S \times U^2}, \quad S = \frac{100 \times P \times L}{k \times \%e \times U^2}$$

$$\%e = \%3$$

**3**

$$I_{\text{cable}} > I_{\text{fuse}} \geq I_{\text{current}}$$

$$\text{Cable Cross-Section } S = \text{Max}(S1, S2, S3, 1,5 \text{ mm}^2)$$

**P** : Power

**I** : Current

**U** : Voltage

**S** : Conductor cross section

**k** : Conductor coefficient

**L** : Conductor length

**%e**: The voltage drop

## Example of Cable Cross-Section Calculation

**P** : 1 kW                      **L** : 50 m  
**U** : 230V                      **%e**: %3  
**PF: Cosϕ** : 0,8              **k** : 56 m / Ω

**1**

$$I_{\text{current}} = \frac{1.000 \text{ W}}{230 \times 0,8} = 5,43 \text{ A}$$

The cable will be used, is selected from the cable cross-section table so that the equivalent ampere value in the table should be higher than calculated "I<sub>current</sub>" value.

$$S1 = 1,5 \text{ mm}^2$$

**2**

$$\%e = \%3$$

$$S = \frac{100 \times 1.000 \times 50}{56 \times 3 \times 230^2} = 0,56 \text{ mm}^2$$

$$S2 \geq 0,56 \text{ mm}^2 \geq 0,75 \text{ mm}^2$$

$$S2 = 0,75 \text{ mm}^2$$

**3**

$$I_{\text{cable}} > I_{\text{fuse}} \geq I_{\text{current}}$$

$$I_{\text{cable}} > 10A \geq 5,43A$$

"I<sub>fuse</sub>" which will be higher than "I<sub>current</sub>", is selected.

The cable will be used, is selected from the cable cross-section table so that the equivalent ampere value in the table should be higher than selected "I<sub>fuse</sub>" value.

$$I_{\text{cable}} = 24A$$

$$S3 = 1,5 \text{ mm}^2$$

$$\text{Cable cross-section } S = \text{Max}(S1, S2, S3, 1,5 \text{ mm}^2)$$

$$S = \text{Max}(1,5, 0,75, 1,5, 1,5)$$

$$S = 1,5 \text{ mm}^2$$

## RGS Control Panel Connector Diagram

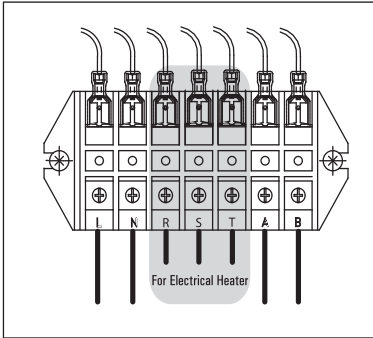

If RGS control panel is used for the models ENERGY BOX series, make the electrical connection with the connector in the switch box as shown in figure (L and N terminals)

Unit can be controlled by the control panel with connecting control panel's A and B terminals as shown. If these is an electric heater, the connectors which are tagged as R,S,T must be supplied by three-phase energy.

### **! WARNING**

Grid connection must be done to the L and N (R,S,T if necessary) terminals. A and B terminals are room control panel connections.

| Operation                        | Description                                                                                                                                                                                                                                                                                                                                                 | Basic Panel                            | Pro Panel                                               |
|----------------------------------|-------------------------------------------------------------------------------------------------------------------------------------------------------------------------------------------------------------------------------------------------------------------------------------------------------------------------------------------------------------|----------------------------------------|---------------------------------------------------------|
| Fan Speed Control                | 3 steps fan speed control of supply and exhaust fan is available.                                                                                                                                                                                                                                                                                           | 3 steps (2 fans)<br>(High / Med / Low) | 3 steps (each fans)<br>(High / Med / Low)               |
| Boost Function                   | <u>It is used for increasing fan speed:</u><br>Alternative-1: Via boost button on the control board<br>Alternative-2: Via dry contact or light power input (230V) (like kitchen light, bathroom light etc.) on PCB board.                                                                                                                                   | Standard                               | Standard                                                |
| Filter Function                  | <u>There are 2 alternatives to control filters:</u><br>Alternative-1: It records run time of the unit and when set time expires, control board gives an alert for filter change.<br>Alternative-2: Filter change time can be controlled with pressure switch mechanically. With this method, when filter needs to be changed control board gives an alert . | Standard<br><br>Optional               | Standard<br><br>Optional                                |
| By-Pass Function*                | Filtered fresh air is supplied indoor without passing in heat exchanger.                                                                                                                                                                                                                                                                                    | Optional                               | Optional                                                |
| Electric Heater Control Function | Electric heater is controlled up to 2 steps automatically according to the set temperature and indoor temperature.                                                                                                                                                                                                                                          | Optional<br>Depends on Return Air      | Optional<br>Depends on Return Air or Room or Supply air |
| Sensor (VOD)                     | Fans are running continuously in accordance with CO <sub>2</sub> sensor, air quality sensor or humidity sensor.                                                                                                                                                                                                                                             | -----                                  | Optional                                                |
| Frost Protection Function        | Where outdoor air is too low, this function is a protection method to prevent heat exchanger from freezing.                                                                                                                                                                                                                                                 | Standard                               | Standard                                                |
| Pre-Heater Function              | Where outdoor air is too low, fresh air is heated by a pre-heater before it enters into the unit. This function is a protection method to prevent heat exchanger from freezing.                                                                                                                                                                             | Optional                               | Optional                                                |
| External Control (BMS) Function  | IN: Unit can be on/off via control board.<br>OUT 1: Information of "unit status".<br>OUT 2: Information of "fault".                                                                                                                                                                                                                                         | Standard                               | Standard                                                |
| Modbus Function                  | It controls all functions of unit via PC or central automation board.                                                                                                                                                                                                                                                                                       | Standard                               | Standard                                                |
| Weekly Timer Function            | Unit can be programmed to operate on certain periods of the week.                                                                                                                                                                                                                                                                                           | -----                                  | Standard                                                |
| Log Function                     | All possible working options of the unit can be recorded.                                                                                                                                                                                                                                                                                                   | -----                                  | Standard                                                |
| Fire Function                    | It is used for changing working status of the unit in case of fire.                                                                                                                                                                                                                                                                                         | Standard                               | Standard                                                |
| Warnings                         | - Filter change<br>- Fan Fault<br>- Pre-Heater Fault<br>- Heater Fault                                                                                                                                                                                                                                                                                      | Standard (LED indicator)               | Standard (Display error code)                           |
| Child-Proof Protection Function  | It is used to lock the keypad.                                                                                                                                                                                                                                                                                                                              | Standard                               | Standard                                                |

**Note :** \* This function is standard in some units.

## Fan Speed Control Function:

Control board has 4 different fan speeds: "low", "medium", "high", "boost". These fan speeds are set to specific values by default. The maximum fan speed is "boost". If it is desired to change fan speeds, "low" and "high" set values can be changed by potentiometers on control board. If there is no potentiometer on the PCB, parameters of service menu can be used to change this function.

Control board automatically set the value of "medium" by averaging "high" and "low" values.

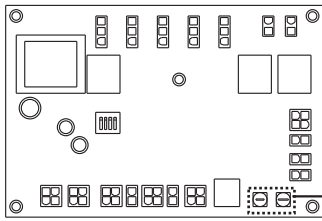

Potentiometer "High"



Potentiometer "Low"

### Service Parameter

- 26** Supply fan Low Speed Value
- 27** Supply fan Medium Speed Value
- 28** Supply fan High Speed Value
- 29** Extract fan Low Speed Value
- 30** Extract fan Medium Speed Value
- 31** Extract fan High Speed Value

**Note :** If "low" is set to the highest and "high" is set to the lowest value, unit continues to run according to default settings. Factory setting values can be changed by Pro Panel.

## Filter Function

This function controls filter change time. There are 2 alternatives to control filters:

1. It records run time of the unit. Filter change time is set a particular run time by factory settings. When set time expires, control board gives an alert (red warning light flashes) for filter change. After filter cleaning is done, filter setting time can be reset by pressing simultaneously and on Basic Panel, hold and during reset time that appears on screen. When countdown is over, press on Pro Panel.

**Note :** Default run time set value is changeable on Pro Panel.

2. Filter change time can be controlled by pressure switch mechanically. With this method, when filter needs to be changed, control board gives an alert (red warning light flashes). After changing/cleaning is completed, warning light goes off automatically.

## By-pass Function (Optional)

By-pass function only exists on units which have by-pass module. It is used when filtered fresh air is desired to be supplied to indoor without passing through heat exchanger (transition seasons). Control board decides whether by-pass module will be opened or not by controlling outdoor air temperature, return air temperature and set temperature values.

**Note :** To activate this function, turn "dip switch 3" on.

If there is no switch on the PCB, 97th parameter of service menu can be used to activate this function.(0 = Enable)

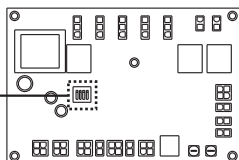

## Electric Heater Control Function (Optional)

Electric heater control function only exists on units which have duct type electric heater. This function controls electric heater that is used to increase temperature of supply air. It runs due to the return air temperature and set temperature values. 1 or 2 steps electric heater can be controlled.

**Note :** To activate this function, turn “dip switch 1” on.

If there is no switch on the PCB, 9th parameter of service menu can be used to activate this function. (0 = Enable)

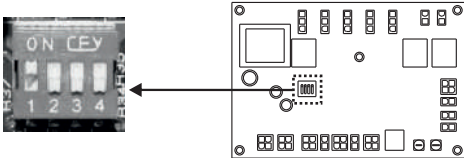

## Heating Coil Function (Optional)

This function is used in units which have duct type hot water coils. It controls the hot water coil which helps to increase supply air temperature and works due to set and return air temperature. It can control 230V on/off valve connected to water coil.

**Note :** To activate this function, following must be applied:

- Turn electric heater function on. (Turn dip switch 1 on)
- Make short cut in between HT\_Fault and HT\_P\_Fault inputs.
- Connect 230V on/off valve to 1.step electric heater control cable ends.

## Cooling Coil Function (Optional)

This function is used in units which have duct type cold water coils. It controls the cold water coil which helps to decrease supply air temperature and works due to set and return air temperature. It can control 230V on/off valve connected to water coil.

**Note :** To activate this function, following must be applied:

- Turn electric heater function on. (Turn dip switch 1 on)
- Activate “Cooling Coil” on unit settings. (This can be done by authorized technical service or default in factory)
- Make short cut in between HT\_Fault and HT\_P\_Fault inputs.
- Connect 230V on/off valve to 2.step electric heater control cable ends.

## Frost Protection Function

Condensation occurs inside the unit where outdoor air temperature is below 0°C. Heat exchanger can be damaged if condensation water freezes inside. Control board changes fan speed periodically to protect freezing.

**Note :** This function is active when outdoor air temperature is below -3°C. Set temperature value is changeable on Pro Panel.

## Pre-Heater Function (Optional)

This function helps to protect unit from freezing where outdoor air temperature is too low. It runs due to outdoor air temperature. 1 step electric heater can be controlled.

**Note 1 :** To activate this function, turn “dip switch 2” on.

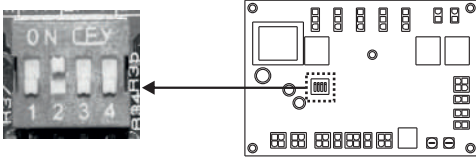

If there is no switch on the PCB, 95th parameter of service menu can be used to activate this function.(0= Enable)



**Note 2 :** This function is active when outdoor air temperature is below 0 °C. Set temperature value is changeable on Pro Panel.

## Boost Function

This function is used when large amount of exhaust and fresh air is needed (at the time of using kitchen/bathroom/wc, etc.) while ventilation is still going on. There are 2 boost functions on controller. One of them is on control panel, the other one is on control board:

1. “Boost” function is activated by pressing  on Basic Panel and  on Pro Panel for 3 seconds. After unit runs at boost speed (maximum speed) and during boost time (15 minutes) , it begins to run at the speed value that is set before boost function is activated.
2. There is one dry contact relay input and one 230V input on control board. If one of these inputs is activated, unit begins to run at “boost” speed. When activated input is passive again, unit begins to run at the speed value that is set before boost function is activated.

**Note 1 :** Boost speed and boost time are changeable on Pro Panel.

**Note 2 :** During operating at boost function on Basic Panel, “high” (H), “medium” (M) and “low” (L) speed leds are on at the same time.

## BMS Function

BMS Function makes the unit to be monitored on a central automation system.

1. Dry contact outputs: There are 2 dry contact outputs. Working status and failure status of the unit can be monitored.
2. Dry contact input: Operation of the unit (on / off) can be done by dry contact input. When this function is active, you can't turn on / off the unit on control panel. To activate this function, turn “dip switch 4” on.

If there is no switch on the PCB, 98th parameter of service menu can be used to activate this function.(0= Enable)

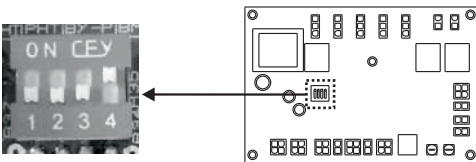

## Modbus Function

Modbus function helps to monitor the unit and change all possible functions on a central automation system.

## Weekly Timer Function

Weekly timer function is available on Pro Panel. Unit can be programmed to operate automatically on certain periods of the week. Three options are available:

1. 5 + 0 : Active for 5 weekdays, off on weekends
2. 5 + 1 : Active on 5 weekdays and saturday, off on sunday
3. 5 + 2 : Active for all days of the week

## Log Function

Log Function is available on Pro Panel. It records all the activity of the unit as date and hour.

## Fire Function

There is a dry contact relay on the control board. The fire function is activated in case of on fire, if the dry contact relay is attached to fire system.

**Note:** In case of fire, the unit is closed on Basic Panel. Different scenarios can be selected on Pro Panel.

## Warnings

There are three types of warnings on Basic Panel:

1. If red warning signal lights continuously, it means fan failure or outdoor air thermistor failure. (Unit is not working.)
2. If red warning signal and fan speed led lights simultaneously, it means failure of components. (Only fans are running.)
3. If red warning signal flashes, it is an alarm of dirty filter.

Screen failure code is "ERR" on Pro Panel. (See failure code list.)

**Note:** After troubleshooting, press  on Basic Panel and  on Pro Panel for 3 seconds.

## Child Proof Protection Function

It is used to lock the keypad. (See use of keypad.)

**Note :** Child proof protection is available on Pro Panel. This function will be activated if any button isn't pressed for 10 seconds.

## Sensor (VOD) (Optional)

Sensor (VOD) function is available on Pro Panel. It runs with CO<sub>2</sub> sensor, air quality sensor or humidity sensor. Speed of fans changes automatically according to the information coming from these sensors.

## Basic Panel Control Functions



1. ON / OFF: Press  for 3 seconds.



2. Press  to increase fan speed.





3. Press  to decrease fan speed.





4. Press  to activate "boost" function.



5. **Single Fan Mode (OA)** :If you press  for 3 seconds, RA fan will be off and OA fan will continue to run. At which step the fan is running, light of that fan speed starts to flash. To deactivate this mode, press  or  for 3 seconds.







6. **Single Fan Mode (RA)** :If you press  for 3 seconds, OA fan will be off and RA fan will continue to run. At which step the fan is running, light of that fan speed starts to flash. To deactivate this mode, press  or  for 3 seconds.



7. To reset the duration of filter contamination depending time, press  and .



8. **Child Proof Protection** :To activate this function, press  and  for 3 seconds. When child proof protection is active, keypad is locked and buttons do not work. To deactivate this function press  and  for 3 seconds.



## Pro Panel Control Functions



Please connect the Pro Panel when unit is off.

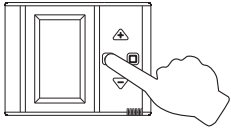

1. **ON / OFF:** Press  for 3 seconds.

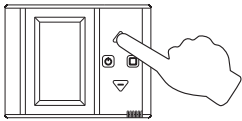

2. Press  or  to switch to screens in between.

- Press  to switch to next screen.

- Press  to switch to previous screen.

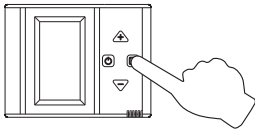

3. Press  to change any value on screen.

- Press  to increase existing value + 1

- Press  to decrease existing value - 1

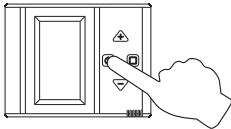

4. Press  to exit existing menu.

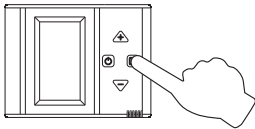

5. Press  to activate "boost" function.

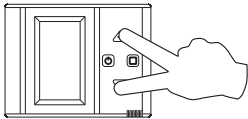

6. **Child Lock :** To activate this function, press  and  for 3 seconds. When child proof protection is active, keypad is locked and buttons do not work.

To deactivate this function press  and  for 3 seconds.

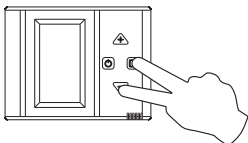

7. To reset the duration of filter contamination depending time, press  and .

Hold the buttons during reset time that appears on screen. When countdown is over, press .

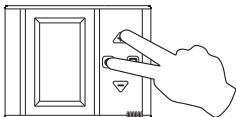

8. Press  and  simultaneously to adjust screen brightness and contrast.

## Pro Panel Screen

| 1. Screen   | 2. Screen | 3. Screen                              |
|-------------|-----------|----------------------------------------|
| Main Screen | Timer     | Screen Brightness and Contrast Setting |
|             |           |                                        |

### 1.Screen Symbols (Main Screen)

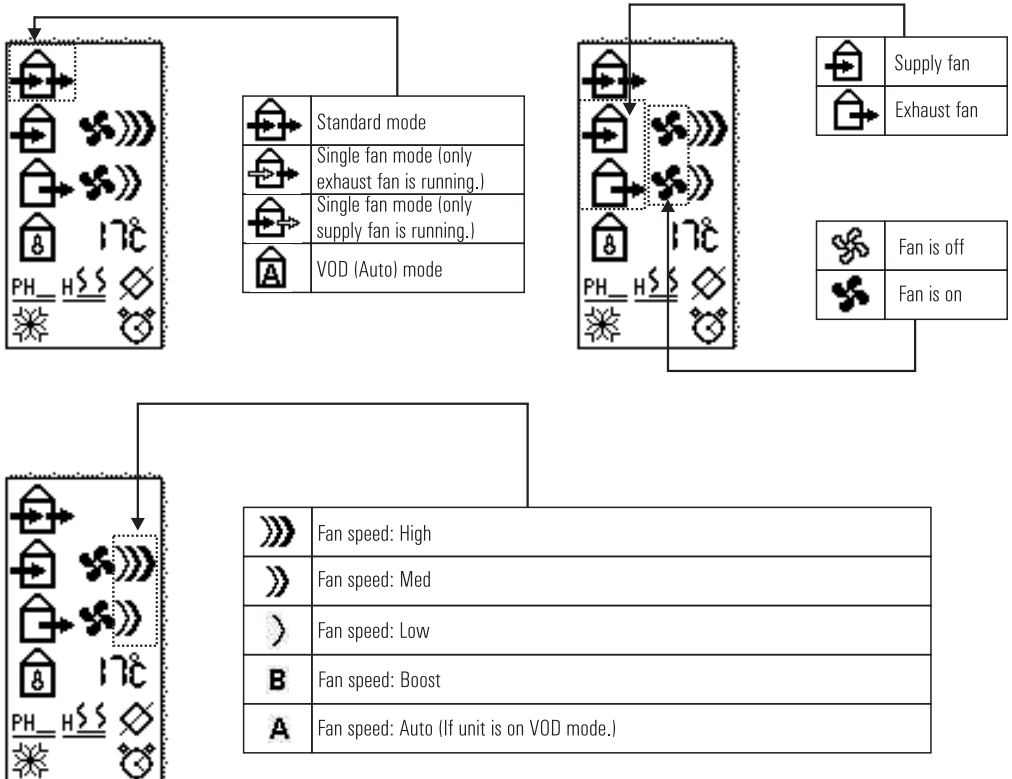

## Pro Panel Screen

### 1. Screen Symbols (Main Screen)

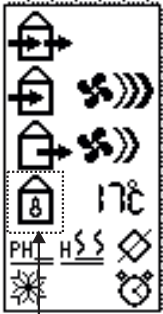

|  |                         |
|--|-------------------------|
|  | Outdoor air temperature |
|  | Indoor air temperature  |
|  | Set temperature         |



|             |                         |
|-------------|-------------------------|
|             | There is no pre-heater. |
| <u>PH</u>   | Pre-heater is off.      |
| <u>PHSS</u> | Pre-heater is on.       |

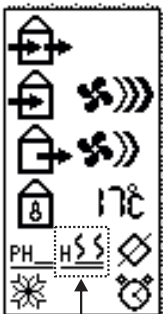

|             |                                         |
|-------------|-----------------------------------------|
|             | There is no heater.                     |
| <u>H</u>    | Heater is off.                          |
| <u>HSS</u>  | Heater is on at first stage.            |
| <u>HSSS</u> | Heater is on at first and second stage. |
| <u>CH</u>   | There is water coil. It is off.         |
| <u>CH*</u>  | Cooling coil is on.                     |
| <u>CHSS</u> | Heating coil is on.                     |



|  |                      |
|--|----------------------|
|  | There is no by-pass. |
|  | By-pass is off.      |
|  | By-pass is on.       |



|               |                                                                                 |
|---------------|---------------------------------------------------------------------------------|
|               | No failure, freezing scenario is off.                                           |
| <b>ERR</b>    | During a failure situation, the code "ERR" and its code will be seen on screen. |
| <b>FILTER</b> | Filter dirty                                                                    |
|               | Freezing scenario is on.                                                        |



|            |                                |
|------------|--------------------------------|
|            | BMS and TIMER is not adjusted. |
| <b>BMS</b> | BMS is on.                     |
|            | TIMER is on.                   |

## Pro Panel Screen

### 2. Screen Symbols (Timer)

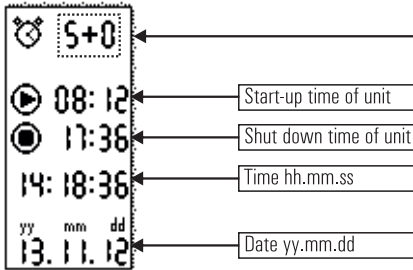

|     |                                  |
|-----|----------------------------------|
| --- | TIMER is off                     |
| 5+0 | TIMER is on: 5 weekdays          |
| 5+1 | TIMER is on: Weekdays+ Saturdays |
| 5+2 | TIMER is on: All days            |

### 3. Screen Symbols (Screen Brightness and Contrast Setting)

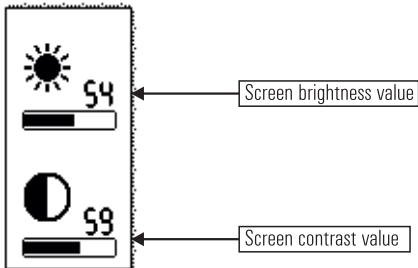

## Error Code List

| Register 25 Value | Pro Panel Screen Code | Description                                  |
|-------------------|-----------------------|----------------------------------------------|
| 0                 | ---                   | Unit is working normally.                    |
| 1                 | ERR 1                 | Fire alarm                                   |
| 2                 | ERR 2                 | Heater alarm                                 |
| 3                 | ERR 3                 | Supply fan failure (OA)                      |
| 4                 | ERR 4                 | Exhaust fan failure (RA)                     |
| 5                 | ERR 5                 | Outdoor air temperature sensor failure (OA)  |
| 6                 | ERR 6                 | Return air temperature sensor failure (RA)   |
| 7                 | ERR 7                 | Pro Panel sensor failure (P)                 |
| 8                 | ERR 8                 | Supply air temperature sensor failure (SA)   |
| 9                 | ERR 9                 | Sensor-1 failure                             |
| 10                | ERR 10                | Sensor-2 failure                             |
| 11                | ERR 11*               | Gas pressure fault                           |
| 12                | FILTER                | Alarm of dirty filter                        |
| 13                | ERR 12*               | Gas pressure fault (gas circuit get blocked) |
| 14                | ERR 13*               | Reset option is active.                      |
| 15                | ERR 15**              | Pro Panel communication error                |

**Note:** \* This is only available for DX units.

\*\*This is only available for Pro Panel.

## Modbus Connection

### 1. Introduction

This document includes the protocol of Modbus communication that is used with AIRTECHNIC and AIRTECHNIC-DX control boards.

### 2. Properties

Control board uses Modbus RTU protocol via RS485 connection. The unit works as Slave and the information can be taken from an external Master module.

Connection information of the unit is listed as below:

Connection Type : **Modbus RTU Slave**

Standard Address : **1**

Link speed : **9.600**

Parity : **None**

Data Bits : **8**

Stop Bit : **1**

### 3. Physical Connection

Communication network is showed below. Control board can be connected to RS485 on which is connected more than one unit. Address conflicts on this line should be removed and necessary software settings should be done for data communication.

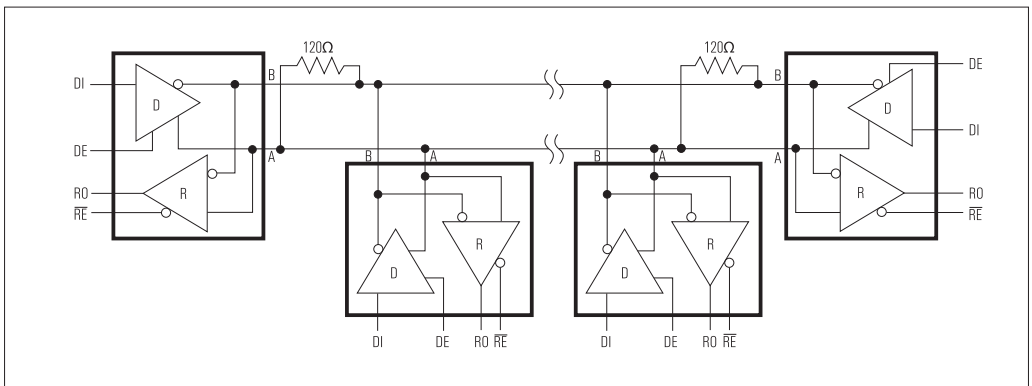

**Fig. 2.1 RS485 Wiring Example**

If the line is too long or if any communication problem occurs, 120 Ohm resistance should be added at the beginning and end of the line as shown on schema.

## Modbus Connection

### 4. Modbus Functions

Communication package (Table 3.1) is the same for each function. First address information of relevant module is sent on package. After added information type, CRC code which is a failure code that evaluates accuracy of package is sent.

**Table 3.1 Modbus package type**

|                     |               |      |                         |
|---------------------|---------------|------|-------------------------|
| Address Information | Function Code | Data | Failure Control (CRC16) |
|---------------------|---------------|------|-------------------------|

Control board supports only two of standard functions of Modbus. These codes are 03 register reading (Table 3.2) and 06 register writing (Table 3.3). In the example below (Table 3.2), master wants to know the 16 bit data on 2nd register. Corresponding response value of control board is shown on the table below. In the second example (Table 3.3), master wants to write the 16 bit data on 2nd register and it is reported to control board that the data was written.

**Table 3.2 Function 03 Transfer Package Example**

| Master Transfer     |               |                 |                 |                 |
|---------------------|---------------|-----------------|-----------------|-----------------|
| Address Information | Function Code | Register ID     | Data Length     | Failure Control |
| 0 x 01              | 0 x 03        | 0 x 00 , 0 x 02 | 0 x 00 , 0 x 01 | 0 x 25 , 0 x CA |

| Response of Control Board |               |             |                 |                 |
|---------------------------|---------------|-------------|-----------------|-----------------|
| Address Information       | Function Code | Byte Length | Register ID     | Failure Control |
| 0 x 01                    | 0 x 03        | 0 x 00      | 0 x 07 , 0 x FF | 0 x FA , 0 x 34 |

**Table 3.3 Function 06 Transfer Package Example**

| Master Transfer     |               |                 |                 |                 |
|---------------------|---------------|-----------------|-----------------|-----------------|
| Address Information | Function Code | Register ID     | Written Data    | Failure Control |
| 0 x 01              | 0 x 06        | 0 x 00 , 0 x 02 | 0 x 0C , 0 x 00 | 0 x 2D , 0 x 0A |

| Response of Control Board |               |                 |                 |                 |
|---------------------------|---------------|-----------------|-----------------|-----------------|
| Address Information       | Function Code | Register ID     | Written Data    | Failure Control |
| 0 x 01                    | 0 x 06        | 0 x 00 , 0 x 02 | 0 x 0C , 0 x 00 | 0 x 2D , 0 x 0A |

## Modbus Register List

| ID       | Name                                                                 | Multiplier | Access | Unit | Limit    | Valid | Explanation                                               |
|----------|----------------------------------------------------------------------|------------|--------|------|----------|-------|-----------------------------------------------------------|
| 0        | Version of program                                                   | 1          | r      | -    | -        | -     | Version of installed program [MMYY]                       |
| 1        | Unit On / Off                                                        | 1          | rw     | -    | [0,1]    | -     | 0-Stop,1-Start                                            |
| 6        | Speed of supply fan                                                  | 1          | r      | rpm  | -        | -     |                                                           |
| 7        | Speed of exhaust fan                                                 | 1          | r      | rpm  | -        | -     |                                                           |
| 11       | Outdoor air temperature                                              | 0,1        | r      | °C   | -        | -     | TerOA                                                     |
| 12       | Return air temperature                                               | 0,1        | r      | °C   | -        | -     | TerRA                                                     |
| 13       | Supply air temperature                                               | 0,1        | r      | °C   | -        | -     | TerSA                                                     |
| 14       | Pro panel temperature                                                | 0,1        | rw     | °C   | [-40,80] | -     | TerP                                                      |
| 15       | Sensor-1 input                                                       | 0.01       | r      | %    | -        | -     | -                                                         |
| 16       | Sensor-2 input                                                       | 0.01       | r      | %    | -        | -     | -                                                         |
| 25       | Alarm code                                                           | 1          | r      | -    | -        | -     | Failure Code                                              |
| 36       | Rotor status                                                         | 1          | r      | -    | [0,1]    | -     | 0-Off 1-On                                                |
| 37       | By-pass status                                                       | 1          | r      | -    | [0,1]    | -     | 0-Off 1-On                                                |
| 38       | Pre-heater status                                                    | 1          | r      | -    | [0,1]    | -     | 0-Off 1-On                                                |
| 39       | After heater 1st stage status<br>(Status of compressor for DX unit.) | 1          | r      | -    | [0,1]    | -     | 0-Off 1-On                                                |
| 40       | After heater 2nd stage status<br>(Status of four-way for DX unit.)   | 1          | r      | -    | [0,1]    | -     | 0-Off 1-On                                                |
| 50       | Mode selection                                                       | 1          | rw     | -    | [0,3]    | 0     | 0-Standard,1-Only exhaust fan,2-Only supply fan,<br>3-VOD |
| 51       | Modbus address                                                       | 1          | rw     | -    | [1,254]  | 1     |                                                           |
| 52       | Supply fan velocity stage                                            | 1          | rw     | -    | [0,2]    | 0     | 0-low, 1-med, 2-high                                      |
| 53       | Exhaust fan velocity stage                                           | 1          | rw     | -    | [0,2]    | 0     | 0-low, 1-med, 2-high                                      |
| 56       | Temperature set point                                                | 1          | rw     | °C   | [18,28]  | 22    |                                                           |
| **<br>89 | DX running mode                                                      | 1          | rw     | -    | [0,2]    | 0     | 0- Automatic, 1- Cooling, 2- Heating                      |
| 101*     | Pro-Panel modbus address                                             | 1          | rw     | -    | [1,254]  | 1     |                                                           |

\* PRO-Panel register values      \*\* DX unit register values



## Basic Panel Dimensions

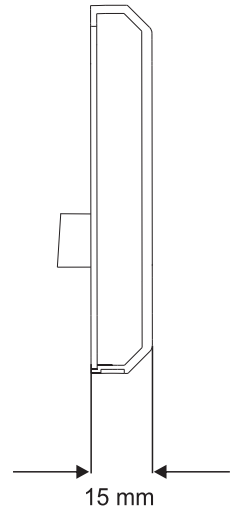
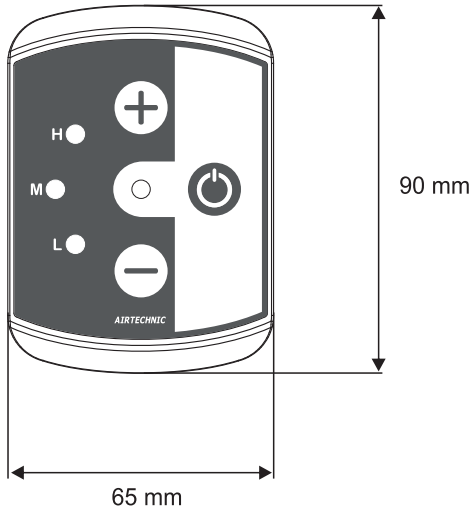

## Pro Panel Dimensions

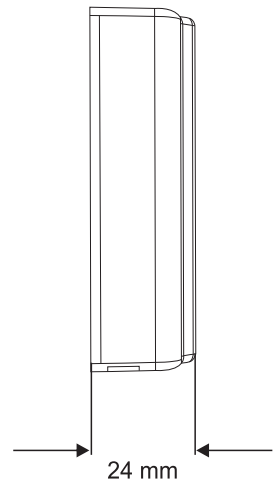
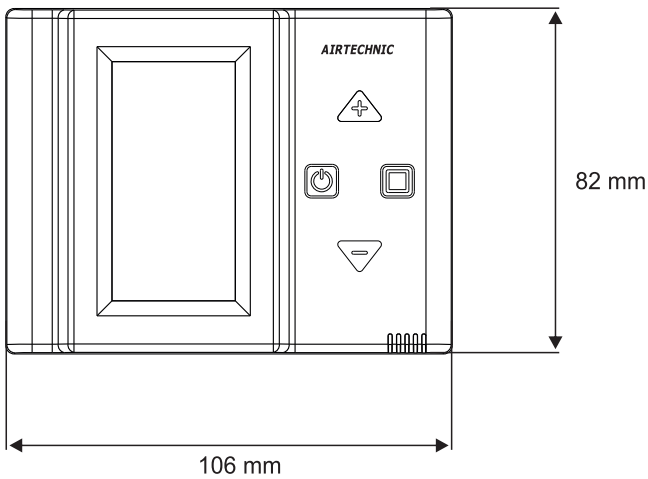

## Basic Panel Installation

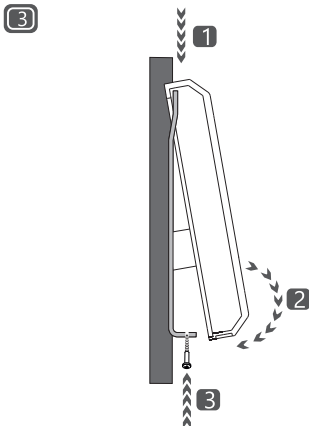
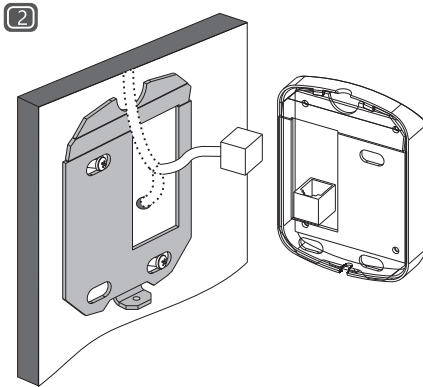
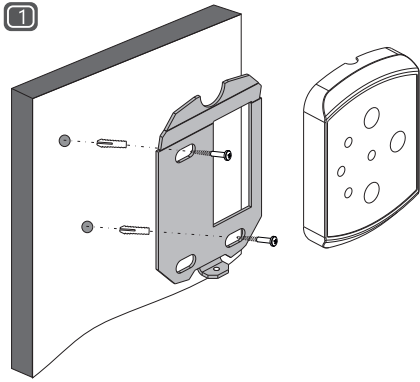

## Pro Panel Installation

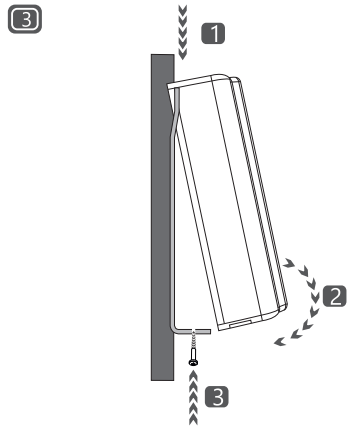
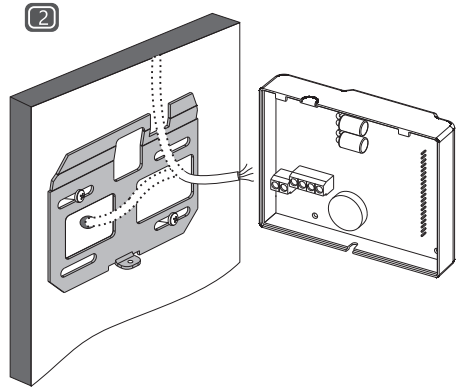
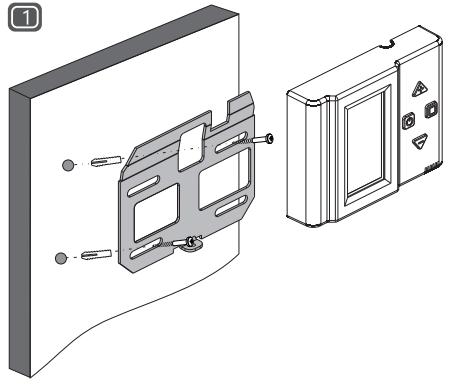

- ◆ TURN OFF all the power switches before the maintenance is performed.
- ◆ Do not operate the system without the air filter to protect the components of the unit against being clogged.
- ◆ Clean up the air filter more than once in a year.
- ◆ Clean up the heat exchanger more than once per year.

## Heat Exchanger Cleaning

**Step 1:** Before remove the exchanger's service cover, remove the drain connection.

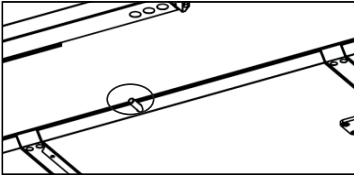

**Step 2:** Remove the exchanger's service panel, then remove the heat exchanger out from the main unit.

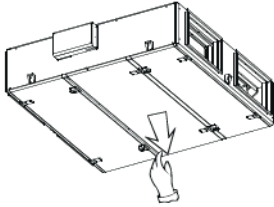

**Note:** The maximum weight of heat exchanger is 11 kg.

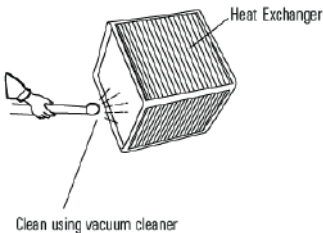

**Step 3:** Cellulosic heat exchanger can be cleaned by using vacuum. Aluminium heat exchanger can be cleaned by hot water or steam. Leave to dry after cleaning heat exchanger. Connect the unit after making sure that the heat exchanger has dried.

## Air Filter Cleaning

**Step 1:** Open the filter service panel.

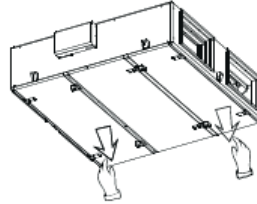

**Step 2:** Remove the filter lock mechanism as shown. Remove the air filters from the unit.

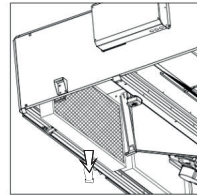
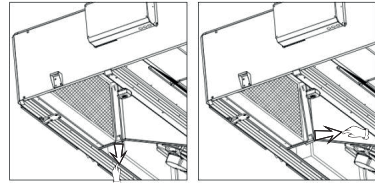

**Step 3:** Use a vacuum cleaner to suck up the dust from the air filter. If necessary, use warm water with addition a house detergent to remove the persistent dirt. Leave to dry after cleaning the air filter. Connect the unit after making sure that the filter has dried.

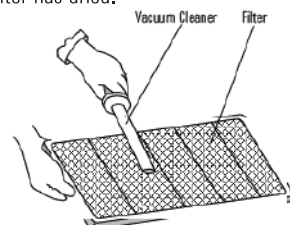

## Fan Service

---

**Step 1:** Open the fan service panel to remove the fan.

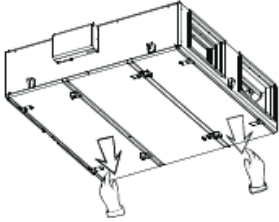

## Heater Coil Service (Optional)

---

**Step 1:** Open the heater coil service panel to remove the heater coil.

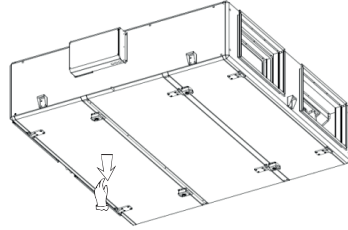

**Step 2:** Remove fan, then remove heater coil out of the unit.

**Note:** If the optional heater coil is purchased with the unit, the supply temperature sensor must be installed in the duct.







*Air-Conditioning & Ventilation Components & Systems*



**MAIN OFFICE ATHENS**

211 - 7055500  
sales@airtechnic.gr

**FACTORY THIVA**

4th km Thiva - Chalkida Hwy,  
32 200, Thiva  
Tel: 22620 - 89.006  
factory@airtechnic.gr

**FACTORY THESSALONIKI**

End of Meandrou Str.,  
570 13, Oraiakastro, Thessaloniki  
Tel: 2311 - 82.4000  
thessaloniki@airtechnic.gr