

USER'S MANUAL

VUT 300 HB(E) EC
VUT 400 HB(E) EC
VUT 700 HB(E) EC

VUE 300 HB(E) EC
VUE 400 HB(E) EC
VUE 700 HB(E) EC



Heat recovery air handling unit

CONTENTS

Safety requirements.....	2
Purpose.....	4
Delivery set.....	4
Designation key.....	4
Technical data.....	5
Unit design and operating principle.....	6
Installation and set-up.....	9
Connection to power mains.....	11
Unit control.....	13
Technical maintenance.....	13
Troubleshooting.....	15
Storage and transportation regulations.....	15
Manufacturer's warranty.....	16
Certificate of acceptance.....	17
Seller information.....	17
Installation certificate.....	17
Warranty card.....	17

This user's manual is a main operating document intended for technical, maintenance, and operating staff.

The manual contains information about purpose, technical details, operating principle, design, and installation of the VUT/VUE HB(E) EC unit and all its modifications.

Technical and maintenance staff must have theoretical and practical training in the field of ventilation systems and should be able to work in accordance with workplace safety rules as well as construction norms and standards applicable in the territory of the country.

The information in this user's manual is correct at the time of the document's preparation.

The Company reserves the right to modify the technical characteristics, design, or configuration of its products at any time in order to incorporate the latest technological developments.

No part of this publication may be reproduced, stored in a retrieval system, or transmitted, in any form or by any means in any information search system or translated into any language in any form without the prior written permission of the Company.

SAFETY REQUIREMENTS

- Please read the user's manual carefully prior to installing and operating the unit.
- All user's manual requirements as well as the provisions of all the applicable local and national construction, electrical, and technical norms and standards must be observed when installing and operating the unit.
- The warnings contained in the user's manual must be considered most seriously since they contain vital personal safety information.
- Failure to follow the rules and safety precautions noted in this user's manual may result in an injury or unit damage.
- After a careful reading of the manual, keep it for the entire service life of the unit.
- While transferring the unit control, the user's manual must be turned over to the receiving operator.

UNIT INSTALLATION AND OPERATION SAFETY PRECAUTIONS



- Disconnect the unit from power mains prior to any installation operations.



- Unpack the unit with care.



- The unit must be grounded!



- While installing the unit, follow the safety regulations specific to the use of electric tools.



- Do not change the power cable length at your own discretion. Do not bend the power cable. Avoid damaging the power cable. Do not put any foreign objects on the power cable.

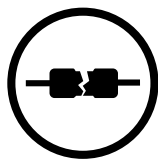

- Do not use damaged equipment or cables when connecting the unit to power mains.



- Do not touch the unit controls with wet hands. Do not carry out the installation and maintenance operations with wet hands.



- Do not allow children to operate the unit.



- Do not store any explosive or highly flammable substances in close proximity to the unit.

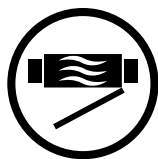

- Do not open the unit during operation.



- Do not block the air duct when the unit is switched on.

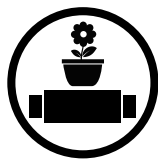

- Do not sit on the unit and avoid placing foreign objects on it.



- Do not lay the power cable of the unit in close proximity to heating equipment.

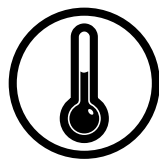

- Do not operate the unit outside the temperature range stated in the user's manual. Do not operate the unit in aggressive or explosive environments.

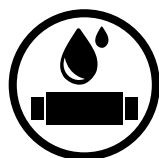

- Do not wash the unit with water. Protect the electric parts of the unit against ingress of water.

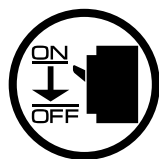

- Disconnect the unit from power mains prior to any technical maintenance.



- When the unit generates unusual sounds, odour, or emits smoke, disconnect it from power supply and contact the Seller.



- Do not direct the air flow produced by the unit towards open flame or ignition sources.



- In case of continuous operation of the unit, periodically check the security of mounting.



- Use the unit only for its intended purpose.



**THE PRODUCT MUST BE DISPOSED SEPARATELY AT THE END OF ITS SERVICE LIFE.
DO NOT DISPOSE THE UNIT AS UNSORTED DOMESTIC WASTE.**

PURPOSE



THE UNIT SHOULD NOT BE OPERATED BY CHILDREN OR PERSONS WITH REDUCED PHYSICAL, MENTAL, OR SENSORY CAPACITIES, OR THOSE WITHOUT THE APPROPRIATE TRAINING.

THE UNIT MUST BE INSTALLED AND CONNECTED ONLY BY PROPERLY QUALIFIED PERSONNEL AFTER THE APPROPRIATE BRIEFING.

THE CHOICE OF UNIT INSTALLATION LOCATION MUST PREVENT UNAUTHORIZED ACCESS BY UNATTENDED CHILDREN.

The unit is designed to ensure continuous mechanical air exchange in houses, offices, hotels, cafés, conference halls, and other utility and public spaces as well as to recover the heat energy contained in the air extracted from the premises to warm up the filtered stream of supply air.

The unit is not intended for organizing ventilation in swimming pools, saunas, greenhouses, summer gardens, and other spaces with high humidity.

Due to the ability to save heating energy by means of energy recovery, the unit is an important element of energy-efficient premises.

The unit is a component part and is not designed for stand-alone operation.

It is rated for continuous operation.

Transported air must not contain any flammable or explosive mixtures, evaporation of chemicals, sticky substances, fibrous materials, coarse dust, soot and oil particles or environments favourable for the formation of hazardous substances (toxic substances, dust, pathogenic germs).

Relative humidity of transported air must not exceed 80 % at an ambient temperature of +20 °C.

DELIVERY SET

NAME	NUMBER
Air handling unit	1 pc.
Control panel	1 pc.
User's manual	1 pc.
Packing box	1 pc.

DESIGNATION KEY

Designation example: **VUT 300 HBE EC A21**

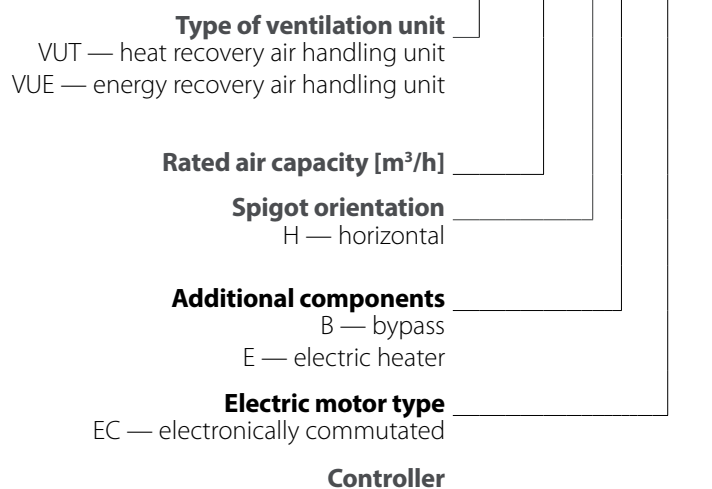

TECHNICAL DATA

The unit is designed for indoor application with the ambient temperature ranging from +1 °C up to +40 °C and relative humidity up to 80 %. In order to prevent condensation on the internal walls of the units, it is necessary that the surface temperature of the casing is 2-3 °C higher than the dew point temperature of the transported air.

The unit is rated as a Class I electrical appliance.

Hazardous parts access and water ingress protection rating:

- IP22 for the unit connected to the air ducts
- IP44 for the unit motors

The unit design is constantly being improved, thus some models may be slightly different from those described in this manual.

Parameters	VUT 300 HBE EC		VUE 300 HBE EC		VUT 400 HBE EC		VUE 400 HBE EC		VUT 700 HBE EC		VUE 700 HBE EC	
Unit voltage [V/50 (60) Hz]	1~ 230											
Maximum unit power [W]	182		182		289		289		336		336	
Maximum unit current (without an electric heater) [A]	1.4		1.4		2.1		2.1		2.4		2.4	
Electric heater power [W]	-	2800	-	2800	-	2800	-	2800	-	3600	-	3600
Electric heater current [A]	-	12.2	-	12.2	-	12.2	-	12.2	-	15.6	-	15.6
Maximum unit power (with an electric heater) [W]	182	2982	182	2982	289	3089	289	3089	336	3936	336	3936
Maximum unit current (with an electric heater) [A]	1.4	13.6	1.4	13.6	2.1	14.3	2.1	14.3	2.4	18.0	2.4	18.0
Maximum air flow [m ³ /h]	380		380		540		540		830		830	
RPM [min ⁻¹]	2100		2100		2600		2600		3200		3200	
Sound pressure level at a distance of 3 m [dBA]	24		24		27		27		31		31	
Transported air temperature [°C]	-25...+40											
Casing material	Aluzinc											
Insulation	40 mm mineral wool											
Extract air filter	G4											
Supply filter	G4+F7											
Connected air duct diameter [mm]	Ø 160		Ø 160		Ø 200		Ø 200		Ø 250		Ø 250	
Weight [kg]	63.1	64.3	63.1	64.3	74.8	76	74.8	76	107	108.4	107	108.4
Heat recovery efficiency [%]	80-98		74-89		84-98		78-89		80-98		74-89	
Heat exchanger type	Counter-flow											
Heat exchanger material	Polystyrene		Enthalpy		Polystyrene		Enthalpy		Polystyrene		Enthalpy	
SEC class	A+	A+	A	A	A+	A+	A	A	A+	A+	A	A

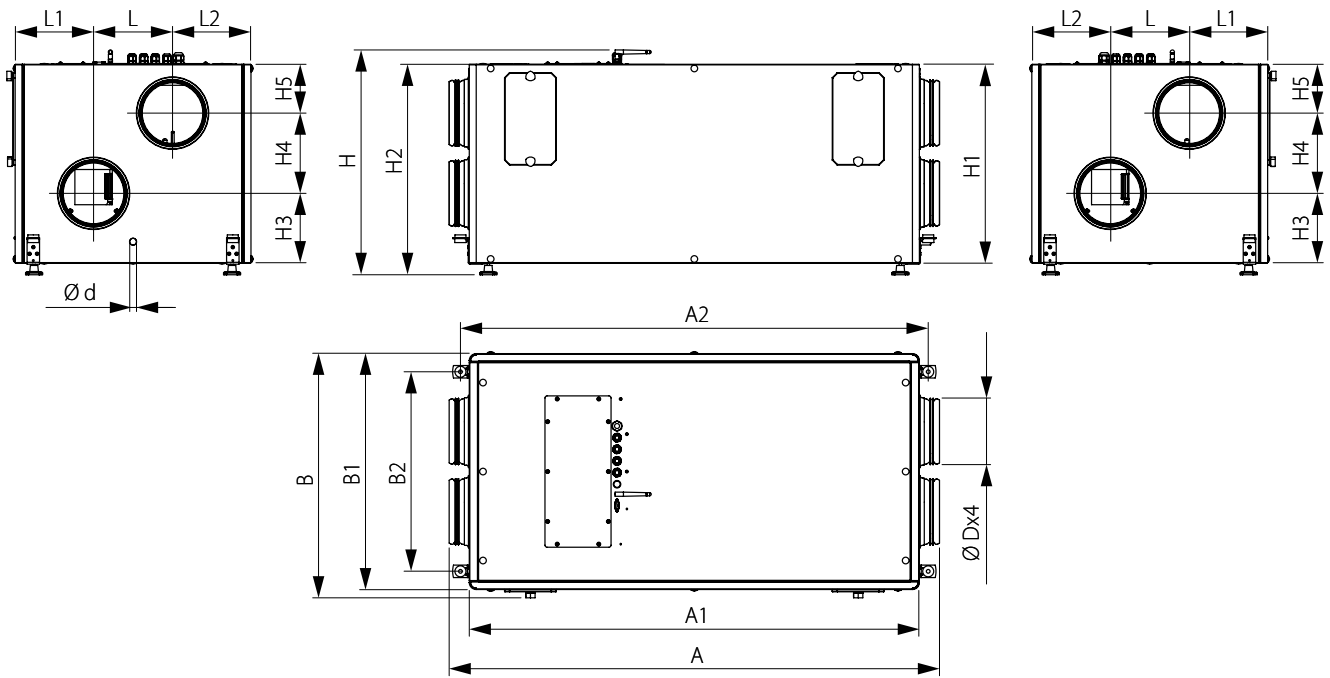

Model	Overall and connecting dimensions [mm]																
	d	D	A	A1	A2	B	B1	B2	H	H1	H2	H3	H4	H5	L	L1	L2
VUT/VUE 300 HB(E) EC	16	157	1180	1083	1126	586	566	480	540	479	506	168	193	118	190	189	189
VUT/VUE 400 HB(E) EC	16	197	1191	1094	1137	702	682	596	566	504	531	162	201	141	248	217	217
VUT/VUE 700 HB(E) EC	16	247	1379	1282	1325	886	866	700	663	601	629	201	234	166	274	296	296

CAUTION! Technical data and dimensions of the control panel (included in the delivery set) are specified in the user's manual of the panel.

UNIT DESIGN AND OPERATING PRINCIPLE

Warm stale extract air from the room flows to the unit, where it is filtered by the extract filter, then air flows through the heat exchanger and is exhausted outside by the extract fan. Cold fresh air from outside flows into the unit, where it is cleaned by the supply filter. Then filtered air flows through the heat exchanger and is moved to the room with the supply fan.

Thermal energy of warm extract air is transferred to clean intake fresh air from outside and warms it up. The air flows are fully separated. Heat recovery minimizes heat losses, which reduces the cost of space heating in the cold season.

- The removable service plates for filter replacement are located on the service side of the unit. Service side change is available.
- The VUT/VUE HBE A21 models are equipped with a built-in reheater for heating the supply air to a more comfortable temperature. An NKD electric duct heater can be optionally connected to the VUT/VUE HB A21 units. The heaters operate automatically according to the temperature sensor readings. The NKD heater must be installed in the supply air duct downstream of the heat exchanger.
- Heat exchanger freeze protection in units with an A21 controller is carried out:
 - By means of an automatic cyclic shut-off of the supply fan, with the extract fan running.
 - By means of the bypass duct with a bypass damper, which automatically opens the bypass duct upon the temperature sensor readings. When the bypass damper is opened, the extract air that is removed from the premises bypasses the heat exchanger.
 - With an NKP preheater (purchased separately). Switching the NKP heater on/off is carried out automatically upon the temperature sensor readings. The heater must be installed in the supply air duct upstream of the heat exchanger.
 The choice of the required heat exchanger freeze protection is made in the mobile application.
- Heat exchanger freeze protection in units with an A14 controller is carried out by means of automatic shut-off of the supply fan, with the extract fan running.
- Changing the position of the damper (opening/closing) in units with an A14 controller is done manually on the control panel.

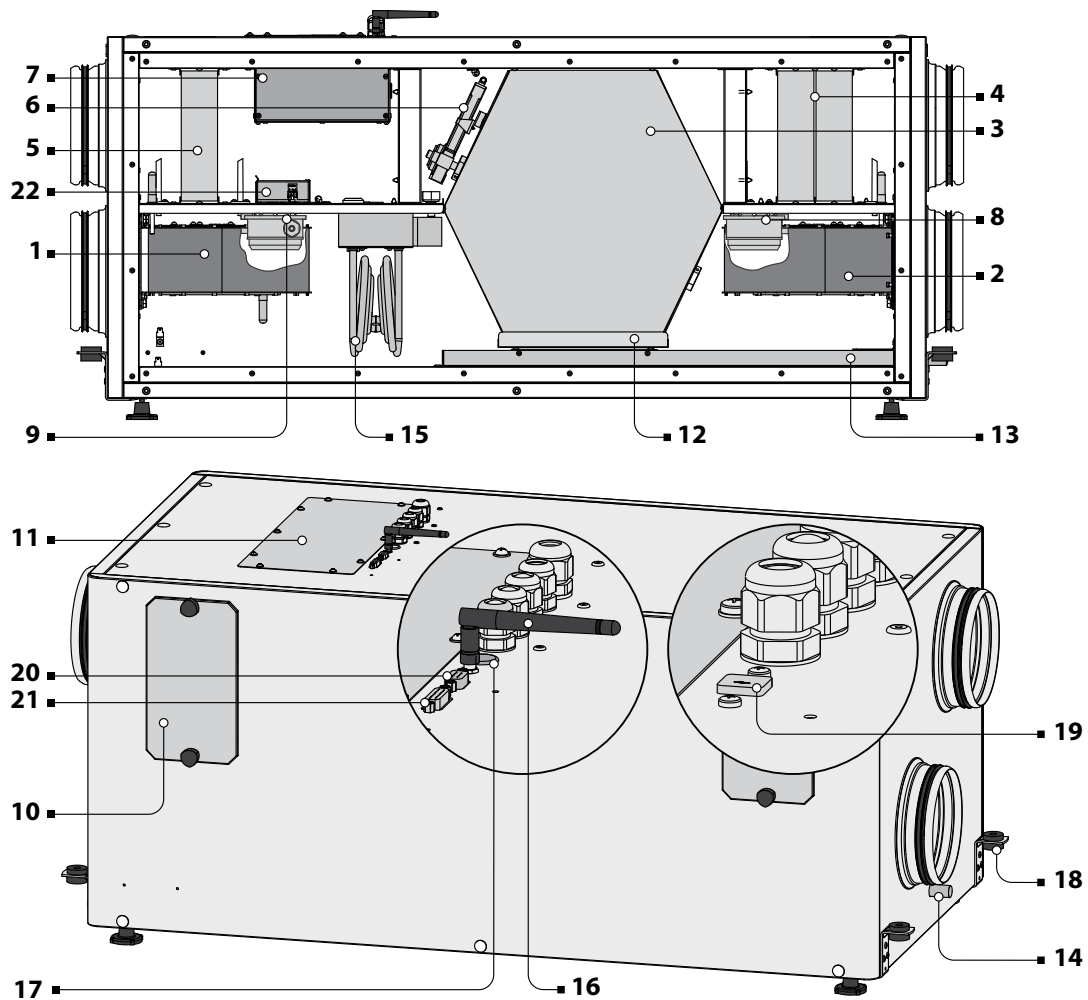

Air handling unit: **VUT ... HB EC VUE ... HB EC VUT ... HBE EC VUE ... HBE EC**
Controller: **A14 A21 A14 A21 A21 A21**

	VUT ... HB EC	VUE ... HB EC	VUT ... HBE EC	VUE ... HBE EC
1 Supply fan	•	•	•	•
2 Extract fan	•	•	•	•
3 Counter-flow heat exchanger	•	•	•	•
4 Supply filters	•	•	•	•
5 Extract filter	•	•	•	•
6 Bypass damper actuator	•	•	•	•
7 Control unit	•	•	•	•
8 Differential pressure switch for monitoring supply filter clogging		•	•	•
9 Differential pressure switch for monitoring extract filter clogging		•	•	•
10 Filter maintenance access hole	•	•	•	•
11 Inspection hatch for access to the control unit	•	•	•	•
12 Condensate drip tray	•	•		•
13 Condensate drain pan	•	•	•	•
14 Drain pipe	•	•		•
15 Supply air reheater			•	•
16 Wi-Fi antenna		•	•	•
17 Set Up Mode on/off button		•	•	•
18 Brackets for suspended mounting	•	•	•	•
19 USB connector (service)	•	•		
20 Connector for an NKP duct electric preheater connection		•	•	•
21 Connector for an NKD duct electric reheater connection		•	•	
22 HV2 humidity sensor (purchased separately)	•	•	•	•

AIR FLOW DIRECTION

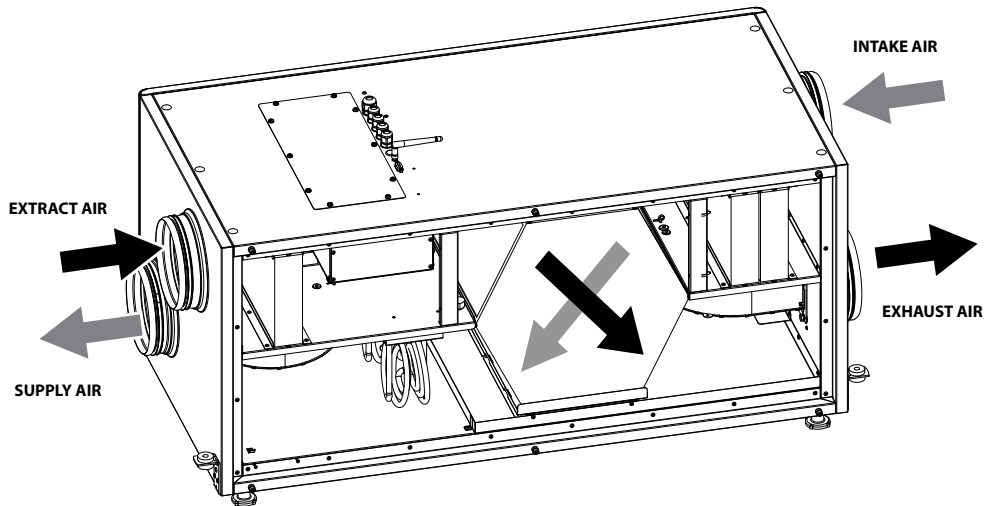

SERVICE SIDE CHANGE

Remove the plugs from the panels on the service side and on the opposite side of the unit. Undo the screws securing the panels and remove them. Remove the heat exchanger with a condensate drip tray.

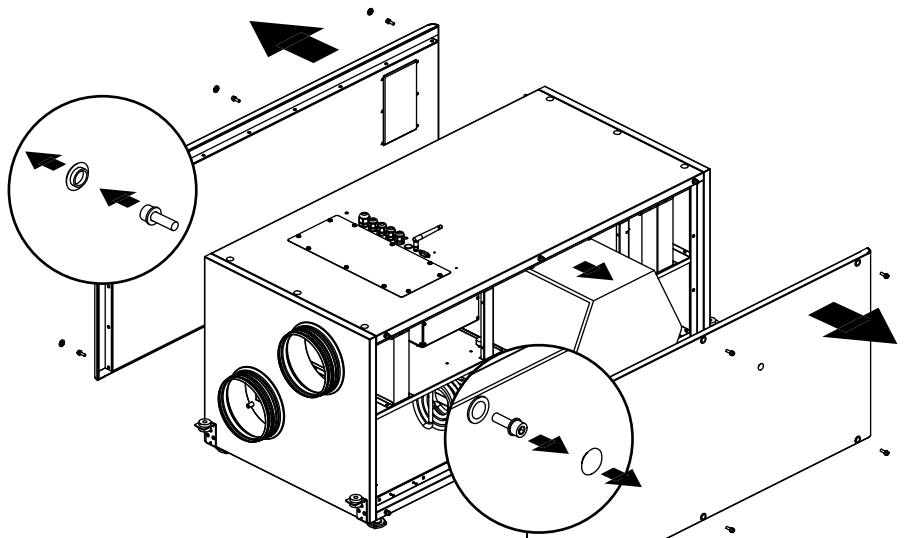

Install the panel which is not a service side on the opposite side. Move the block with the bypass damper against the stop with the panel and install the heat exchanger with the condensate drip tray to the unit. Fix the front panel (service side) using screws. Close the screw caps with the plugs on both sides.

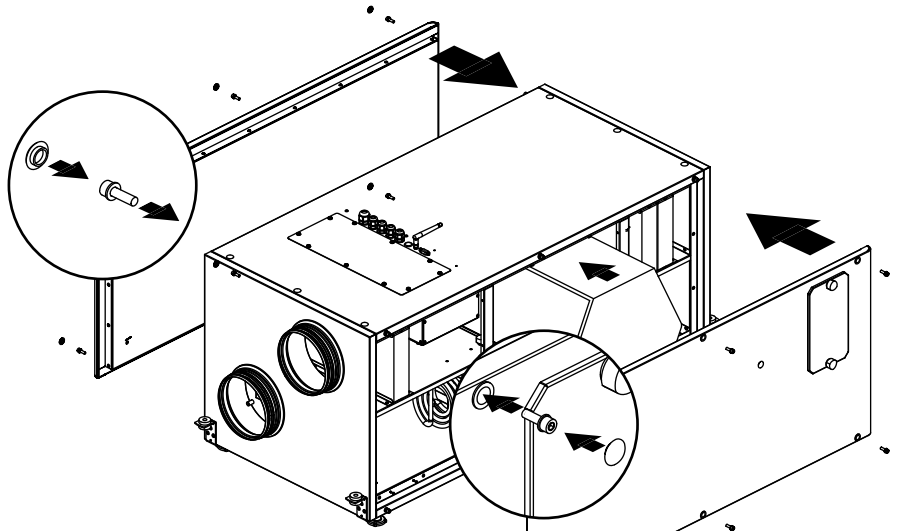

INSTALLATION AND SET-UP



READ THE USER'S MANUAL BEFORE INSTALLING THE UNIT.



WHILE INSTALLING THE UNIT ENSURE CONVENIENT ACCESS FOR SUBSEQUENT MAINTENANCE AND REPAIR.

HV2 HUMIDITY SENSOR INSTALLATION AND CONNECTION

CAUTION! The humidity sensor in the exhaust air duct should be installed and connected before the unit mounting.

- Undo the screws on the front panel and remove it.
- Install the humidity sensor in the mount.
- Connect the sensor to the control unit using a cable with a connector (installed by the manufacturer).

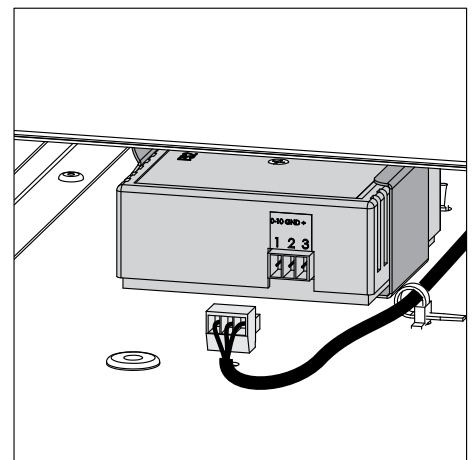
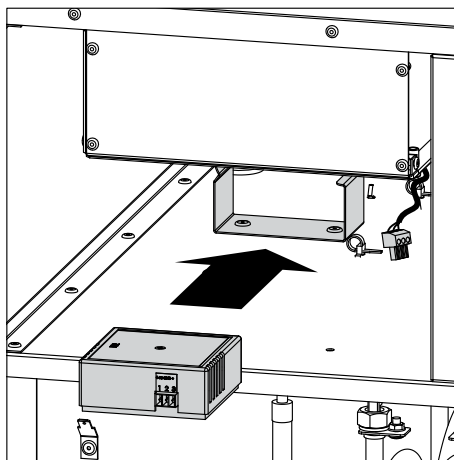
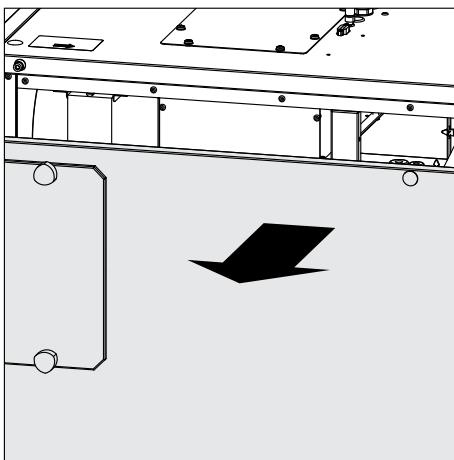

UNIT INSTALLATION

Suspended ceiling mounting

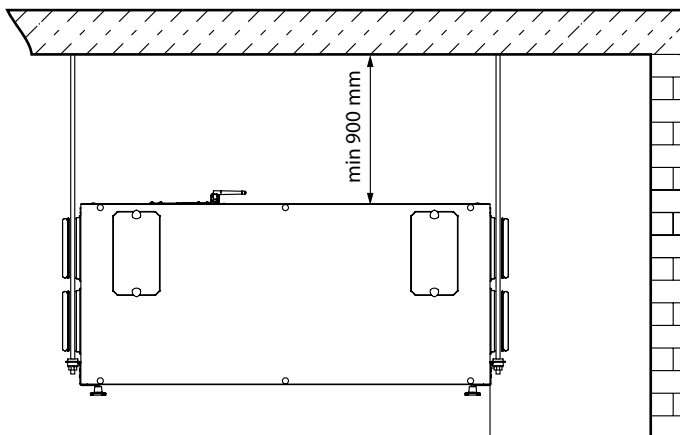

Unit floor mounting

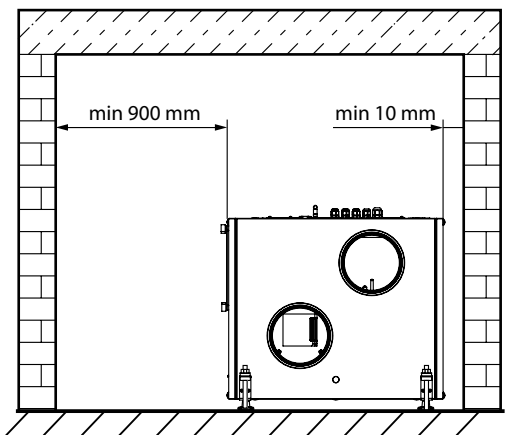

The unit can be suspended on threaded studs or fixed to a horizontal surface using anchor bolts.

Fasteners for mounting the unit are purchased separately. While choosing fasteners consider the material of the mounting surface as well as the weight of the unit, refer to the "Technical data" section. Fasteners for unit installation should be selected by a qualified technician.

CAUTION! To get the best performance of the unit and to minimize turbulence-induced air pressure losses, connect the straight air duct section to the spigots on both sides of the unit while installing. Minimum straight air duct length: equal to 1 air duct diameter on intake side equal to 3 air duct diameters on outlet side.

If the air ducts are too short or not connected, protect the unit parts from ingress of foreign objects. To prevent uncontrollable access to the fan the spigots may be covered with a protecting grille or other protecting device with mesh width not more than 12.5 mm.

CONDENSATE DRAINAGE

All the VUT and VUE units are equipped with a drain pan.

The drain pan in energy recovery units (VUE) is not used, since condensate is not formed due to the transfer of moisture from one air stream to the other through the enthalpy membrane.

Temperature differences between supply and extract air flows in heat recovery units (VUT) lead to condensate formation. Condensate is formed in the heat exchanger, then it is collected in the drain pan and removed outside by the drain pipes. Connect the part of the drain hose at the outside of the unit to the sewage system.

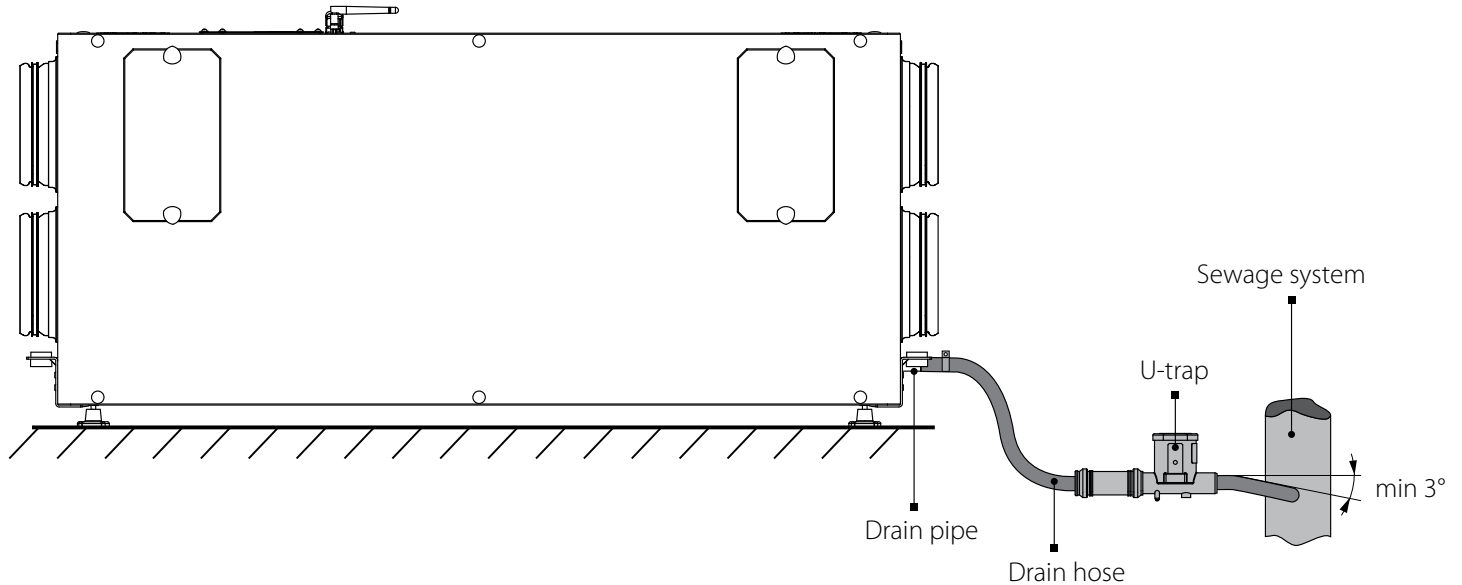

CAUTION!

To ensure the flow of water, pipes must be mounted with a slope of at least 3°.

Provide free drainage for the condensed water, otherwise it is accumulated inside the unit that may cause the equipment damage and condensate outflow to the room.

The condensate drainage system is designed for normal operation in premises with air temperatures above 0 °C!

If the expected ambient air temperatures are below 0 °C, the condensate drainage system must be equipped with heat insulation and pre-heating facilities.

CONNECTION TO POWER MAINS



**DISCONNECT THE POWER SUPPLY PRIOR TO ANY OPERATIONS WITH THE UNIT.
CONNECTION OF THE UNIT TO POWER MAINS IS ALLOWED BY A QUALIFIED
ELECTRICIAN WITH A WORK PERMIT FOR THE ELECTRIC UNITS UP TO 1000 V AFTER
CAREFUL READING OF THE PRESENT USER'S MANUAL. THE RATED ELECTRICAL
PARAMETERS OF THE UNIT ARE GIVEN ON THE MANUFACTURER'S LABEL.
ANY TAMPERING WITH THE INTERNAL CONNECTIONS IS PROHIBITED AND WILL VOID
THE WARRANTY.**

- The unit is rated for connection to 1~220-240 V/50 (60) Hz power mains.
- The unit must be connected to power mains using insulated electric conductors (cables, wires). The actual wire cross section selection must be based on the maximum load current, maximum conductor temperature depending on the wire type, insulation, length and installation method.
- The external power input must be equipped with an automatic circuit breaker built into the stationary wiring to open the electric circuit in case of overload or short-circuit. The circuit breaker installation place must provide quick access for emergency shutdown of the unit. The trip current of the automatic circuit breaker **QF** must exceed the maximum current consumption of the unit (refer to the technical data table). The recommended trip current of the circuit breaker is the next current in the standard trip current row following the maximum current of the connected unit. The automatic circuit breaker is not included in the delivery set.

The control unit is positioned inside the unit casing.

To access the control unit, remove the fixing screws on the service hatch and remove it.

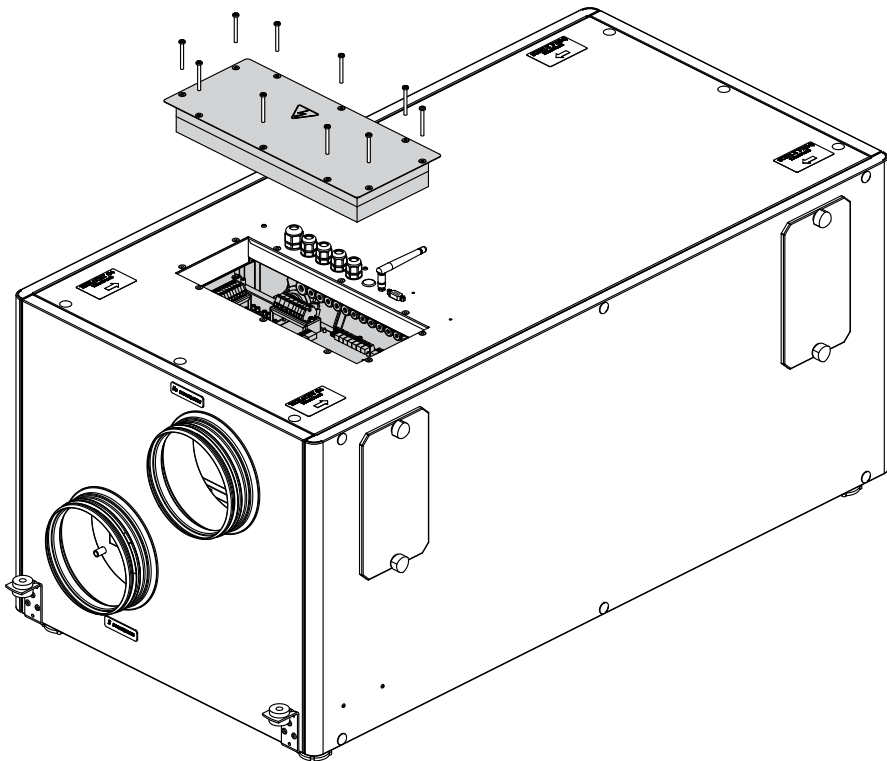

Wiring diagram
(unit with an A14 controller)

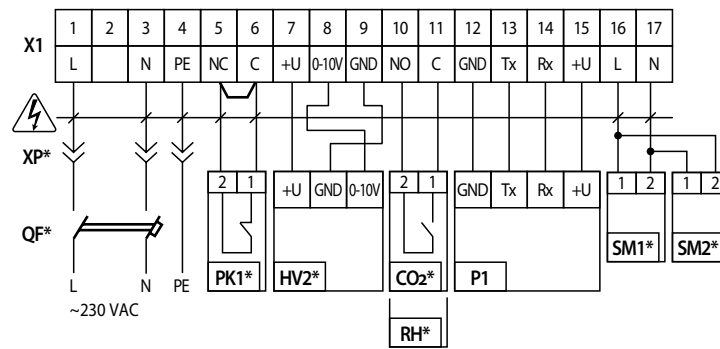

Designation	Unit name	Cable type	Maximum cable length	Note
SM1*	Supply air damper actuator	2x0.75 mm ²	20 m	
SM2*	Extract air damper actuator	2x0.75 mm ²	20 m	
PK1*	Contact from a fire alarm panel	2x0.75 mm ²	20 m	Remove the jumper during installation
P1	Control panel	4x0.25 mm ²	10 m	
CO2* or RH*	CO ₂ concentration and indoor humidity sensor			
HV2*	Humidity sensor in the exhaust air duct inside the unit			
XP*	Electric plug			
QF*	Automatic circuit breaker			
X1	Terminal block			

Wiring diagram
(unit with an A21 controller)

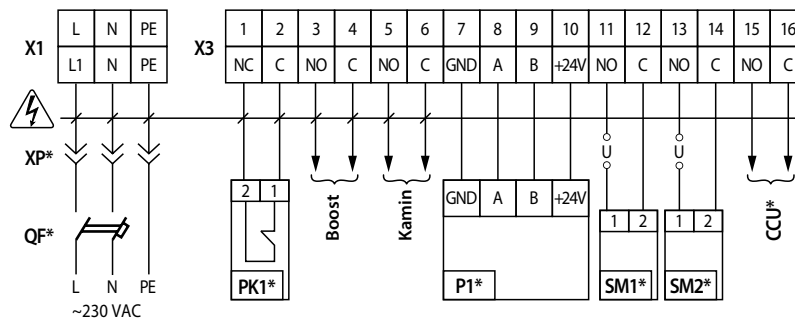

Designation	Unit name	Cable type	Maximum cable length	Note
CCU*	Compressor-condenser unit	2x0.75 mm ²	20 m	3 A. 30 DC/~250 AC
SM1*	Supply air damper actuator	2x0.75 mm ²	20 m	3 A. 30 DC/~250 AC
SM2*	Extract air damper actuator	2x0.75 mm ²	20 m	3 A. 30 DC/~250 AC
PK1*	Contact from a fire alarm panel	2x0.75 mm ²	20 m	
P1*	Control panel	4x0.25 mm ²	10 m	
HV2*	Humidity sensor in the exhaust air duct inside the unit			
XP*	Electric plug			
QF*	Automatic circuit breaker			
X1. X3	Terminal blocks			
Boost	Contact on/off. Boost mode			
Kamin	Contact on/off. Kamin mode			

*Additionally connected devices are purchased separately. The connection must be made using durable, insulated and heat-resistant conductors (cables, wires). Requirements to a connection cable are shown in the table.

UNIT CONTROL

The unit is controlled:

With a wired wall control panel in units with an A14 controller (included in the delivery set).

With a mobile application and/or a wired and wireless wall panel (purchased separately) in units with an A21 controller (included in the delivery set).

CAUTION! Control panel functions, mobile application operation and download links are given in corresponding user's manuals.

TECHNICAL MAINTENANCE



**DISCONNECT THE UNIT FROM POWER SUPPLY BEFORE
ANY MAINTENANCE OPERATIONS!**

Maintenance operations of the unit are required 3-4 times per year. They include general cleaning of the unit and the following operations:

1. Filter maintenance.

Dirty filters increase air resistance in the system and reduce supply air volume. The filters require cleaning not less than 3-4 times per year. Vacuum cleaning is allowed. After two consecutive cleanings filters must be replaced. For new filters, contact the Seller.

Filter maintenance sequence:

1. Unscrew the hand screws on the detachable plates and remove them.
2. Pull the dirty filters to remove.
3. Clean the filters with a vacuum cleaner.
4. Put the filters in place and assemble the unit in the reverse order.

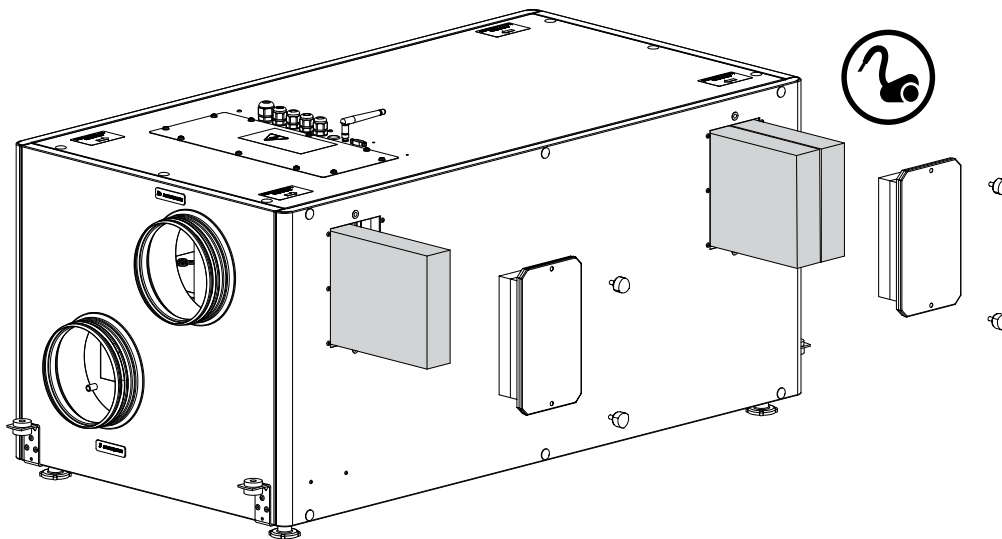

2. Heat exchanger maintenance (once per year).

Some dust may accumulate on the heat exchanger even in case of regular maintenance of the filters. To maintain the high heat recovery efficiency, regular cleaning is required. To clean the heat exchanger, remove it from the unit and clean the heat exchanger by using compressed air or a vacuum cleaner. After cleaning, re-install the heat exchanger into the unit.

Heat exchanger maintenance steps:

1. Undo the screws on the front panel and remove it.
2. Pull the heat exchanger with a condensate drip tray to remove them.
3. Remove the heat exchanger from the condensate drip tray.
4. Clean the heat exchanger.
 - Wet cleaning (polystyrene heat exchanger): rinse the heat exchanger with a warm detergent solution and leave to dry.
 - Dry cleaning (enthalpy heat exchanger): clean the heat exchanger with a vacuum cleaner using a slotted nozzle.
5. Put the heat exchanger in place and assemble the unit in the reverse order.

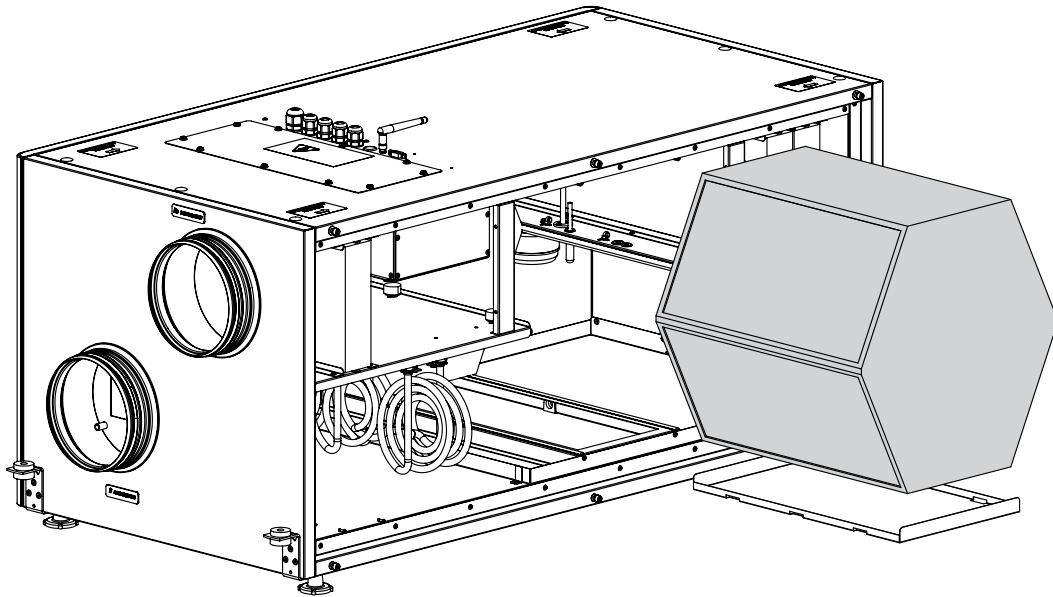

3. Fan maintenance (once per year).

Even in case of regular maintenance of the filters, some dust may accumulate inside the fans and reduce the fan performance and supply air flow. Clean the fans with a soft cloth, brush, or using compressed air. Do not use water, aggressive solvents, or sharp objects as they may damage the impeller.

4. Supply air flow control (twice per year).

The supply duct grille may get clogged with leaves and other objects reducing the unit performance and supply air delivery. Check the supply grille twice per year and clean it as required.

5. Ductwork system maintenance (once in 5 years).

Even regular fulfilling of all the maintenance operations prescribed above may not completely prevent dirt accumulation in the air ducts, which leads to air pollution and reduces the unit capacity. Duct maintenance means regular cleaning or replacement.

6. Control unit maintenance (if necessary).

Accessing the control unit is shown in the "Connection to power mains" section.

TROUBLESHOOTING

PROBLEM	POSSIBLE REASONS	TROUBLESHOOTING
The fan(s) does not start when the unit is on.	No power supply.	Make sure the power supply line is connected correctly, otherwise troubleshoot the connection error.
	The motor is jammed, the impeller blades are soiled.	Turn the unit off. Troubleshoot the motor jam and the impeller clogging. Clean the blades. Restart the unit.
Automatic circuit breaker trips following the unit turning on.	High current consumption caused by a short circuit.	Turn the unit off. Contact the Seller.
Low air flow.	Low set fan speed.	Set higher speed.
	The filters and the fans are clogged, the heat exchanger is clogged.	Clean or replace the filters, clean the fans, and the heat exchanger.
	Ventilation system elements (air ducts, diffusers, louver shutters, grilles) are clogged, damaged, or closed.	Clean or replace the ventilation system elements, such as air ducts, diffusers, louver shutters, grilles.
Cold supply air.	The extract filter is soiled.	Clean or replace the extract filter.
	The heat exchanger is soiled.	Clean the heat exchanger.
Noise, vibration.	The impeller(s) is soiled.	Clean the impeller(s).
	The fan or casing screw connection is loose.	Tighten the screw connection of the fans or the casing against stop.
	No anti-vibration connectors on air duct pipe flanges.	Install anti-vibration connectors.
Water leakage (only for the VUT units).	The drainage system is soiled, damaged, or installed incorrectly.	Clean the drain line. Check the drain line slope angle. Make sure that the U-trap is filled with water and the drain pipes are frost protected.

STORAGE AND TRANSPORTATION REGULATIONS

- Store the unit in the manufacturer's original packaging box in a dry closed ventilated premise with temperature range from +5 °C to +40 °C and relative humidity up to 70 %.
- Storage environment must not contain aggressive vapors and chemical mixtures provoking corrosion, insulation, and sealing deformation.
- Use suitable hoist machinery for handling and storage operations to prevent possible damage to the unit.
- Follow the handling requirements applicable for the particular type of cargo.
- The unit can be carried in the original packaging by any mode of transport provided proper protection against precipitation and mechanical damage. The unit must be transported only in the working position.
- Avoid sharp blows, scratches, or rough handling during loading and unloading.
- Prior to the initial power-up after transportation at low temperatures allow the unit to warm up at operation temperature for at least 3-4 hours.

MANUFACTURER'S WARRANTY

The product is in compliance with EU norms and standards on low voltage guidelines and electromagnetic compatibility. We hereby declare that the product complies with the provisions of Electromagnetic Council Directive 2014/30/EU, Low Voltage Directive 2014/35/EU and CE-marking Directive 93/68/EEC. This certificate is issued following test carried out on samples of the product referred to above. The manufacturer hereby warrants normal operation of the unit for 24 months after the retail sale date provided the user's observance of the transportation, storage, installation, and operation regulations. Should any malfunctions occur in the course of the unit operation through the Manufacturer's fault during the guaranteed period of operation, the user is entitled to get all the faults eliminated by the manufacturer by means of warranty repair at the factory free of charge. The warranty repair includes work specific to elimination of faults in the unit operation to ensure its intended use by the user within the guaranteed period of operation. The faults are eliminated by means of replacement or repair of the unit components or a specific part of such unit component.

The warranty repair does not include:

- routine technical maintenance
- unit installation/dismantling
- unit setup

To benefit from warranty repair, the user must provide the unit, the user's manual with the purchase date stamp, and the payment paperwork certifying the purchase. The unit model must comply with the one stated in the user's manual. Contact the Seller for warranty service.

The manufacturer's warranty does not apply to the following cases:

- User's failure to submit the unit with the entire delivery package as stated in the user's manual including submission with missing component parts previously dismantled by the user.
- Mismatch of the unit model and the brand name with the information stated on the unit packaging and in the user's manual.
- User's failure to ensure timely technical maintenance of the unit.
- External damage to the unit casing (excluding external modifications as required for installation) and internal components caused by the user.
- Redesign or engineering changes to the unit.
- Replacement and use of any assemblies, parts and components not approved by the manufacturer.
- Unit misuse.
- Violation of the unit installation regulations by the user.
- Violation of the unit control regulations by the user.
- Unit connection to power mains with a voltage different from the one stated in the user's manual.
- Unit breakdown due to voltage surges in power mains.
- Discretionary repair of the unit by the user.
- Unit repair by any persons without the manufacturer's authorization.
- Expiration of the unit warranty period.
- Violation of the unit transportation regulations by the user.
- Violation of the unit storage regulations by the user.
- Wrongful actions against the unit committed by third parties.
- Unit breakdown due to circumstances of insuperable force (fire, flood, earthquake, war, hostilities of any kind, blockades).
- Missing seals if provided by the user's manual.
- Failure to submit the user's manual with the unit purchase date stamp.
- Missing payment paperwork certifying the unit purchase.



FOLLOWING THE REGULATIONS STIPULATED HEREIN WILL ENSURE A LONG AND TROUBLE-FREE OPERATION OF THE UNIT.



USER'S WARRANTY CLAIMS SHALL BE SUBJECT TO REVIEW ONLY UPON PRESENTATION OF THE UNIT, THE PAYMENT DOCUMENT AND THE USER'S MANUAL WITH THE PURCHASE DATE STAMP.

CERTIFICATE OF ACCEPTANCE

Unit Type	Heat recovery air handling unit
Model	VUT/VUE _____ HB(E) EC A__
Serial Number	
Manufacture Date	
Quality Inspector's Stamp	

SELLER INFORMATION

Seller	
Address	
Phone Number	
E-mail	
Purchase Date	
This is to certify acceptance of the complete unit delivery with the user's manual. The warranty terms are acknowledged and accepted.	
Customer's Signature	

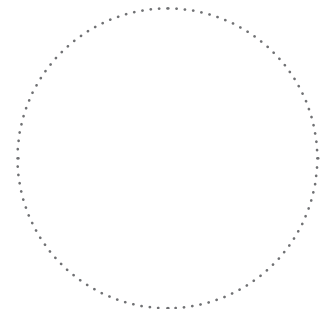

Seller's Stamp

INSTALLATION CERTIFICATE

The VUT/VUE _____ HB(E) EC A__ unit has been connected to power mains pursuant to the requirements stated in the present user's manual.	
Seller	
Address	
Phone Number	
Installation Technician's Full Name	
Installation Date:	Signature:
The unit has been installed in accordance with the provisions of all the applicable local and national construction, electrical and technical codes and standards. The unit operates normally as intended by the manufacturer.	
Signature:	

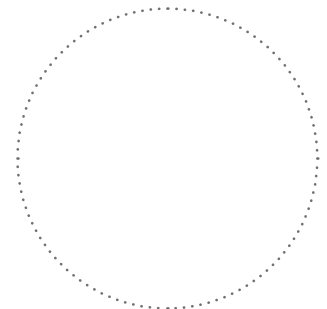

Installation Stamp

WARRANTY CARD

Unit Type	Heat recovery air handling unit
Model	VUT/VUE _____ HB(E) EC A__
Serial Number	
Manufacture Date	
Purchase Date	
Warranty Period	
Seller	

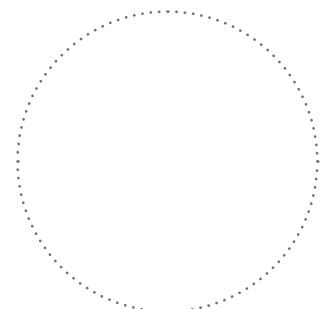

Seller's Stamp



Μιχαήλ Καραολή 19, τκ 143 43, Ν. Χαλκηδόνα, Αθήνα
Τηλ: 211 - 70.55.500 & 210 - 21.30.051, Fax: 210 - 22.23.283

