



**model**  
**VENTS Quietline**

EN

AXIAL FANS  
user's manual





**WARNING**

**Follow the user's manual requirements to ensure durable and trouble-free operation of the fan.**



Disconnect the fan from power supply prior to any connection, servicing and repair operations.

**Only duly qualified electricians with valid electrical permit for electric operations at the units with operating voltage up to 1000 V are allowed for mounting and maintenance after careful study of the present user's manual.**

The single-phase power mains must comply with the acting local electrical norms and standards.

The fixed electrical wiring must be equipped with an automatic circuit breaker.

The fan must be connected to power mains through an automatic circuit breaker QF integrated into the fixed wiring system with the gap between the breaker contacts on all poles not less than 3 mm.

Check the fan for any visible damages of the impeller and the casing before starting installation. The casing internals must be free of any foreign objects which can damage the impeller blades.

Due to constant improvements the design of some models may slightly differ from those ones described herein.

**Follow the user's manual requirements to ensure durable and trouble-free operation of the fan.**



**WARNING**

While mounting the fan do not compress the casing!

Deformation of the casing may result in the motor jam and noisy operation.

Misuse of the fan and any unauthorised modifications are not allowed.

Take steps to prevent ingress of smoke, carbon monoxide and other combustion products into the room through open chimney flues or other fire-protection devices. Sufficient air supply must be provided for proper combustion and exhaust of gases through the chimney of fuel burning equipment to prevent back drafting.

Transported air must not contain any dust or other solid impurities, sticky substances or fibrous materials.



## WARNING

**Follow the user's manual requirements to ensure durable and trouble-free operation of the fan.**

Do not use the fan in a hazardous or explosive environment containing spirits, gasoline, insecticides, etc.

Do not close or block the fan intake or extract vents in order to ensure the efficient stream.

Do not sit on the fan and do not put objects on it.

The timer circuit is live.

Disconnect the fan from power supply prior to any adjustment operations.

The fan delivery set includes a specially designed plastic screwdriver for adjustment of the fan parameters.

Use the plastic screwdriver to change the turn-off delay time.

**Follow the user's manual requirements to ensure durable and trouble-free operation of the fan.**



**WARNING**

The product is allowed to be used by children aged from 8 years and above and persons with reduced physical, sensory or mental capabilities or lack of experience and knowledge provided that they have been given supervision or instruction regarding a safe use of the product and understand the risks involved.

Do not allow children play with the product.



***The product must be collected separately at the end of service life.***

***Do not dispose of as unsorted municipal waste.***

Read the user's manual carefully before proceeding with installation works.  
**Compliance with the manual requirements ensures reliable operation and long service life of the product. Keep the user's manual available as long as you use the product. You may need to re-read the information on the product servicing.**

### DELIVERY SET

1. Fan - 1 item
  2. Screws and dowels - 4 items
  3. Retaining cable clamp\* - 1 item
  4. Fixing bracket (applicable for Quietline-k) - 1 item
  5. Screws for retaining cable clamp\* - 2 items;
  6. User's manual - 1 item
  7. Packing box
- \* - except for the models with a power cable

### BRIEF DESCRIPTION

The products is an axial fan for exhaust or supply ventilation of small to medium-sized premises. The fan is designed for connection to 100, 125 and 150 mm air ducts.

Modifications:

k: fan with a fixing bracket

R: fan with a power cable and a plug

T: fan with a controllable timer (for details please refer to electronic control logic)

K: fan with a back valve to prevent back air flow during the fan standby

DUO: fan with a two speed motor

Extra: fan with a high-powered two speed motor

Q: fan with a low-speed motor

12: fan with a safe voltage 12V / 50 Hz motor

### OPERATION GUIDELINES

The fan is rated for connection to AC single-phase 220...240 V / 50 Hz or 220...240 V / 60 Hz power supply, depending on the fan model type.

Quietline 12 and is rated for connection to 12 V, 50 Hz power mains directly or to AC 220-240 V, 50 Hz power supply via a step-down transformer, for example, TRF 220/12-25 (not included in the delivery set, available upon separate order).

The fan is rated for operation at the ambient air temperature from +1 °C up to +45 °C.

Ingress protection rating against access to hazardous parts and water ingress is IP X4.

The fan requires no grounding.

### MOUNTING

The fan is designed for vertical or horizontal installation and connection to a round air duct of a matching diameter, Fig. 1-3. Attention!

In case of vertical mounting the fan must be protected against ingress of rainfalls and condensate inside the fan.

Fan installation with direct air discharge upwards is not allowed, Fig. 3.

Use the supplied fixing bracket for mounting.  
Attachment of the fixing bracket to the fan is shown in Fig. 4.  
Fan mounting steps are shown in Fig. 5-12.  
Wiring options are shown in Fig. 13-16.

## ELECTRONIC CONTROL LOGIC

Quietline 100/125/150 T starts operation as the external switch supplies a control signal to the LT input terminal, for instance, during switching the light on.

After the control signal is off the fan continues operating for the set time as adjusted from 2 to 30 min and then stops.  
100/125/150 Quietline T DUO / 150 Quietline Extra T have four operation modes.

The operation mode is selected by setting the DIP switch into a respective position.

Use the supplied plastic screwdriver to set the DIP-switch to a required position.



### Operation mode 1 (single-speed mode)

The fan is turned off in the initial position.

The fan starts operating at speed 2 as the external switch supplies a control signal to the LT input terminal, for instance, during switching the light on. After the control signal is off the fan continues operating for the set time as adjusted from 2 to 30 min and then turns off.



### Operation mode 2 (single-speed mode)

The fan is turned off in the initial position.

The fan starts operating at speed 1 as the external switch supplies a control signal to the LT input terminal, for instance, during switching the light on. After the control signal is off the fan continues operating for the set time as adjusted from 2 to 30 min and then turns off.



### Operation mode 3 (two-speed mode)

The fan operates at speed 1 in the initial position.

The fan starts operating at speed 2 as the external switch supplies a control signal to the LT input terminal, for instance, during switching the light on. After the control signal is off the fan continues operating for the set time as adjusted from 2 to 30 min and then switches to speed 1.



### Operation mode 4 (two-speed mode)

The fan operates at speed 1 in the initial position.

The fan switches to speed 2 after elapse of the set time as adjusted from 1 to 15 hours and runs at the speed 2 from 2 to 30 min, then returns to the speed 1. The fan starts operating at speed 2 as the external switch supplies a control signal to the LT input terminal, for instance, during switching the light on. After the control signal is off the fan continues operating for the set time as adjusted from 2 to 30 min and then switches to speed 1.

## ATTENTION!

By default the operation mode 1 is activated.

Another operation mode may be selected during mounting of the fan or during its operation.

## TIMER ADJUSTMENT

100/125/150 Quietline T (Fig. 17)

 **T<sub>off</sub>** To adjust the fan turn-off delay time, rotate the control knob Toff clockwise to increase and counter-clockwise to decrease the turn-off delay time respectively, adjustable from 2 up to 30 minutes.

100/125/150 Quietline T DUO / 150 Quietline Extra T (Fig. 18)

Operation modes 1, 2 and 3

 **T<sub>on</sub>** To adjust the fan turn-on delay time or the speed switch time for the operation mode 3, rotate the control knob Ton clockwise to increase and counter-clockwise to decrease the turn-on delay time respectively, adjustable from 0 up to 2 minutes.

 **T<sub>off</sub>** To adjust the fan turn-off delay time or the speed switch time for the operation mode 3, rotate the control knob Toff clockwise to increase and counter-clockwise to decrease the turn-off delay time respectively, adjustable from 2 up to 30 minutes.

Operation mode 4

 **T<sub>int</sub>** To adjust the interval operation time, rotate the control knob Tint clockwise to increase and counter-clockwise to decrease the switching time respectively, adjustable from 1 up to 15 hours

 **T<sub>off&HS time</sub>** To adjust the operation time at the speed 2 and turn-off delay time for activation of the speed 1 after turning the switch off, rotate the control knob Toff&HS time clockwise to increase and counter-clockwise to decrease respectively, adjustable from 2 up to 30 minutes.

## Warning!

The timer circuit is live!

Disconnect the fan from power supply prior to any adjustment operations.

A supplied specially designed plastic screwdriver is included in the delivery set.

Use it to change the timer settings.

Do not use a metal screwdriver, knife, etc. for adjustment operations not to damage the circuit board.

## MAINTENANCE

Cut off power supply to the fan and take steps to prevent unintentional power supply activation before completion of the maintenance operations.

The fan maintenance periodicity is at least once per 6 months, depending on operation conditions.

Maintenance works include regular cleaning of the fan surfaces of dust and dirt and checking reliability of electrical connections.

Follow the applicable local maintenance safety requirements.



## **TRANSPORTATION AND STORAGE RULES**

Transportation with any transportation vehicle in the manufacturer's original package.

Store the delivered product in the manufacturer's original packing box in a dry ventilated premise with the temperature from +5 °C up to + 40 °C and relative humidity below 80%.

The storage environment must not contain dust, acid or alkali vapours that may cause corrosion of the product parts.

## **MANUFACTURER'S WARRANTY**

The fan is manufactured at the factory of "Ventilation systems" PrJSC (hereinafter referred to as the manufacturer). We hereby declare that the product complies with the essential protection requirements of Electromagnetic Council Directive 2004/108/EC, 89/336/EEC and Low Voltage Directive 2006/95/EC, 73/23/EEC and CE-marking Directive 93/68/EEC on the approximation of the laws of the Member States relating to electromagnetic compatibility. This certificate is issued following test carried out on samples of the product referred to above.

The manufacturer sets forth the warranty period of the fan as 60 months following the sale date via retail network subject to the customer's ensuring compliance with the rules of transportation, storage, mounting and operation. Should any malfunctions occur in the course of the fan operation through the Manufacturer's fault during the guaranteed period of operation the user is entitled to elimination of faults by the manufacturer by means of warranty repair at the factory free of charge.

The warranty repair shall include work specific to elimination of faults in the fan operation to ensure its intended use by the user within the guaranteed period of operation.

The faults are eliminated by means of replacement or repair of the fan components or a specific part of such fan component.

The warranty repair does not include:

Routine technical maintenance;

Fan installation / dismantling;

Fan setup.

To benefit from warranty repair the user must provide the fan, the user's manual with the purchase date stamp and the payment document certifying the purchase.

The fan model must comply with the one stated in the user's manual.

Contact the Seller for warranty service.

The manufacturer's warranty does not apply to the following cases:

User's failure to submit the fan with the entire delivery package as stated in the user's manual including submission with missing component parts previously dismantled by the user.

Mismatch of the fan model and the brand name with the information stated on the fan packing and in the user's manual.

User's failure to ensure timely technical maintenance of the fan.

External damage to the fan casing (excluding external modifications as required for installation) and internal components caused by the user.

Redesign or engineering changes to the fan.

Replacement and use of any assemblies, parts and components not approved by the manufacturer.

Fan misuse.

User's violation of the fan control regulations.

Fan connection to the power mains with a voltage different from the one stated in the user's manual.

Fan breakdown due to voltage surges in the power mains.

Discretionary repair of the fan by the user.

Fan repair by any persons without the manufacturer's authorization.

Expiration of the fan warranty period.

User's violation of the fan transportation regulations.

User's violation of the fan storage regulations.

Wrongful actions against the fan committed by third parties.

Fan breakdown due to circumstances of insuperable force (fire, flood, earthquake, war, hostilities of any kind, blockades).

Missing seals if provided by the user's manual.

Failure to submit the user's manual with the fan purchase date stamp.

Missing payment document certifying the fan purchase.

FOLLOWING THE REGULATIONS STIPULATED HEREIN WILL ENSURE A LONG AND TROUBLE-FREE OPERATION OF THE FAN.

USERS' WARRANTY CLAIMS SHALL BE SUBJECT TO REVIEW ONLY UPON PRESENTATION OF THE FAN, THE PAYMENT DOCUMENT AND THE USER'S MANUAL WITH THE PURCHASE DATE STAMP.

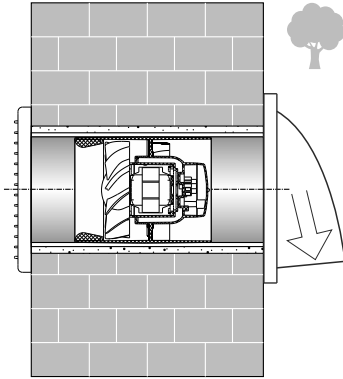

1

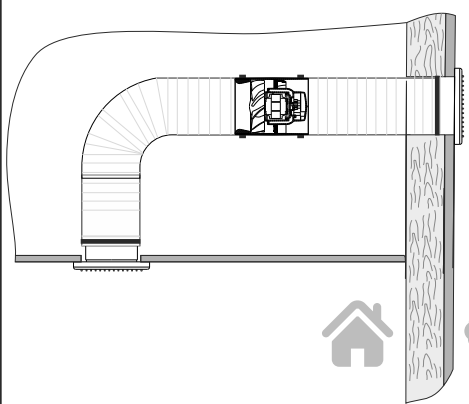

2

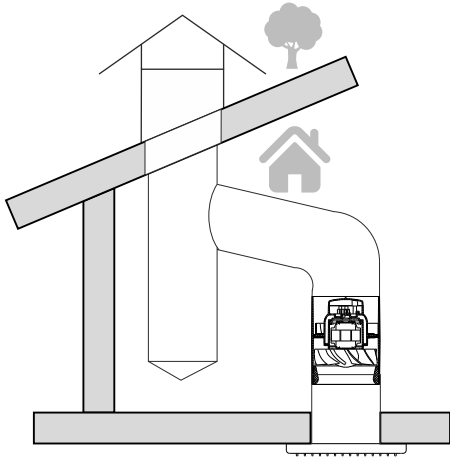

3

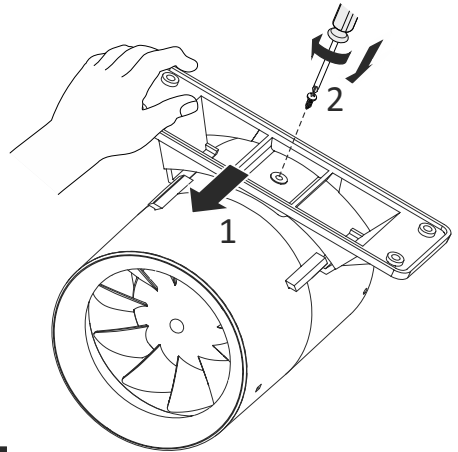

4

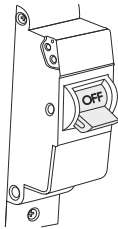
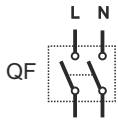

ON  
↓  
OFF

5

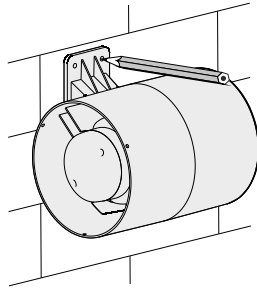

6

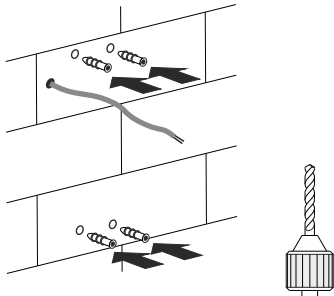

7

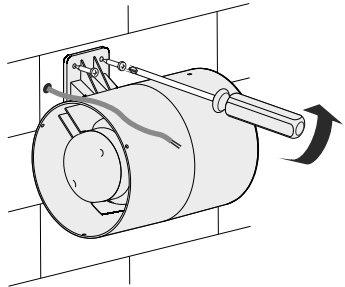

8

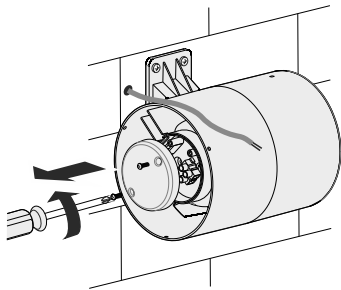

9

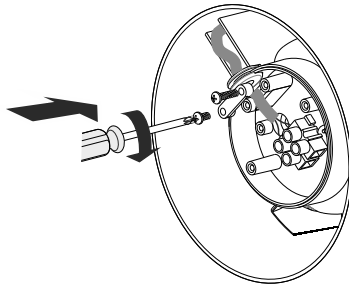

10

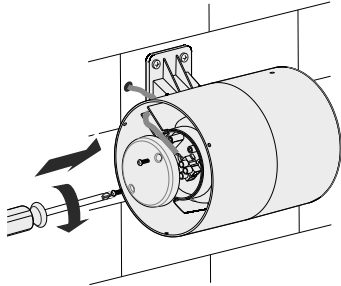

11

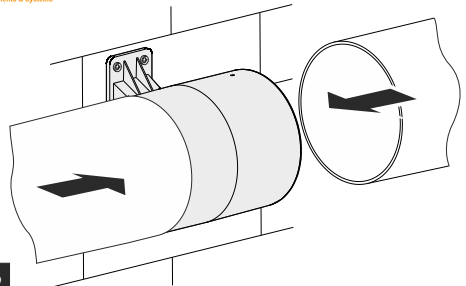

12

**Wiring diagrams**

100/125/150 Quietline

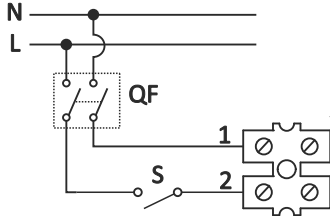

13

100/125/150 Quietline DUO / 150 Quietline Extra

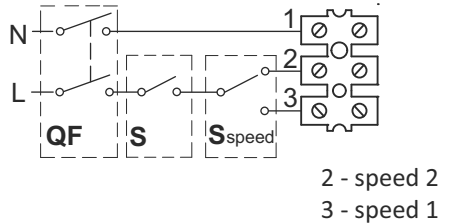

14

100/125/150 Quietline T

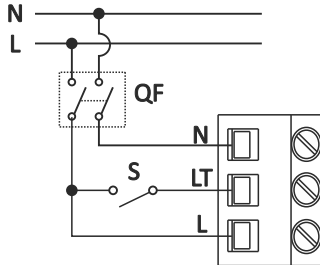

15

100/125/150 Quietline T DUO / 150 Quietline Extra T

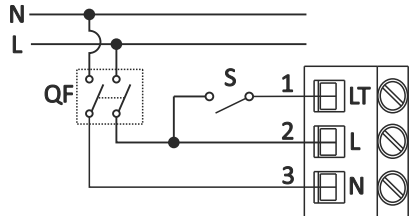

16

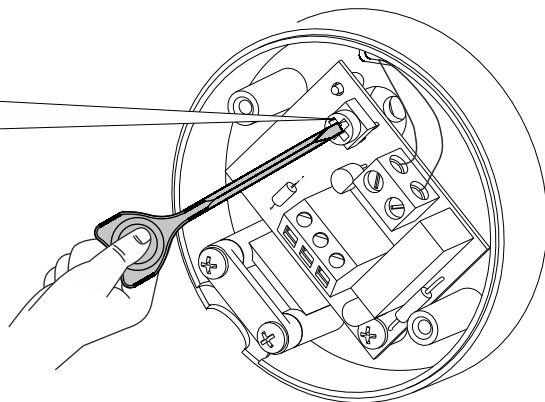
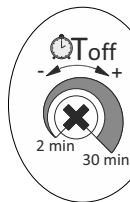
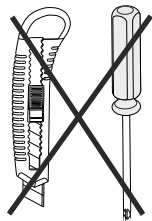

17

100/125/150 Quietline T DUO / 150 Quietline Extra T

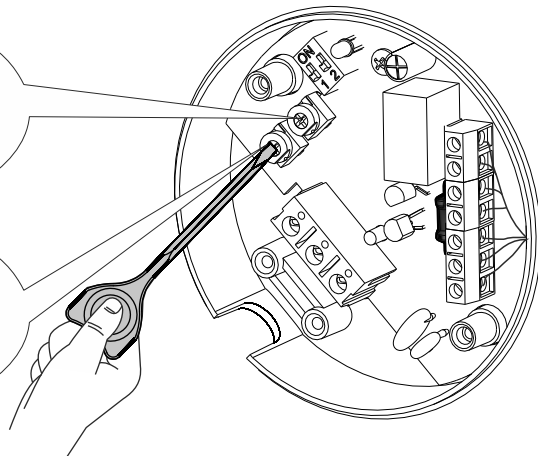
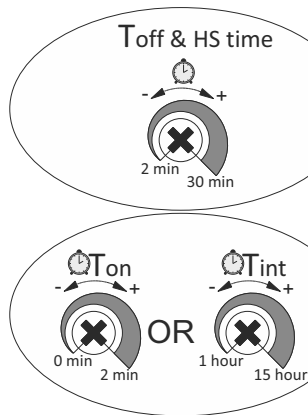
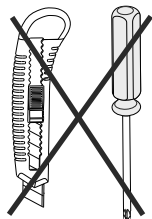

18



# ACCEPTANCE CERTIFICATE

The fan is recognized as serviceable.

Quietline

100

DUO

Quietline  
Extra

125

T

K

Q

Quietline-k

150

R

12

Quietline-k  
Extra



Μιχαήλ Καραολή 19, τκ 143 43, Ν. Χαλκηδόνα, Αθήνα  
Τηλ: 211 - 70.55.500 & 210 - 21.30.051, Fax: 210 - 22.23.283

Approval mark

Manufacturing date

Sold  
(name and stamp of the seller)

Sales date