

USER'S MANUAL

VUT 250 V mini A12
VUE 250 V mini A12
VUT 250 H mini A12
VUE 250 H mini A12

VUT 250 V mini A1
VUE 250 V mini A1
VUT 250 H mini A1
VUE 250 H mini A1

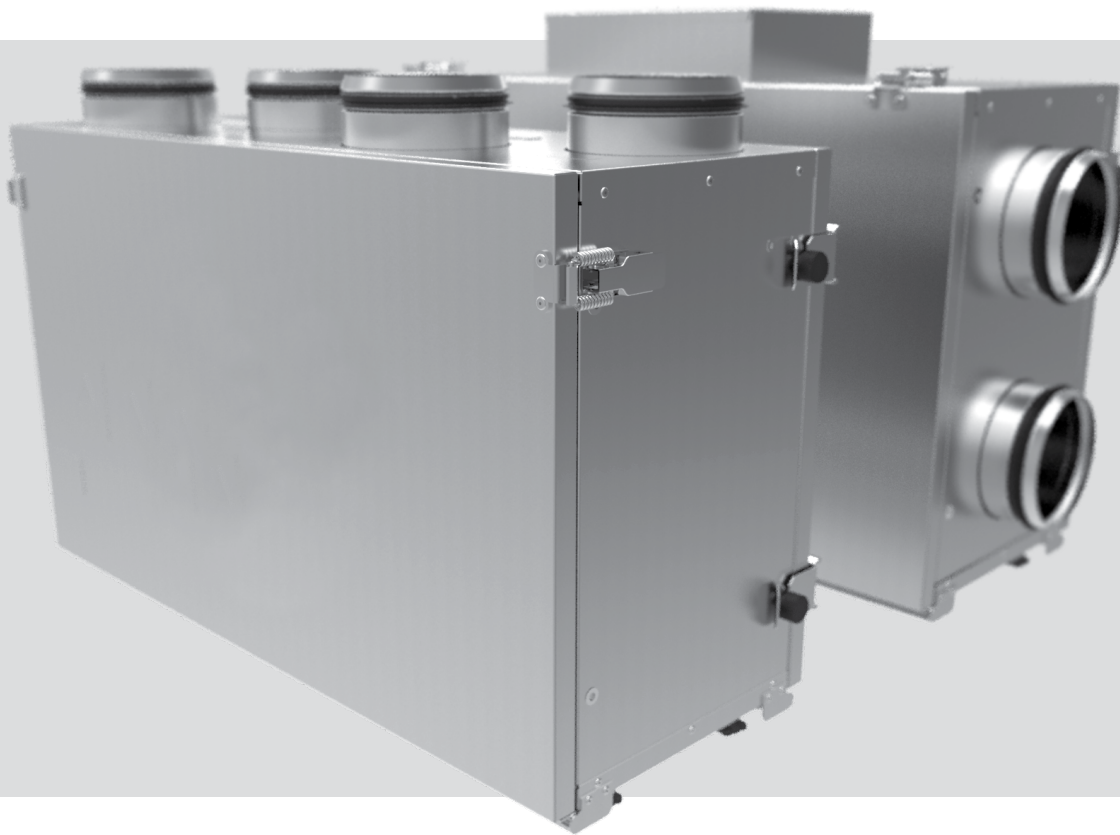

Heat recovery air handling unit

CONTENTS

Safety requirements	2
Purpose	4
Delivery set	4
Designation key	4
Technical data	5
Unit design and operating principle.....	6
Installation and set-up	7
Connection to power mains	13
Unit control.....	14
Technical maintenance	15
Troubleshooting	17
Storage and transportation regulations	17
Manufacturer's warranty.....	18
Certificate of acceptance	19
Seller information.....	19
Installation certificate	19
Warranty card	19

This user's manual consisting of the technical details, operating instructions and technical specification covers the installation and mounting of the VUT/VUE 250 V/H mini A12/A1 heat recovery air handling unit (hereinafter referred to as «the unit»).

SAFETY REQUIREMENTS

Please read the user's manual carefully prior to installing and operating the unit.

All user's manual requirements as well as the provisions of all the applicable local and national construction, electrical, and technical norms and standards must be observed when installing and operating the unit.

The warnings contained in the user's manual must be considered most seriously since they contain vital personal safety information.

Failure to follow the rules and safety precautions noted in this user's manual may result in an injury or unit damage. After a careful reading of the manual, keep it for the entire service life of the unit.

While transferring the unit control, the user's manual must be turned over to the receiving operator.

Symbol legend:

	CAUTION!
	DO NOT!

UNIT INSTALLATION AND OPERATION SAFETY PRECAUTIONS



- Disconnect the unit from power mains prior to any installation operations.



- The unit must be grounded!



- Do not lay the power cable of the unit in close proximity to heating equipment.



- While installing the unit, follow the safety regulations specific to the use of electric tools.



- Do not change the power cable length at your own discretion.
- Do not bend the power cable.
- Avoid damaging the power cable.
- Do not put any foreign objects on the power cable.



- Unpack the unit with care.

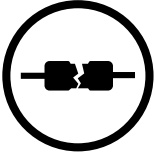

- Do not use damaged equipment or cables when connecting the unit to power mains.



- Do not operate the unit outside the temperature range stated in the user's manual.
- Do not operate the unit in aggressive or explosive environments.



- Do not touch the unit controls with wet hands.
- Do not carry out the installation and maintenance operations with wet hands.»

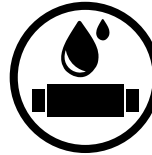

- Do not wash the unit with water.
- Protect the electric parts of the unit against ingress of water.

UNIT INSTALLATION AND OPERATION SAFETY PRECAUTIONS



- Do not allow children to operate the unit.

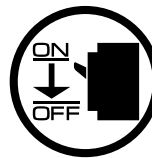

- Disconnect the unit from power mains prior to any technical maintenance.



- Do not store any explosive or highly flammable substances in close proximity to the unit.



- When the unit generates unusual sounds, odour, or emits smoke, disconnect it from power supply and contact the Seller.

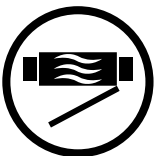

- Do not open the unit during operation.



- Do not direct the air flow produced by the unit towards open flame or ignition sources.



- Do not block the air duct when the unit is switched on.



- In case of continuous operation of the unit, periodically check the security of mounting.

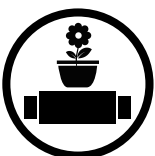

- Do not sit on the unit and avoid placing foreign objects on it.

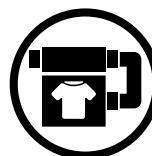

- Use the unit only for its intended purpose.

PURPOSE

Due to the ability to save heating energy by means of energy recovery, the unit is an important element of energy-efficient premises.

The unit is a component part and is not designed for stand-alone operation.

The unit is designed to ensure continuous mechanical air exchange in houses, offices, hotels, cafés, conference halls, and other utility and public spaces as well as to recover the heat energy contained in the air extracted from the premises to warm up the filtered stream of supply air.

The unit is designed for floor and suspended mounting.

The unit is rated for continuous operation.

Transported air must not contain any flammable or explosive mixtures, evaporation of chemicals, sticky substances, fibrous materials, coarse dust, soot and oil particles or environments favourable for the formation of hazardous substances (toxic substances, dust, pathogenic germs).



THE UNIT SHOULD NOT BE OPERATED BY CHILDREN OR PERSONS WITH REDUCED PHYSICAL, MENTAL, OR SENSORY CAPACITIES, OR THOSE WITHOUT THE APPROPRIATE TRAINING.

THE UNIT MUST BE INSTALLED AND CONNECTED ONLY BY PROPERLY QUALIFIED PERSONNEL AFTER THE APPROPRIATE BRIEFING.

THE CHOICE OF UNIT INSTALLATION LOCATION MUST PREVENT UNAUTHORIZED ACCESS BY UNATTENDED CHILDREN.

DELIVERY SET

Name	Number
Air handling unit	1 pc.
User's manual	1 pc.
Control panel	1 pc.
Drain pipe	1 pc.
Installation kit	1 pc.
Packing box	1 pc.

DESIGNATION KEY

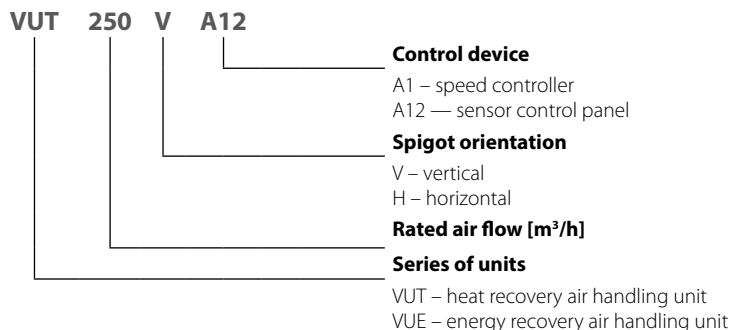

TECHNICAL DATA

The unit is designed for indoor application with the ambient temperature ranging from +1 °C up to +40 °C and relative humidity up to 80 %.

The unit is rated as a Class I electrical appliance.

Hazardous parts access and water ingress protection rating:

- IP44 for the unit motors
- IP22 for the assembled unit connected to the air ducts

The unit design is constantly being improved, thus some models may be slightly different from those described in this manual.

TECHNICAL DATA

Model	VUT 250 V/H mini A12/A1	VUE 250 V/H mini A12/A1
Unit voltage [V /50 (60) Hz]	1~ 230	
Maximum unit power [W]	126	
Maximum unit current [A]	0.6	
Maximum air flow [m ³ /h]	260	
RPM [min ⁻¹]	2700	
Sound pressure level at 3 m distance [dBA]	28-47	
Transported air temperature [°C]	from -25 up to +40	
Insulation	20 mm mineral wool	
Extract filter	G4	
Supply filter	G4 (F8 PM2.5 81 %)*	
Connected air duct diameter [mm]	Ø 125	
Weight [kg]	26	25
Heat recovery efficiency [%]	from 57 up to 78	from 52 up to 73
Humidity recovery efficiency [%]		from 27 up to 45
Heat exchanger type	cross-flow	
Heat exchanger material	polysterene	enthalpy
*Option		

OVERALL DIMENSIONS OF THE UNIT [MM]

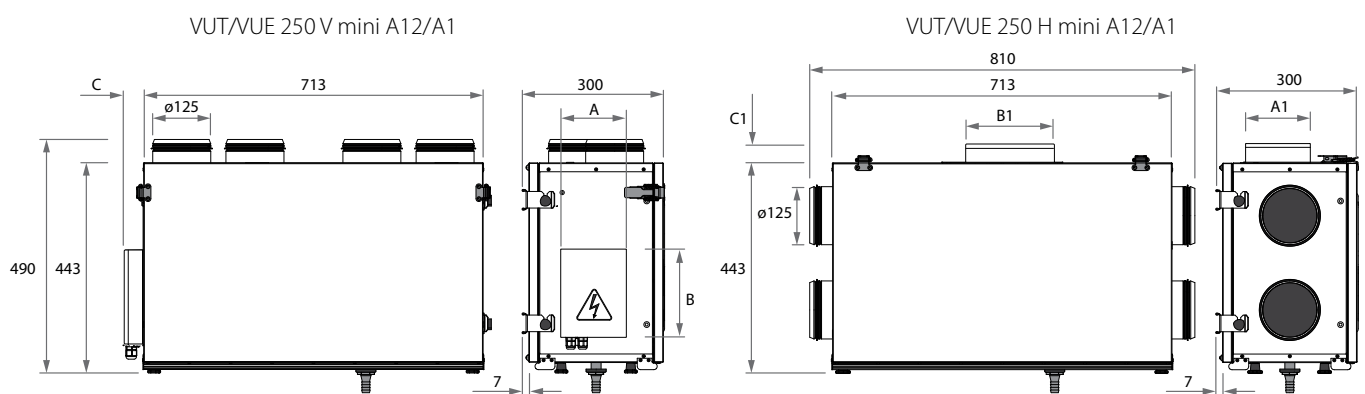

Model	A	A1	B	B1	C	C1
VUT/VUE 250 V mini A12/A1	139	-	186	-	43	-
VUT/VUE 250 H mini A12/A1	-	139	-	186	-	43

DESIGN AND OPERATING PRINCIPLE

Warm stale extract air from the room flows into the unit, where it is filtered by the extract filter, then air flows through the heat exchanger and is exhausted outside by the extract fan.

Clean cold air from outside is moved to the supply filter. Then filtered air flows through the heat exchanger and is moved to the room with the supply fan. Heat energy of warm extract air is transferred to clean intake fresh air from outside and warms it up.

Heat recovery minimizes thermal energy losses and space heating expenses in cold seasons.

UNIT OPERATION LOGIC

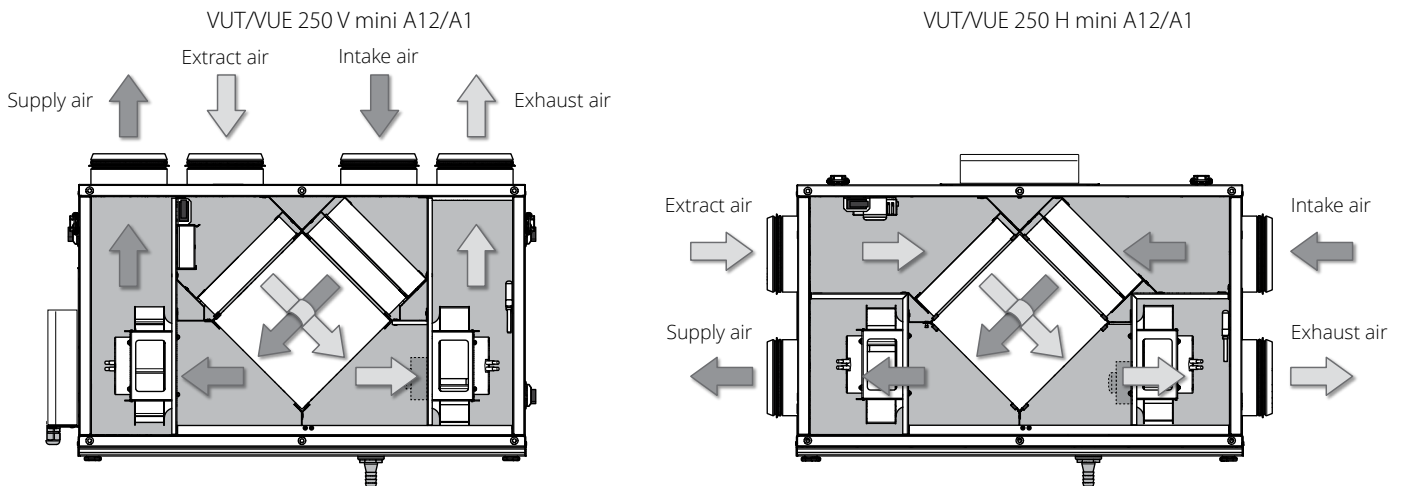

Freeze protection

The heat exchanger freeze protection function of the unit is implemented with a temperature sensor or a thermostat depending on model. The temperature sensor is installed in the exhaust air duct downstream of the heat exchanger. In case of a freezing danger (extract air temperature downstream of the heat exchanger is $+3\text{ }^{\circ}\text{C}$) the supply fan is turned off and the heat exchanger is warmed up with warm extract air flow. To set the thermostat temperature set point set the temperature control knob into a respective position.

UNIT DESIGN

VUT/VUE 250 V mini A12/A1

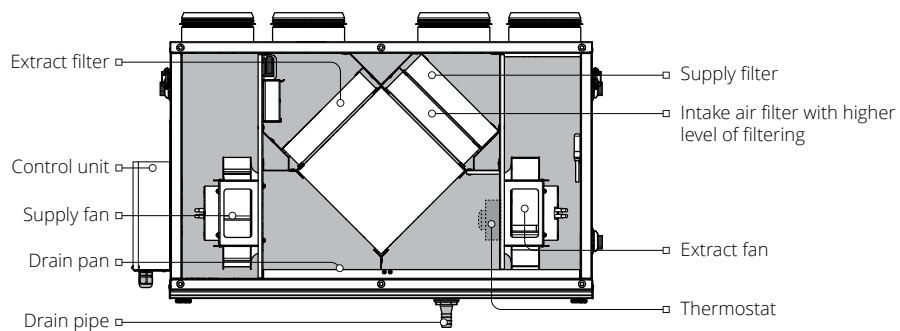

VUT/VUE 250 H mini A12/A1

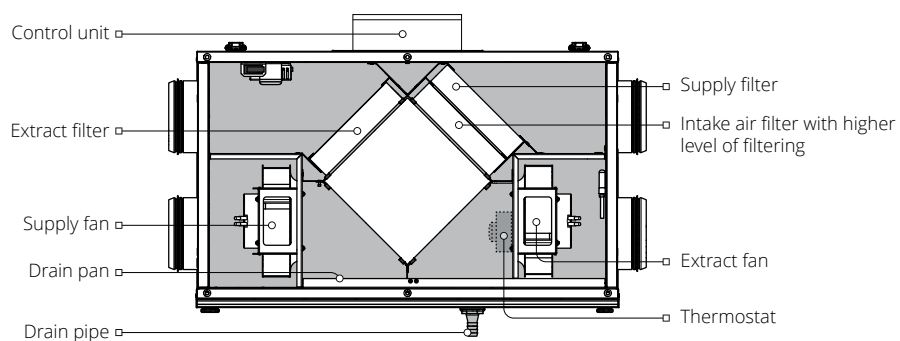

INSTALLATION AND SET-UP



READ THE USER'S MANUAL BEFORE INSTALLING THE UNIT.



THE UNIT MUST BE MOUNTED BY A QUALIFIED EXPERT ONLY, PROPERLY TRAINED AND HAVING THE REQUIRED TOOLS AND MATERIALS.

While installing the unit, provide enough access for maintenance or repair work.

When selecting an installation location of the unit, provide free opening of the service panel.

To get the best performance of the unit and to minimize turbulence-induced air pressure losses, connect the straight air duct section to the spigots on both sides of the unit while installing.

Minimum straight air duct length:

- equal to 1 air duct diameter on intake side
- equal to 3 air duct diameters on outlet side

If the air ducts are too short or not connected, protect the unit parts from ingress of foreign objects.

To prevent uncontrollable access to the fans, the spigots may be covered with a protecting grille or other protecting device with mesh width not more than 12.5 mm.

The unit must be mounted on a plane wall.

Installing the unit to an uneven surface could lead to the unit's casing distortion and operation disturbance.

The unit is designed for mounting on a horizontal plane as well as for wall mounting with a fixing bracket that is fastened with three screws and dowels (not included in the delivery set).

UNIT WALL MOUNTING

1. When selecting the installation site, provide minimum allowed distances to the unit.

VUT/VUE 250 V mini A12/A1

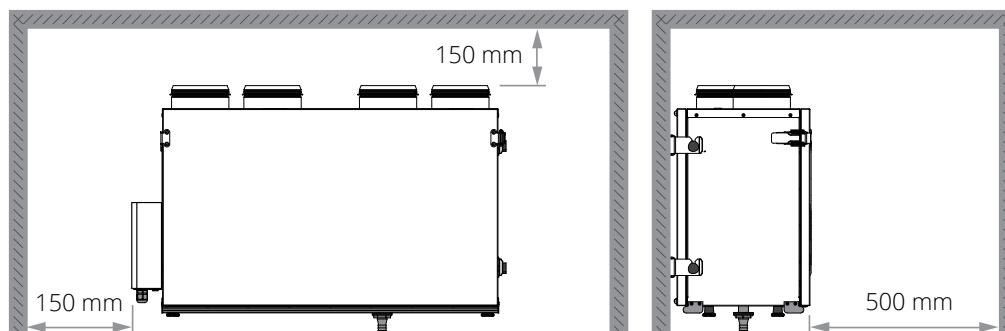

VUT/VUE 250 H mini A12/A1

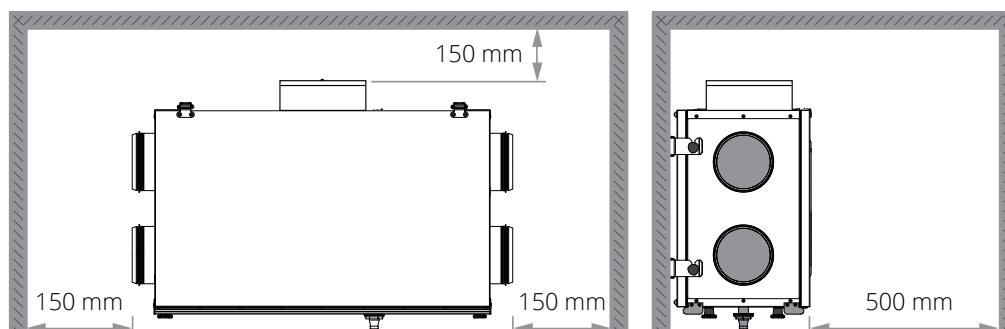

2. Attach the wall mounting brackets to a wall or to a ceiling considering the wall material and the unit weight.

WARNING! Ceiling mounting is only available for the units with a polymerized cellulose heat exchanger.

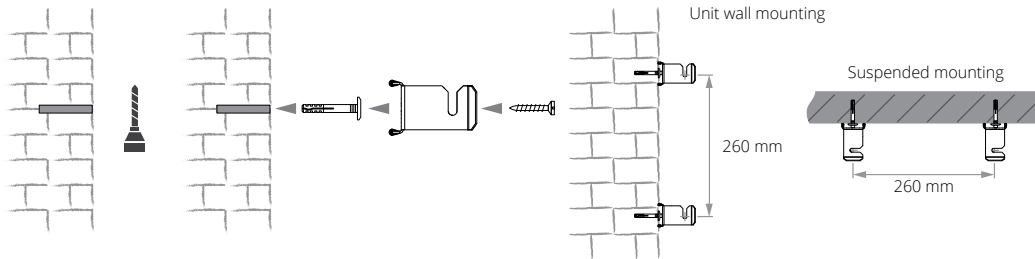

3. Install the unit on the mounting brackets. Tighten the triangular fixing screws on the mounting brackets.

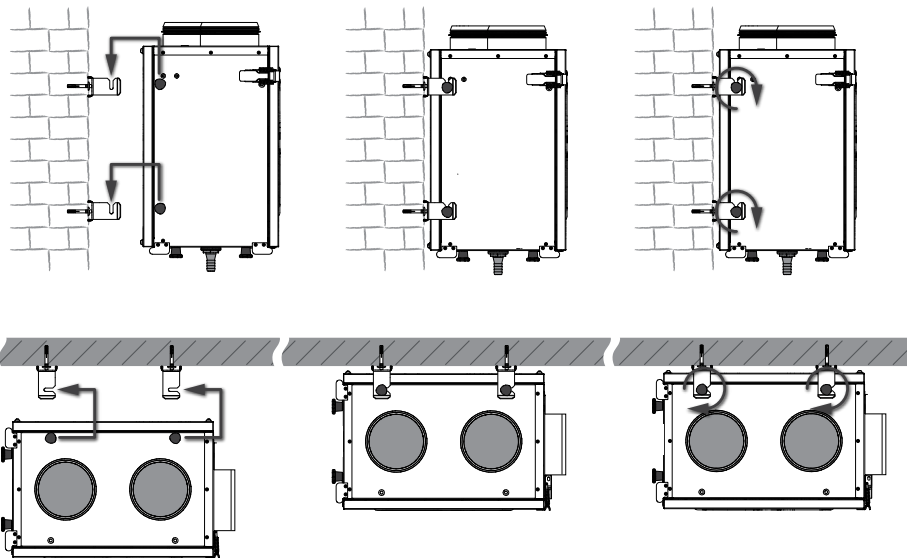

SUSPENDED MOUNTING USING L-SHAPED BRACKETS (only for VUE models)

When using the L-shaped brackets, the unit can be mounted close to the ceiling or on the threaded rods.

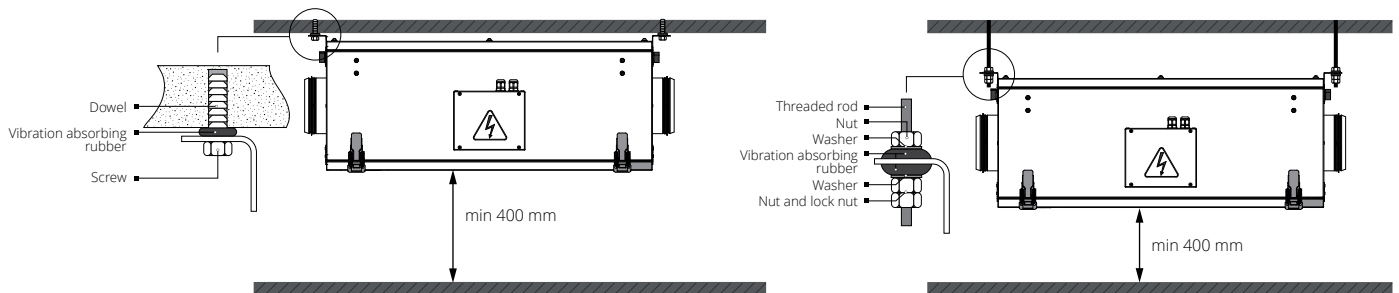

UNIT FLOOR MOUNTING

Install the unit on the pre-mounted floor supports, minimum 150 mm height, to ensure sufficient access for the drain pipe connection to the U-trap and for condensate drain system installation.

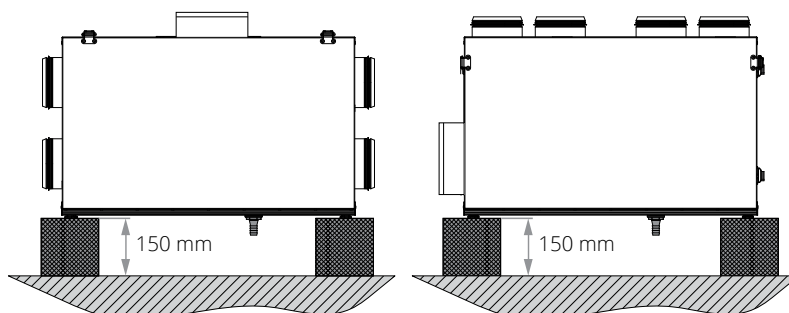

SERVICE SIDE CHANGE

Make sure of the correct unit service side selection. Unit mounting position should enable free access to the service panel for maintenance and service operations.

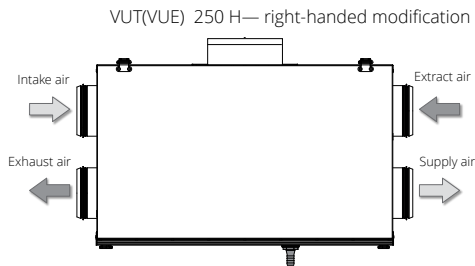
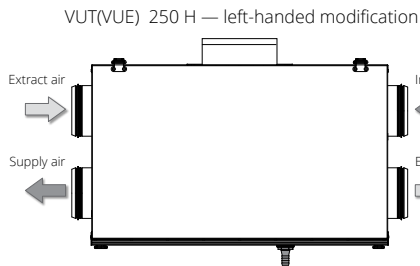
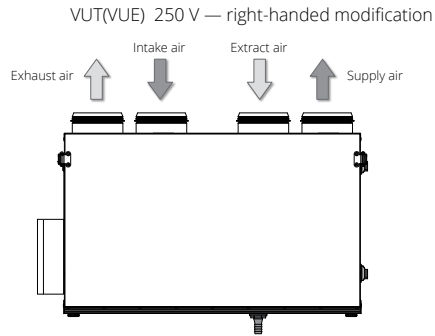
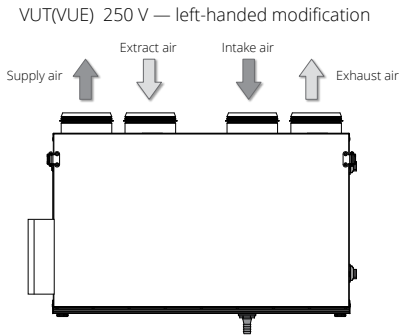

1. Unlatch and open the service panel. Remove the service panel, and then remove the latches. Disconnect the limit switch and remove it from the opening in the holder.

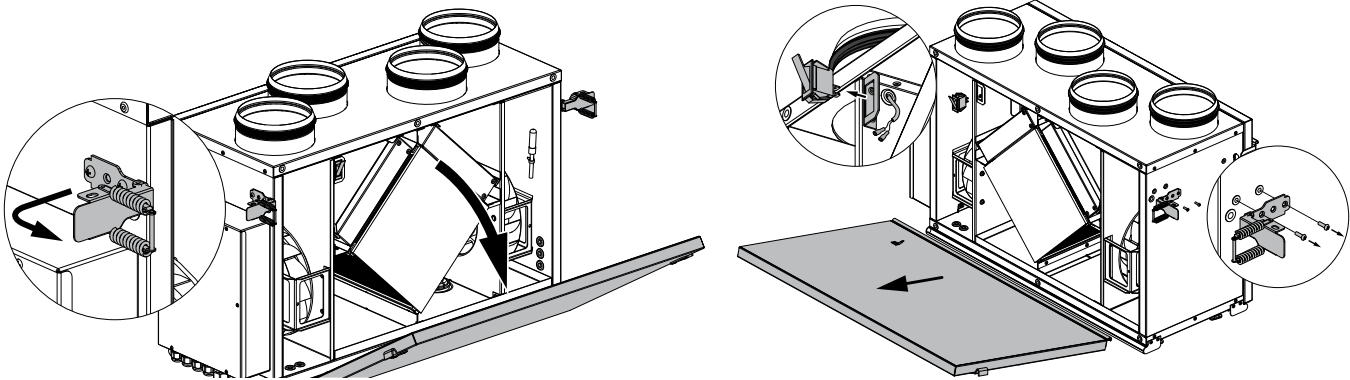

2. Remove four triangular screws and suspend the suspension brackets. Then unscrew six fixing screws from the back panel and remove the panel. Install the back panel on the opposite side of the unit.

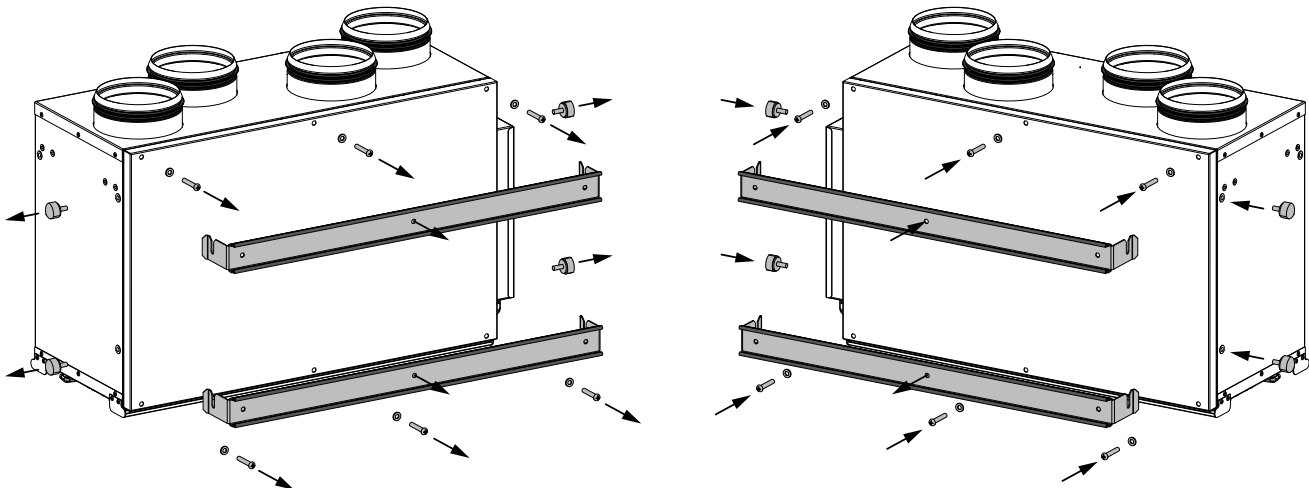

3. Install the limit switch, the latches and the service panel on the opposite side of the unit.

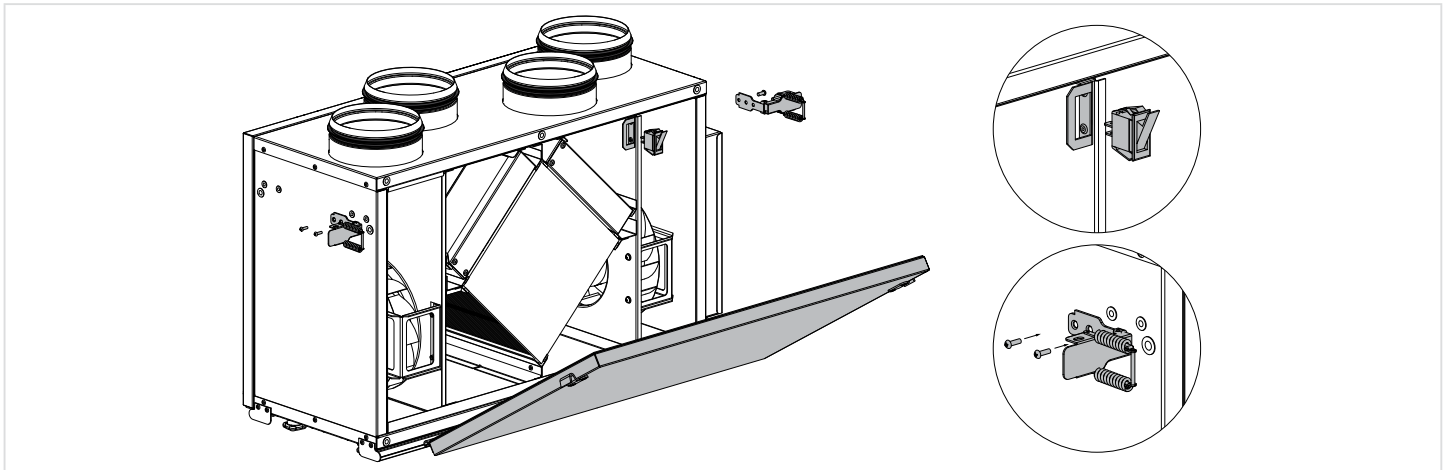

Service side change is shown by the example of the VUT/VUE 250 V mini A12/A1 air handling unit.
The procedure of the service side changing for VUT/VUE 250 H mini A12/A1 is carried out in the same manner.

CONDENSATE DRAINAGE SYSTEM CONNECTION (ONLY FOR THE VUT 250 V/H mini A12/A1 MODEL)

The VUE 250 V/H mini A12/A1 units are equipped with an enthalpy heat exchanger and don't require condensate drainage.
The hole for the drain pipe is at the bottom of the unit. Remove the plug from the hole, open the service panel and install the drain pipe from the delivery set into the hole, then connect the drain pipe to the sewage system using the SG-32 U-trap kit (available upon separate order). The pipe slope downwards must be at least 3°.

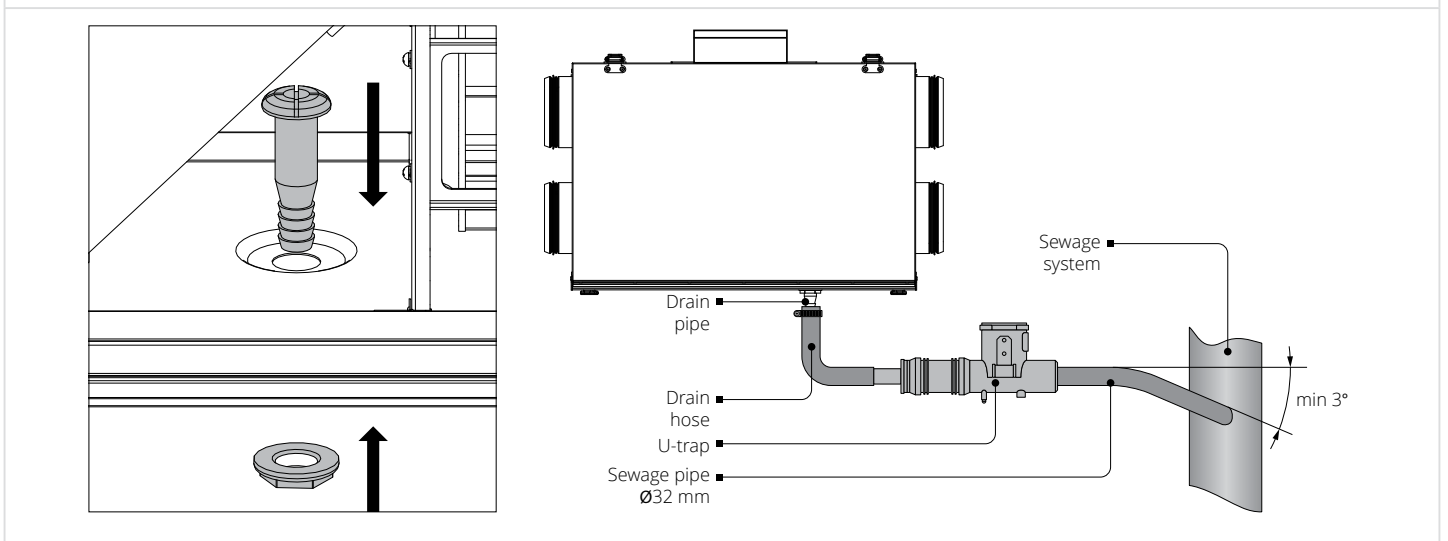

A1 SPEED CONTROLLER INSTALLATION

1. Disconnect the front panel from the speed controller:
 - Remove the control knob.
 - Remove the retaining nut that fixes the front panel.
 - Remove the speed controller front panel.

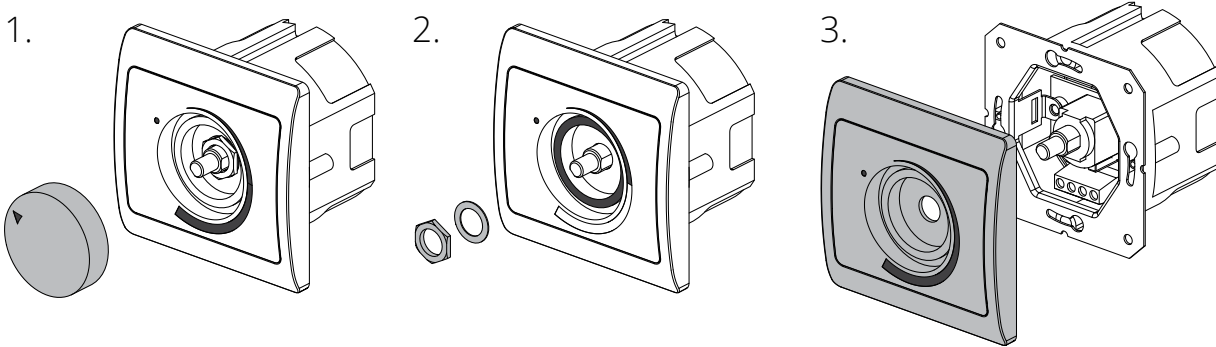

2. Loosen the two screws to disconnect the mounting box from the speed controller. Disconnect the control cable from the speed controller. Remember the colour marking of the wires and the terminals to enable their correct connection after completing of the speed controller mounting.

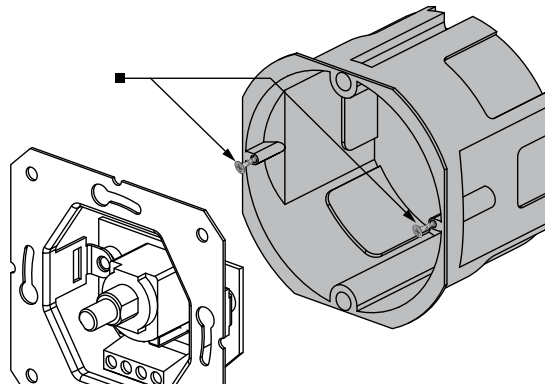

3. Insert the mounting box in the wall. The cable from the delivery set may be replaced with a cable of required length, type 3x0.5 mm² and max. length of 10 m.

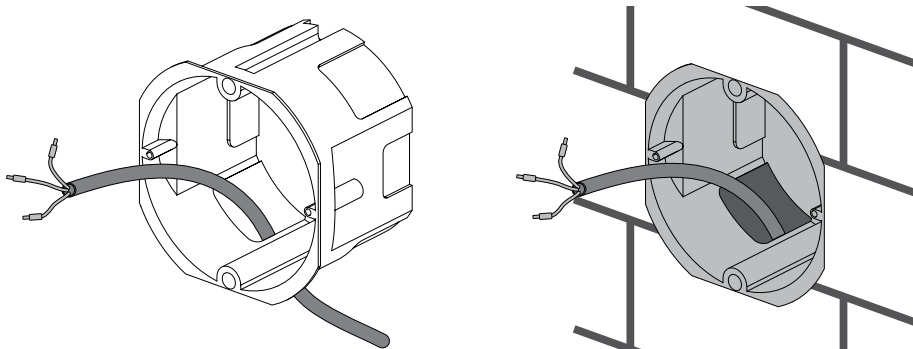

4. Connect the cable to the speed controller following the wiring diagram on page 15. Install the speed controller inside the mounting box using screws.

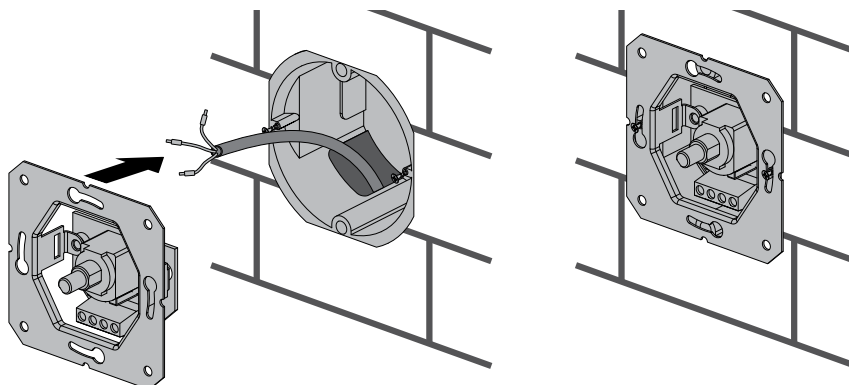

5. Mount the speed controller front part:
- Install the speed controller front panel.
 - Fix the front panel with a washer and a nut.
 - Install the control knob.
 - The speed controller mounting is completed.

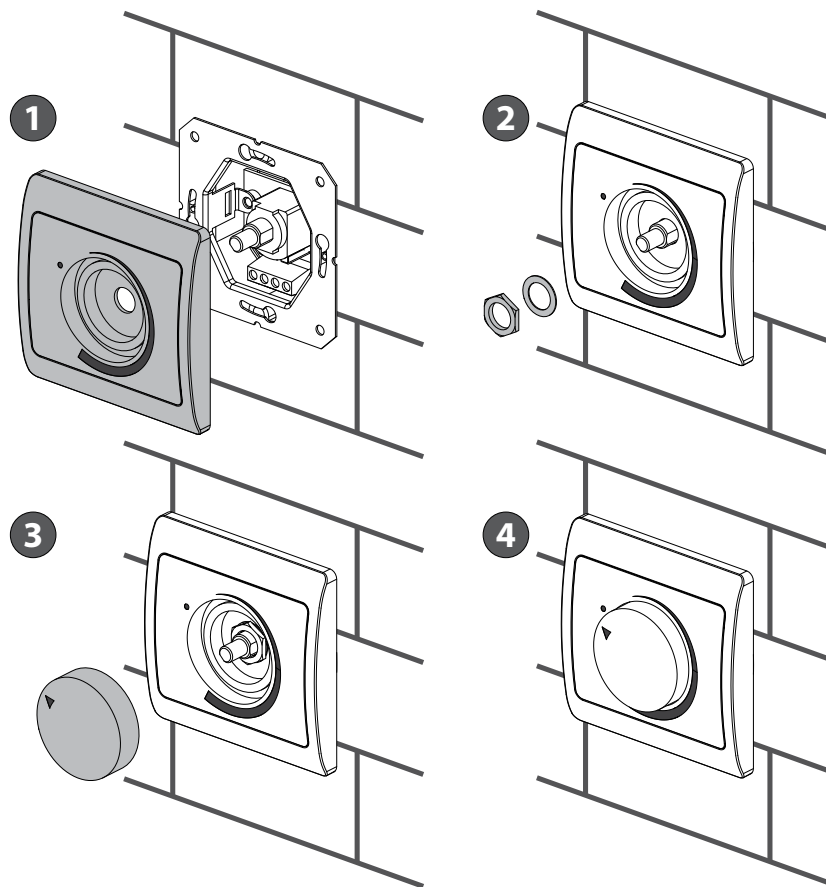

A12 SENSOR SPEED CONTROLLER MOUNTING

CAUTION!

Makes sure that the speed controller is intact. Do not use damaged speed controllers. Do not mount the speed controller onto an uneven surface. While tightening the self-tapping screws do not apply excessive force to prevent speed controller casing deformation.

The sensor speed controller is installed as follows:

- Use a screwdriver to carefully undo the clips of the speed controller front panel.
- Remove the back panel.
- Route the cable in the wall to the panel installation site.
- Attach the back panel on the wall or in the mounting box through the mounting holes.
- To install the speed controller front panel clip it in place.

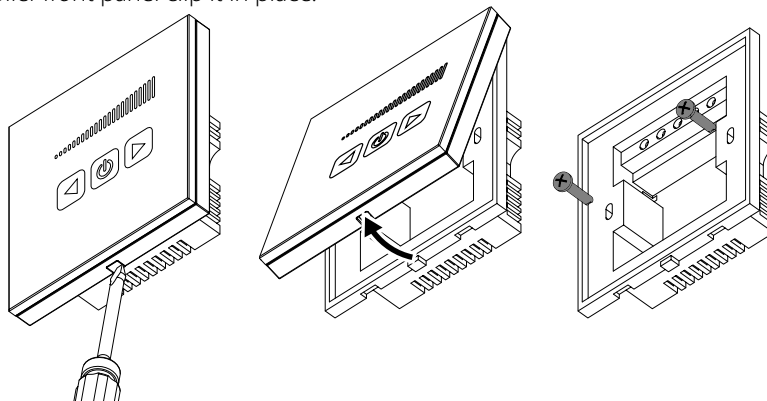

CONNECTION TO POWER MAINS



DISCONNECT THE UNIT FROM POWER MAINS PRIOR TO ANY OPERATIONS. THE UNIT MUST BE CONNECTED TO POWER MAINS BY A QUALIFIED ELECTRICIAN. THE RATED ELECTRICAL PARAMETERS OF THE UNIT ARE GIVEN ON THE MANUFACTURER'S LABEL.



DO NOT LAY THE CABLE IN CLOSE PROXIMITY TO THE CONTROL PANEL CABLE! DO NOT COIL THE CABLE FROM THE CONTROL PANEL IN LOOPS WHILE LAYING IT.



ANY INTERNAL CONNECTION MODIFICATIONS ARE NOT ALLOWED AND RESULT IN WARRANTY LOSS.

Connect the unit to a single-phase AC 230 V/50 (60) Hz power mains by using the pre-wired power cord with the Euro Plug XP.

Connect the unit to power mains through the external automatic circuit breaker QF with a magnetic trip integrated into the fixed wiring system with the rated current not below the rated current consumption (refer to the «Technical data» section).

EXTERNAL CONNECTION DIAGRAM FOR THE A1 SPEED CONTROLLER

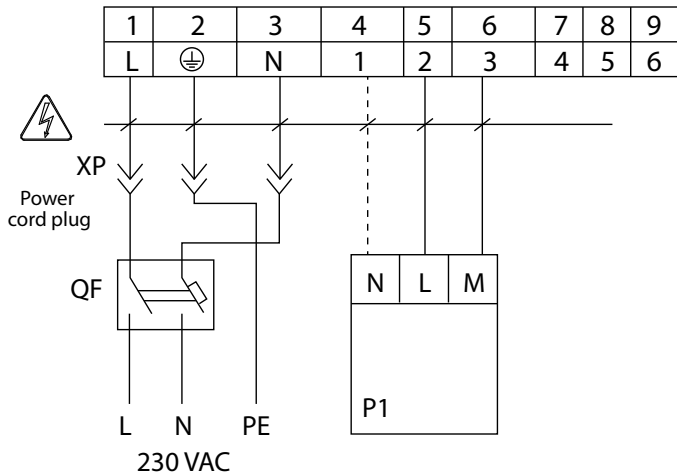

— Electric shock hazard!

Designation	Name	Cable type
P1	External control panel	2 x 0.75 mm ² (3 x 0.75 mm ²)

*Choose a cable depending on connection type

EXTERNAL CONNECTIONS DIAGRAM FOR THE A12 CONTROL PANEL

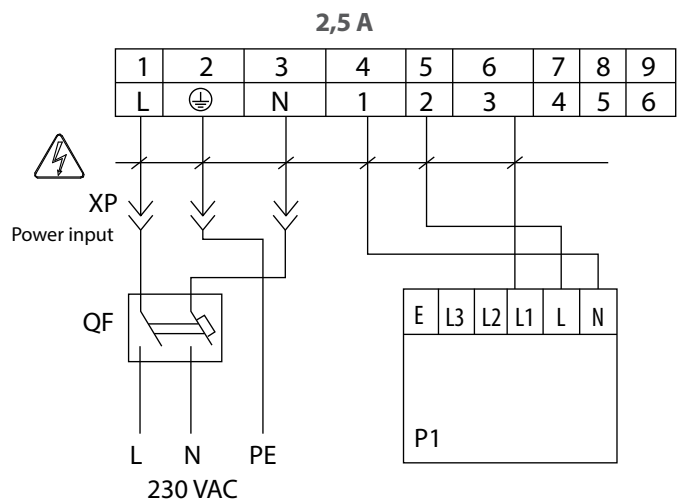
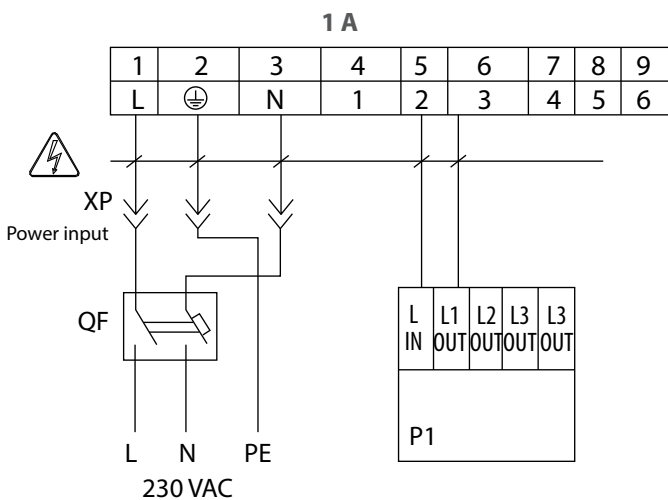

— Electric shock hazard!

Designation	Name	Cable type
P1	External control panel	2 x 0.75 mm ²



— Electric shock hazard!

Designation	Name	Cable type
P1	External control panel	2 x 0.75 mm ²

UNIT CONTROL





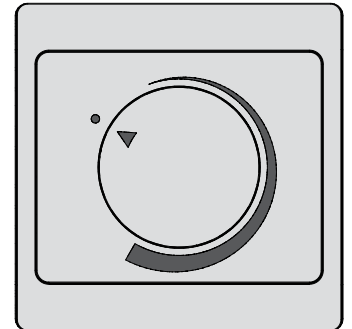





CONTROL OF THE UNIT WITH THE A1 AUTOMATION SYSTEM

Air flow is controlled with the RS-1/400 speed controller.
Set the control knob to a respective speed position to activate the required unit speed.
The speed controller view is shown below.



CONTROL OF THE UNIT WITH THE A12 AUTOMATION SYSTEM

The unit is operated from the sensor speed controller by using the touch buttons.

Operation	Button
When the system is powered on, the button lights up a faint blue.	
Press to switch on the unit.	
Press again to switch the unit off.	
Press to decrease the speed of the unit.	
Press to increase the speed of the unit.	
Setting the desired minimum speed is as follows:	
1. Press and hold the button for 5 seconds until the LED indicator reaches 50 % of its operating range (this helps differentiate the setup mode from the operation mode). Air flow is reduced to 50 %.	
2. Setting the desired minimum speed is as follows:	
Press repeatedly to increase the speed.	
Press repeatedly to decrease the speed.	
The set speed level is indicated by the LED display.	
Press to save the selected value.	
Press to switch on the fan and to activate its operation.	
When selecting the minimum value, the set value will be saved.	

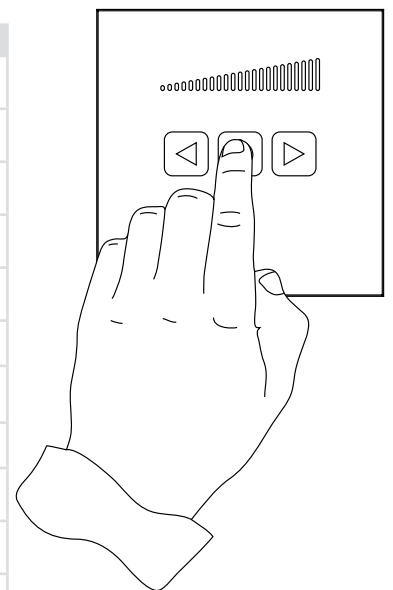

Speed controller control

TECHNICAL MAINTENANCE



DISCONNECT THE UNIT FROM POWER SUPPLY BEFORE ANY MAINTENANCE OPERATIONS!

Maintenance operations of the unit are required 3-4 times per year. It includes general cleaning of the unit and the following operations:

1. Filter maintenance (3-4 times per year).

Dirty filters increase air resistance in the system and reduce supply air volume. The filters require cleaning not less than 3-4 times per year. Vacuum cleaning is allowed. After two consecutive cleanings filters must be replaced. For new filters contact the Seller. The steps to replace the filters are as follows (refer to the figure on p. 16):

1. Press out on the latches.
2. Open the unit panel.
3. Remove the filters from the unit.

2. Fan maintenance (once per year).

Even in case of regular maintenance of the filters, some dust may accumulate inside the fans and reduce the fan performance and supply air flow. Clean the fans with a soft brush or cloth. Do not use water, aggressive solvents, or sharp objects as they may damage the impeller.

3. Heat exchanger maintenance (once per year).

Some dust may accumulate on the heat exchanger even in case of regular maintenance of the filters. To maintain the high heat recovery efficiency, regular cleaning is required. To clean the heat exchanger, pull it out, flush the heat exchanger with warm detergent solution. After cleaning install the dry heat exchanger back to the unit.

To remove the filters and the heat exchanger follow the operation operation in Fig. 16:

1. Release the latches and remove the bottom panel.
2. Open the unit panel.
3. Remove the heat exchanger.

4. Technical maintenance of condensate drainage system (once a year).

The condensate drainage (drain line) may get clogged by dirt and dust particles contained in the exhaust air. Check the drain line operation by filling the drain pan under the unit with water, clean the U-trap and the drain line, if necessary.

5. Supply air flow control (twice per year).

The supply duct grille may get clogged with leaves and other objects reducing the unit performance and supply air delivery. Check the supply grille twice per year and clean it as required.

6. Technical maintenance of air duct system (every 5 years).

Even regular fulfilling of all the prescribed above maintenance operations may not completely prevent dirt accumulation in the air ducts which reduces the unit capacity.

TECHNICAL MAINTENANCE

1.

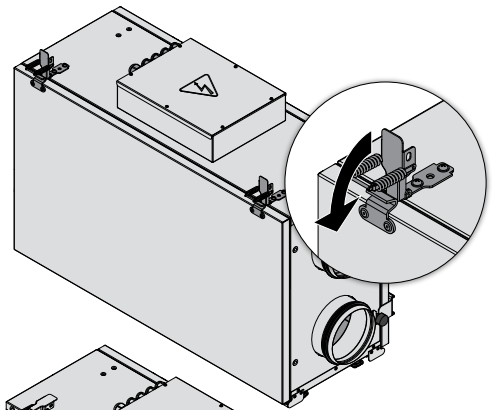
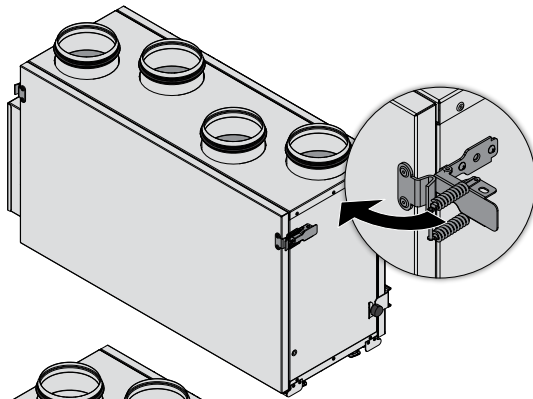

2.

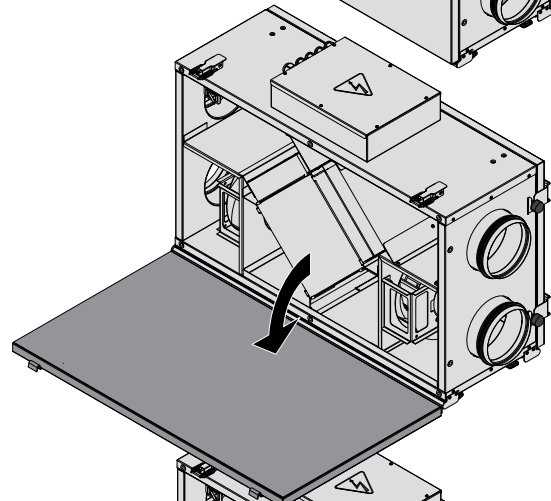
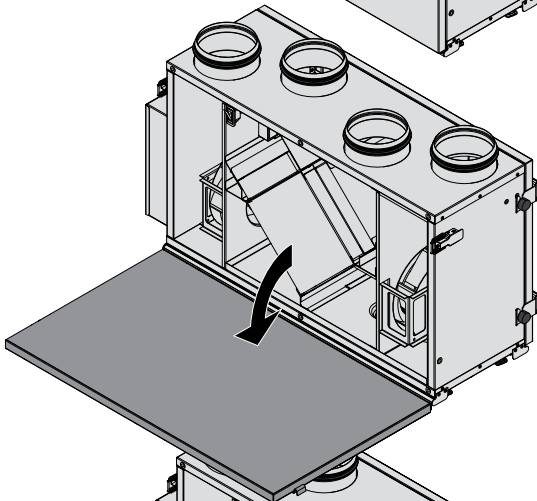

3.

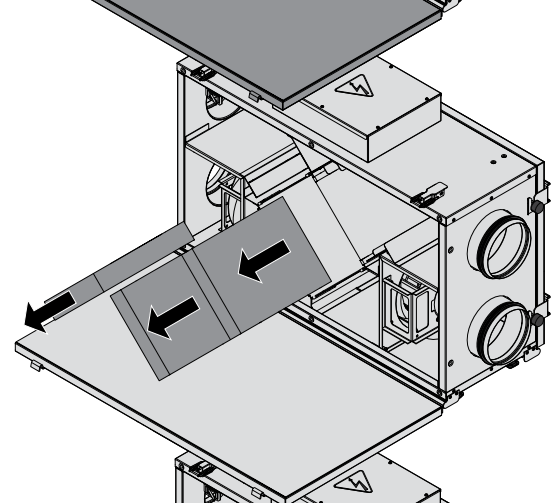
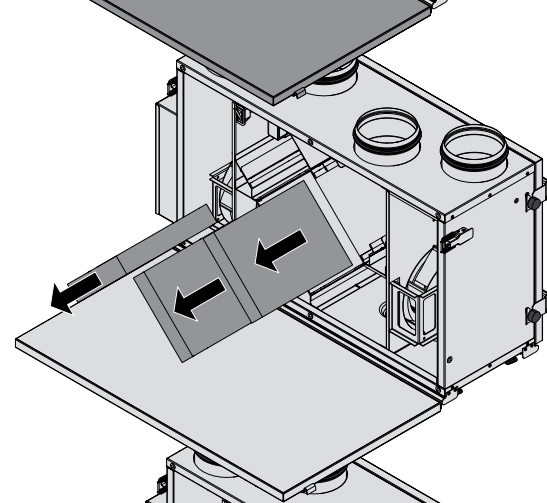

4.

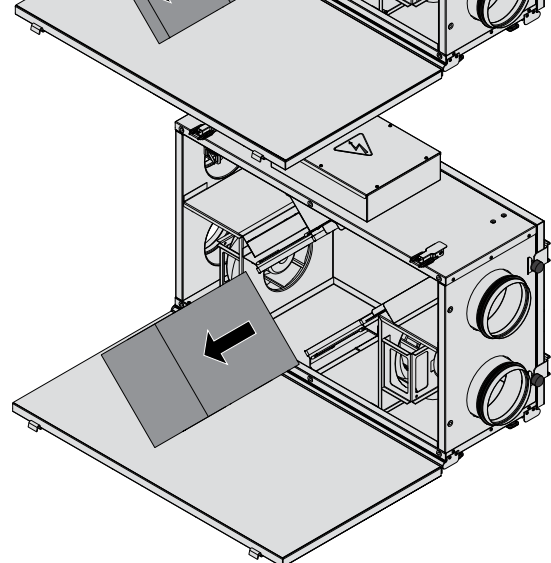
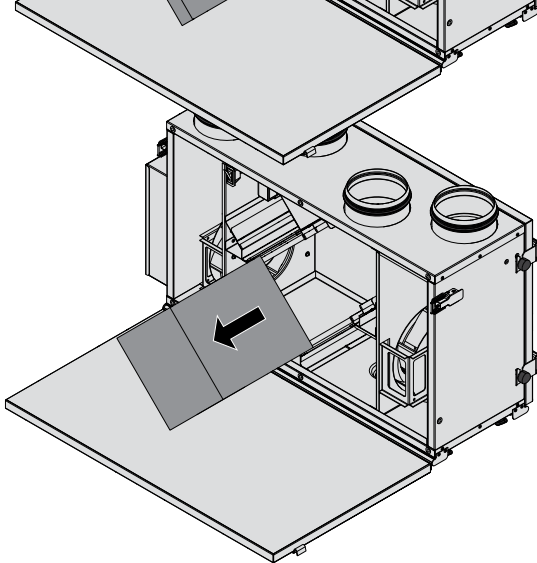

TROUBLESHOOTING

Problem	Possible reasons	Troubleshooting
The fan(s) do(es) not get started.	No power supply.	Make sure the power supply line is connected correctly, otherwise troubleshoot a connection error.
Cold supply air.	Extract filter clogging.	Clean or replace the extract filter.
	The heat exchanger is frosted.	Check the heat exchanger for icing. Switch the unit off if required and turn it on after the freezing danger is no longer imminent.
Low air flow.	Filters, fans or the heat exchanger are soiled.	Clean or replace the filters, clean the fans, and the heat exchanger.
	The ventilation system is soiled or damaged.	Clean the ventilation system components. Replace the damaged components.
Noise, vibration.	The fan impeller is soiled.	Clean the impellers.
	The fan or casing screw connection is loose.	Tighten the screw connection of the fans or the casing all the way.
Water leakage (only for the VUT 250 V/H mini A12/A1).	The drainage system is soiled, damaged or arranged not correctly.	Clean the drain line. Check the drain line slope angle. Make sure that the U-trap is filled with water and the drain pipes are frost protected.

STORAGE AND TRANSPORTATION REGULATIONS

- Store the unit in the manufacturer's original packaging box in a dry closed ventilated premise with temperature range from +5 °C up to +40 °C and relative humidity up to 70 %.
- Storage environment must not contain aggressive vapors and chemical mixtures provoking corrosion, insulation, and sealing deformation.
- Use suitable hoist machinery for handling and storage operations to prevent possible damage to the unit.
- Follow the handling requirements applicable for the particular type of cargo.
- The unit can be carried in the original packaging by any mode of transport provided proper protection against precipitation and mechanical damage. The unit must be transported only in the working position.
- Avoid sharp blows, scratches, or rough handling during loading and unloading.
- Prior to the initial power-up after transportation at low temperatures, allow the unit to warm up at operating temperature for at least 3-4 hours.

MANUFACTURER'S WARRANTY

The product is in compliance with EU norms and standards on low voltage guidelines and electromagnetic compatibility. We hereby declare that the product complies with the provisions of Electromagnetic Council Directive 2014/30/EU, Low Voltage Directive 2014/35/EU and CE-marking Directive 93/68/EEC. This certificate is issued following test carried out on samples of the product referred to above. The manufacturer hereby warrants normal operation of the unit for 24 months after the retail sale date provided the user's observance of the transportation, storage, installation, and operation regulations. Should any malfunctions occur in the course of the unit operation through the Manufacturer's fault during the guaranteed period of operation, the user is entitled to get all the faults eliminated by the manufacturer by means of warranty repair at the factory free of charge. The warranty repair includes work specific to elimination of faults in the unit operation to ensure its intended use by the user within the guaranteed period of operation. The faults are eliminated by means of replacement or repair of the unit components or a specific part of such unit component.

The warranty repair does not include:

- routine technical maintenance
- unit installation/dismantling
- unit setup

To benefit from warranty repair, the user must provide the unit, the user's manual with the purchase date stamp, and the payment paperwork certifying the purchase. The unit model must comply with the one stated in the user's manual. Contact the Seller for warranty service.

The manufacturer's warranty does not apply to the following cases:

- User's failure to submit the unit with the entire delivery package as stated in the user's manual including submission with missing component parts previously dismantled by the user.
- Mismatch of the unit model and the brand name with the information stated on the unit packaging and in the user's manual.
- User's failure to ensure timely technical maintenance of the unit.
- External damage to the unit casing (excluding external modifications as required for installation) and internal components caused by the user.
- Redesign or engineering changes to the unit.
- Replacement and use of any assemblies, parts and components not approved by the manufacturer.
- Unit misuse.
- Violation of the unit installation regulations by the user.
- Violation of the unit control regulations by the user.
- Unit connection to power mains with a voltage different from the one stated in the user's manual.
- Unit breakdown due to voltage surges in power mains.
- Discretionary repair of the unit by the user.
- Unit repair by any persons without the manufacturer's authorization.
- Expiration of the unit warranty period.
- Violation of the unit transportation regulations by the user.
- Violation of the unit storage regulations by the user.
- Wrongful actions against the unit committed by third parties.
- Unit breakdown due to circumstances of insuperable force (fire, flood, earthquake, war, hostilities of any kind, blockades).
- Missing seals if provided by the user's manual.
- Failure to submit the user's manual with the unit purchase date stamp.
- Missing payment paperwork certifying the unit purchase.



FOLLOWING THE REGULATIONS STIPULATED HEREIN WILL ENSURE A LONG AND TROUBLE-FREE OPERATION OF THE UNIT.



USER'S WARRANTY CLAIMS SHALL BE SUBJECT TO REVIEW ONLY UPON PRESENTATION OF THE UNIT, THE PAYMENT DOCUMENT AND THE USER'S MANUAL WITH THE PURCHASE DATE STAMP.

CERTIFICATE OF ACCEPTANCE

Unit Type	Heat recovery air handling unit
Model	_____250_____mini A_____
Serial Number	
Manufacture Date	
Quality Inspector's Stamp	

SELLER INFORMATION

Seller	
Address	
Phone Number	
E-mail	
Purchase Date	
This is to certify acceptance of the complete unit delivery with the user's manual. The warranty terms are acknowledged and accepted.	
Customer's Signature	

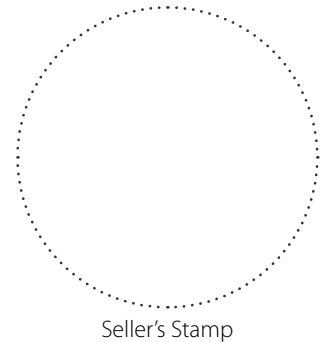

INSTALLATION CERTIFICATE

The _____250_____mini A_____ unit is installed pursuant to the requirements stated in the present user's manual.	
Seller	
Address	
Phone Number	
Installation Technician's Full Name	
Installation Date:	Signature:
The unit has been installed in accordance with the provisions of all the applicable local and national construction, electrical and technical codes and standards. The unit operates normally as intended by the manufacturer.	
Signature:	

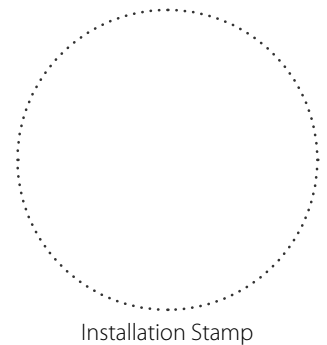

WARRANTY CARD

Unit Type	Heat recovery air handling unit
Model	_____250_____mini A_____
Serial Number	
Manufacture Date	
Purchase Date	
Warranty Period	
Seller	

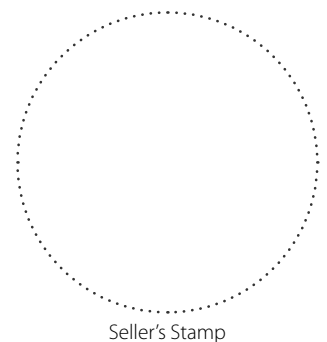



Μιχαήλ Καραολή 19, τκ 143 43, Ν. Χαλκηδόνα, Αθήνα
Τηλ: 211 - 70.55.500 & 210 - 21.30.051, Fax: 210 - 22.23.283

