



Commercial  
Systems

## Central vacuum units for the commercial sector

### Perfetto and Kompatta KT line

The three-phase Perfetto and Kompatta KT lines are the best solutions for cleaning complex structures (hotels, fitness centres, residences, homes for the elderly etc.). Aertecnica technology and innovation creates highly professional, new tools that guarantee effectiveness and faster, more flexible cleaning for large structures.

- *practicality*
- *easy to use*
- *energy savings*
- *low maintenance costs*
- *several operators at the same time*



## The advantages

- Its practicality and power, also in large buildings (e.g. hotels), recover the initial investment in a short period of time.
- It speeds up cleaning times, permitting two operators to work together in maximum silence and comfort.
- Maintenance costs are low, and savings in labour and consumable materials (bags and filters), make its cost a fraction of that for traditional portable vacuum cleaners.
- It is possible to equip the central power unit with a self-cleaning filter system, which reduces maintenance and guarantees improved suction.

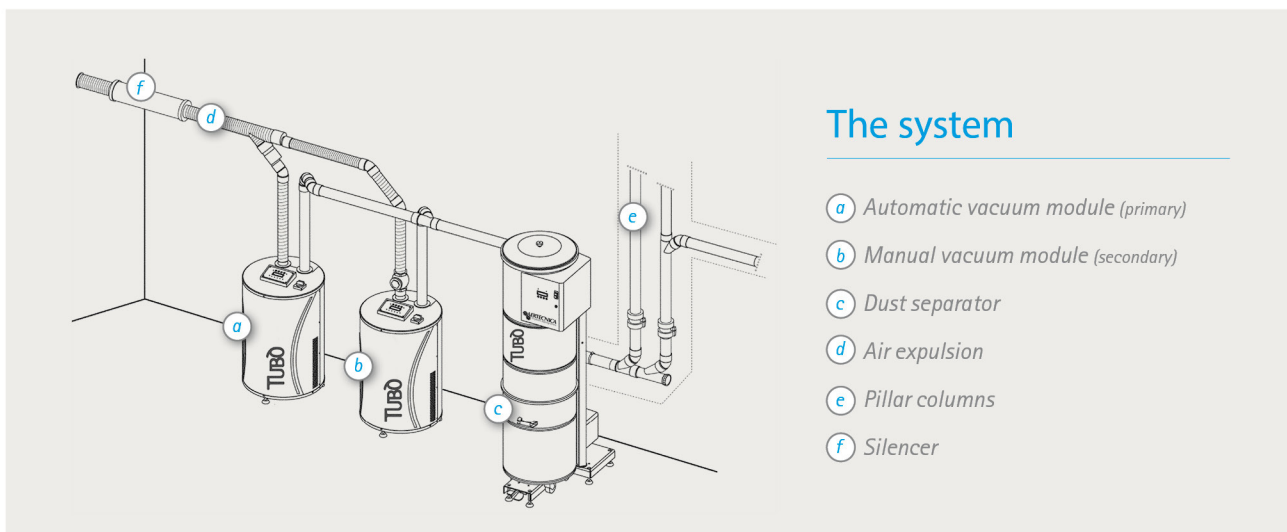



# The Perfetto line: intelligent technology



The technical features of the three-phase PERFETTO line emphasise its advantages in terms of practicality, simplicity of use, energy savings and reduced maintenance costs.

Consisting of a Vacuum Module and a Dust Separator, which is connected to it. The three-phase PERFETTO line makes it possible for 14 operators to work at the same time thanks to greater suction capacity.

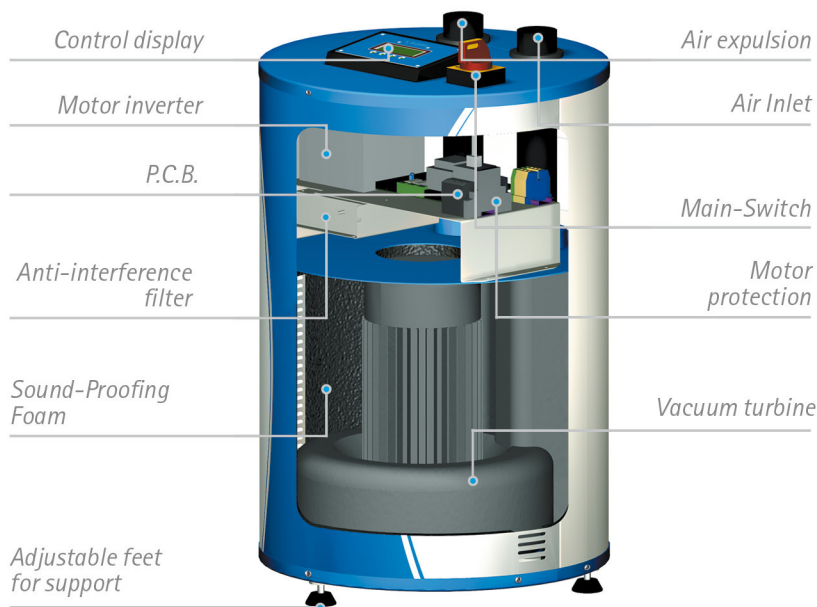

## Vacuum module display

The electronic component on the vacuum modules makes it possible to set and view operating parameters using a display screen.



In the event of central vacuum units with 2 or 3 vacuum modules, one of these modules must always be set to automatic vacuum regulation, and the remaining modules must be set to manual regulation.

All vacuum modules are sound-proofed and equipped with a display managed by an intelligent electronic circuit board, which monitors the machine status. In addition, the vacuum modules with automatic vacuum adjustment feature **SOFT START**, which guarantees lower energy consumption and a constant operating vacuum level.

The display on the vacuum module can display the following information:

- motor power uptake, in amperes
- the maximum time the vacuum module can remain in continuous use
- the hours of operation of the vacuum module
- the temperature of the motor chamber
- the operating vacuum in mbar

Differently from normal centralised vacuum systems, these vacuum motor modules can be connected to one another using the serial port provided, with no need for dedicated electrical panels. The status of the machine is shown on the displays of each module, as well as on the DYNAMIC CONTROL DISPLAY (optional extra code CMT800), which is installed in operating positions (reception, hallways, control areas, etc)

This set-up is necessary for proper system operation: the module equipped with automatic regulation will function as the primary motor and will automatically adjust the system's vacuum level until the set level is obtained.

Once the maximum efficiency percentage is obtained, the primary module will activate the secondary module with manual regulation via the serial connection, and will automatically adjust the system's vacuum level to bring it to the set level.



### VACUUM MODULES WITH AUTOMATIC VACUUM REGULATION\*

Code	Model	Description
CI406	M20ES	2.6Kw 230V single-phase
CI416	T20ES	2.2Kw 380V three-phase
CI426	T30ES	4.2Kw 380V three-phase
CI436	T40ES	6.3Kw 380V three-phase
CI446	T60ES	8.7Kw 380V three-phase

### VACUUM MODULES WITH MANUAL VACUUM REGULATION

Code	Model	Description
CI411	TR10S	2.2Kw 380V three-phase
CI421	TR20S	4.0Kw 380V three-phase
CI431	TR30S	5.5Kw 380V three-phase
CI441	TR40S	7.5Kw 380V three-phase

\* Sound-proofed modules with built-in electrical panel and display. Version with inverter

## The Perfetto line: vacuum modules

PERFETTO VACUUM MODULES		VACUUM MODULES WITH AUTOMATIC VACUUM REGULATION					VACUUM MODULES WITH MANUAL VACUUM REGULATION			
Code		CI406	CI416	CI426	CI436	CI446	CI411	CI421	CI431	CI441
Model		M20ES	T20ES	T30ES	T40ES	T60ES	TR10S	TR20S	TR30S	TR40S
Technical specifications										
No. of operators at the same time	n°	2	2	3	4	6	1	2	3	4
Power supply	Volts	230	380	380	380	380	380	380	380	380
Motor power	W	2.600	2.600	4.600	6.300	8.700	2.200	4.000	5.500	7.500
Motor rpm	rpm	3.500	3.500	3.500	3.500	3.500	2.900	2.900	2.900	2.900
Soft Start		YES	YES	YES	YES	YES	NO	NO	NO	NO
Inverter		YES	YES	YES	YES	YES	NO	NO	NO	NO
System vacuum regulation		AUT.	AUT.	AUT.	AUT.	AUT.	MAN.	MAN.	MAN.	MAN.
Socket power supply voltage	Volts	12	12	12	12	12	12	12	12	12
Air flow rate	m³/h	360	360	650	810	950	300	540	670	780
Vacuum	mbar	392	392	441	490	490	392	441	441	490
Height (H)	cm	78	78	95	95	95	78	95	95	95
Diameter (Ø)	cm	52	52	66	66	66	52	66	66	66
Weight	kg	48	48	73	86	95	46	71	85	93
Serial Connection for Control Display		YES	YES	YES	YES	YES	YES	YES	YES	YES
Noise level	dB	<70	<70	<70	<73	<74	<70	<70	<70	<70
Air inlet/outlet diameter	mm	63/63	63/63	80/80	100/100	100/100	63/63	80/80	100/100	100/100





# The Perfetto line: separators

## SUMMARY TABLE OF PERFETTO DUST SEPARATORS

Code		CI090	CI150	CI090A	CI150A
Model		LT 90/B	LT 150/B	LT 90/B-AP	LT 150/B-AP
Technical specifications					
Automatic filter cleaning system power supply	Volts	NO	NO	230	230
Filter cartridge surface area	cm <sup>2</sup>	50.000	73.000	50.000	73.000
Filter cartridge material		polyester	polyester	polyester	polyester
Dust container capacity	litres	90	150	90	150
Automatic filter cleaning system operating pressure	bar	NO	NO	3,8	3,8
Automatic filter cleaning system reservoir capacity	litres	NO	NO	9	9
Dimensions (WxDxH)	cm	58x85x175	58x85x175	58x85x175	58x85x175
Weight	kg	70	96	88	110
Noise level	dB	<70	<70	<70	<70
Suction outlet height	cm	150	150	150	150
Suction inlet height	cm	87	87	87	87
Air inlet/outlet diameter	mm	80/80*	100/100*	80/80*	100/100*

\* The air expulsion and inlet vents are reversible (right or left)

*Three-phase Perfetto line separators (from 90 to 150 litres) complete structure of the central vacuum unit. They are equipped with a protection system that prevents excessive pressure values and protects the motor using a compensation valve.*

Code	Model
CI090	LT90/B
CI090A	LT90/B with self-cleaning function
CI150	LT150/B
CI150A	LT150/B with self-cleaning function

Available with or without the self-cleaning system, they also include displays showing the following parameters:

- dust container filling percentage
- filter cartridge saturation percentage
- compressor cylinder pressure during self-cleaning stage
- operating vacuum in mbar



The version with self-cleaning filters also allows you to program filter self-cleaning cycles with a timer, based on how saturated the filter is.

All three-phase Perfetto line separators have a dust container opening/closing system which, thanks to two pedals at the base of the machine, facilitates emptying and maintenance operations.

## Version with self-cleaning system

### Components

- |                                       |   |
|---------------------------------------|---|
| 1. Reversible air outlet              | 9. Main switch                                      |
| 2. Compressed air cylinder            | 10. Built-in compensation valve                     |
| 3. Reversible air inlet               | 11. Condensate drain                                |
| 4. Bag full sensor                    | 12. Polyester filter cartridge                      |
| 5. Air cylinder recharging compressor | 13. Dust collection bag                             |
| 6. Bag tensioner                      | 14. Hydraulic dust container opening/closing device |
| 7. Adjustable support feet            |   |
| 8. Control display                    |   |

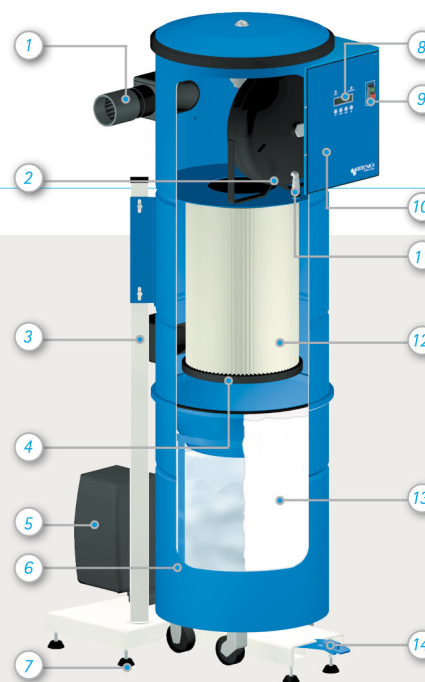



## Kompatta KT line

The KT line is based on a "PLUG & PLAY" system; this is why it offers our installation technician the guarantee of total reliability and really fast installation, as well as drastically reducing the amount of occupied space.



The three-phase Kompatta KT line was created to satisfy the needs of the service and professional sectors.

Its versatility and highly efficient technical features, designed to make it easier to use, offer solutions targeted towards the needs of an increasingly demanding and evolved market. The machine consists of a single structure divided into three sections:

- Upper section: motor housing.
- Central section: dust filter.
- Lower section: cyclone and storage of the vacuumed material.

*The main features of this product are:*

- A wide line of 8 different models.
- From one to three operators at the same time.
- Dust filter.
- Dust filter, with a self-cleaning system.
- Mechanical vacuum regulation.
- Electronic vacuum regulation.
- Electrical panel built into the machine body.
- Built-in and sound-proofed compensation valve.

*Kompatta KT central vacuum unit*

Code	Model	Description
CIKT20M	KT20M	2.6Kw 230V single-phase
CIKT10	KT10	2.2Kw 380V three-phase
CIKT20	KT20	2.2Kw 380V three-phase
CIKT30	KT30	4.2Kw 380V three-phase

Particular attention was placed on guaranteeing silent operation: the use of composite and polyurethane-based materials and the insertion of anti-vibration systems on dynamic parts has considerably reduced the noise level and improved performance and efficiency, bringing them well above standard.

The filter cartridge, made entirely from WASHABLE polyester, has a filtering surface area of approximately 5 m<sup>2</sup>. The self-cleaning system provides for optimal machine operation, limiting pressure drops caused by dirty filter cartridges. The large capacity of the dust container (150 litres), reduces maintenance operations (container emptying).

*The Kompatta KT line was designed for our installation technician.*

PLUG & PLAY technology simplifies connection to the system's central vacuum unit: the single unit structure is equipped with quick electric connectors and terminals included in the installation set, eliminating any errors when making the electrical connections.

*Kompatta KT central vacuum unit with self-cleaning system*

Code	Model	Description
CIKT20MA	KT20MA	2.6Kw 230V single-phase
CIKT10A	KT10A	2.2Kw 380V three-phase
CIKT20A	KT20A	2.2Kw 380V three-phase
CIKT30A	KT30A	4.2Kw 380V three-phase





## Technical table for Kompatta KT line

Code	Unit of measurement	CIKT10	CIKT10A	CIKT20	CIKT20A	CIKT20M	CIKT20MA	CIKT30	CIKT30A
No. of operators at the same time	n°	1	1	2	2	2	2	3	3
Self-cleaning		NO	YES	NO	YES	NO	YES	NO	YES
Power supply	Volts	380	380	380	380	230	230	380	380
Motor power	W	2.200	2.200	2.600	2.600	2.600	2.600	4.600	4.600
Motor rpm	rpm	2.900	2.900	3.500	3.500	3.500	3.500	3.500	3.500
Socket power supply voltage	Volts	12	12	12	12	12	12	12	12
Air flow rate	m³/h	300	300	360	360	360	360	650	650
Max. vacuum	mbar	392	392	392	392	392	392	491	491
Dimensions	WxDxH	92x76x196	92x76x196	92x76x196	92x76x196	92x76x196	92x76x196	92x76x196	92x76x196
Weight	kg	132	150	132	150	132	150	152	170
Diameter	Ø (cm)	56	56	56	56	56	56	56	56
Noise level	dB	<70	<70	<70	<70	<70	<70	<70	<70
Filter cartridge surface area	cm²	50.000	50.000	50.000	50.000	50.000	50.000	50.000	50.000
Filter cartridge material		POLYESTER	POLYESTER	POLYESTER	POLYESTER	POLYESTER	POLYESTER	POLYESTER	POLYESTER
Container capacity	l	150	150	150	150	150	150	150	150
Air inlet/outlet diameter	mm	80/80*	80/80*	80/80*	80/80*	80/80*	80/80*	80/80*	80/80*

\* The air expulsion and inlet vents are reversible (right or left)

## Version with self-cleaning system

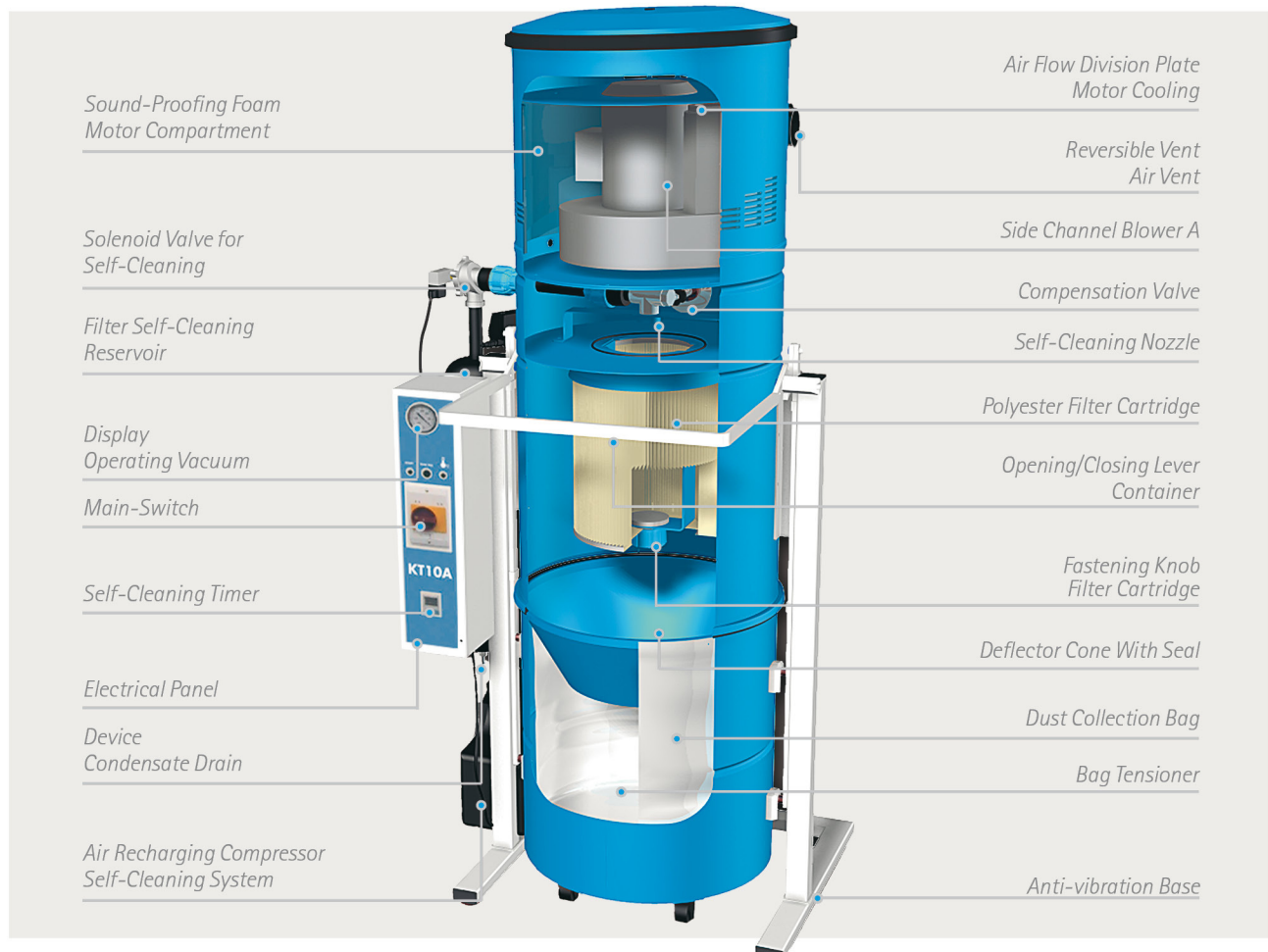

## Dynamic Control Display : Total control, at a distance



For PERFETTO three-phase central vacuum units for the TUBO system (optional)

This is an electronic device that is positioned in an area other than where the central vacuum unit is installed (e.g. reception, hall, etc...), and is used to automatically reset the system without having to access the machine in the event of a detected anomaly.

The Dynamic Control Display requires an auxiliary 12 Vdc power supply.

It shows:

- correct central vacuum unit operation
- the presence of system faults and blocks
- the temperature of the vacuum turbine
- the operating vacuum

Code	CMT800
Description	Dynamic Control Display Selecting TRbus mode allows you to use the Dynamic Control Display with the following central vacuum units exclusively: PERFETTO three-phase. Compatible with the electrical switch plates of the most prestigious brands available on the market. Electrical switch plate not included.

## Complementary accessories for three-phase central vacuum units



A silencer is essential in every central vacuum unit. It should be installed on the air expulsion pipe, near the grille: the type of silencer is chosen based on the diameter (Ø) of the expulsion pipe. A silencer with a diameter larger than the outlet diameter of the central vacuum unit is recommended for expulsion lines longer than 6 metres.

C1360	Metal silencer Ø 63 (Dimensions: height 50cm x Ø15)
C1365	Plastic silencer Ø 63 (Dimensions: height 36cm x Ø15)

C1380	Metal silencer Ø 80 (Dimensions: height 70cm x Ø17)
C1385	Plastic silencer Ø 80 (Dimensions: height 56cm x Ø15)

C1390	Metal silencer Ø 100 (Dimensions: height 70.5cm x Ø20)
C1397	Metal silencer Ø 160 (Dimensions: height 90.5cm x Ø22)



The check valve or non-return valve is a valve that allows the air in the vacuum system to flow in a single direction only.

C1561	Check valve for TR10S-M20ES-T20ES
C1581	Check valve for TR20S-T30ES
C1591	Check valve for TR30S-TR40S

N.B. The silencers and check valves for the three-phase central vacuum units are supplied complete with rubber sleeve and metal clamps for connection





# TUBO | X-PERT RT



1985 - 2015





# TUBO | X-PERT RT





# TUBÒ | X-PERT RT

Increased power,  
smaller in size.

Medium- and large-sized buildings have special needs regarding the installation and use of a central vacuum system: more power, contemporary design and small size.

The X-PERT RT central vacuum unit is the result of the desire to create an even more versatile product, to be used for both residential and service sector applications.

A single range able to meet the needs of an informed and demanding market, which only Aertecnica quality is able to satisfy.

*The Tubò system has solutions for every sector, from residential to commercial.*



# TUBO | X-PERT RT

It provides aspiration everywhere.

X-PERT RT is the new range of central vacuum units by Aertecnica, created to offer an even broader and more versatile line of products.

X-PERT RT is designed to be used as an alternative to the conventional range for residential applications where higher levels of performance and power are required.

X-PERT RT is used in the residential advanced or tertiary sector. X-PERT RT offers the same features as central vacuum units designed for the service sector, but with the compact size and pleasant appearance of residential sector units.

X-PERT RT offers excellent levels of performance and is built in compliance with Aertecnica's quality standards.

X-PERT RT is therefore the product bridging the gap between the residential and tertiary sectors, capable of adapting to different needs and will be used in: hotels, Bed & Breakfast, villas, gyms, offices, restaurants, clinics, etc., where at most 2 simultaneous operators are required and the surfaces are not too extensive.

*Since it is such a versatile product, we always recommend that you seek advice from our technical Office, or one of our sales consultants for a safe and correct choice.*

X-PERT RT is a multifunctional range, suitable for demanding customers that choose and appreciate the quality of Aertecnica products.



Model	RT1A
Code	CIRT10A
Description	2.2 kW 380V three-phase with standard APF system*
Operators	1

Model	RT2MA
Code	CIRT20MA
Description	2.6 kW 230V SINGLE PHASE with standard APF system*
Operators	1-2

Model	RT2A
Code	CIRT20A
Description	2.6 kW 380V three-phase with standard APF system*
Operators	1-2

\*In the event that the vacuum system is activated during the scheduled filter self-cleaning cycle (APFSystem), the central vacuum unit restart time will be approximately 30 seconds. APFSystem, Filter Self-Cleaning System, patented (Europe Patent Pending no. 06793421.6)





## X-PERT RT technical table

Model		RT1A	RT2MA	RT2A
Trade code		CIRT10A	CIRT20MA	CIRT20A
No. of operators at the same time		1	2	2
Self-cleaning system (APF System)*		YES	Yes	YES
Inverter		NO	YES	YES
Power supply	Volt (V)	380 - 400	220 - 240	380 - 400
Motor power	Watts (W)	2,200	2,600	2,600
Frequency	Hz	50 - 60	50 - 60	50 - 60
Maximum absorption:	A	6.5	11.2	6.5
Motor rpm	rpm	2,900	3,500	3,500
SOFT START		No	YES	YES
Vacuum Sockets power supply voltage	Volt (V)	12	12	12
Air flow rate		300	360	360
Maximum vacuum	mbar	392	392	392
Filtering surface	cm <sup>2</sup>	20,000	20,000	20,000
Filter cartridge material		POLYESTER	POLYESTER	POLYESTER
Dust container capacity	litres	66	66	66
Dust inlet diameter	mm	80	80	80
Air exhaustion diam.	mm	80	80	80
Vacuum Setting Adjustment	cm	Manual provided**	Electronic	Electronic
Height	cm	161***	161***	161***
Diameter	cm	46	46	46
Mass	kg	99	100	100
Noise	db	<70	<70	<70
Compatibility with CMT800 Panel (in Modbus mode)		YES	YES	YES

\* In the event that the vacuum system is activated during the scheduled filter self-cleaning cycle (APF System), the central vacuum unit restart time will be approximately 30 seconds.

\*\* Ø63 compensation valve provided

\*\*\* Check central vacuum unit installation dimensions in the technical manual

# TUBO | X-PERT RT



## Main features

- Installation and set-up system employing Plug & Play technology. Rapid connection is made possible thanks to the electrical connectors and terminals included in the installation set. This eliminates any possible errors with electrical connections.
- All models are provided complete with the APF filter self-cleaning System (a filter self-cleaning system patented by Aertecnica).
- Filter cartridge with large filtering surface area: 20,000 cm<sup>2</sup>, made from washable polyester.
- Electronic vacuum regulation: RT2A and RT2MA models only.
- Instant AVI display.
- Compensation Valve included: RT1A model only.
- Small size with high levels of performance.
- Ergonomic and easy-to-use dust container release handle.
- 66 Lt. Dust Container with "Quick Scroll" system with wheels





**TUBO**  
CENTRAL VACUUM SYSTEMS

## Ideal for:

X-PERT RT is the central vacuum unit which bridges the gap between the residential and tertiary sector. It can be installed in different kinds of structures:

- Hotels: even with a number of floors, when you decide to use one central vacuum unit on each floor.\*\*
- Bed & Breakfast\*
- Villas\*
- Gyms\*
- Offices\*
- Restaurants\*
- Clinics\*
- etc...

\* All these facilities must require a maximum of 2 operators working at the same time.

\*\* In the case of multi-storey Hotels, max. 2 operators working concurrently on the same floor.

Ideal fusion ... inside and out!

a

- Air expulsion
- Air flow division plate for motor cooling
- General on/off switch
- Electronic Card
- Temperature sensor
- Control Panel with AVI Display
- Inverter (only on RT2A - RT2MA models).  
Compensation valve for pressure adjustment only provided with model RT1A
- MODBUS communication system
- Side channel blower (Motor)

b

- APF System\*
- Washable polyester filter cartridge
- Left/right reversible dust inlet
- Filter cartridge fastening knob
- Handle for opening/closing of "Quick Scroll" dust container

c

- Deflector cone with seal
- Bag Tensioner
- Dust collection bag
- "Quick Scroll" dust container with wheels
- Anti-vibration base

\* In the event that the vacuum system is activated during the scheduled filter self-cleaning cycle (APF System), the central vacuum unit restart time will be approximately 30 seconds. APF System, Filter Self-Cleaning System, patented (Europe Patent Pending no. 06793421.6)





## The heart of the system

- 1 **Air expulsion**
- 2 **Electronic Card:** This circuit board is the heart of the whole system, it drives the motor start-up and the AVI display. A special programme communicates with the display, which uses icons and parameters to signal the operational state of the central vacuum unit.
- 3 **General on/off switch:** The on/off switch allows you to switch the central vacuum unit ON or OFF.
- 4 **Air flow division plate for motor cooling**
- 5 **Temperature sensor:** This monitors the operation of the central vacuum unit and intervenes in the event of malfunctions caused by incorrect usage.
- 6 **Side channel blower (Motor):** Protected, insulated and highly professional, this part ensures high performance and a long life for the central vacuum unit which will provide continuous work for a long time. 100% Italian technology.
- 7 **Control Panel with AVI Display:** (Instant view) Positioned on the front of the unit. It features state-of-the-art design, with icons and parameters that are very simple and easy to understand; the control panel also consists of a keypad for easy browsing and control of the various operating parameters of the central vacuum unit.
- 8 **Inverter (only on models RT2A-RT2MA) - Compensation Valve for pressure adjustment only provided with model RT1A.** The inverters on models for 2 operators (RT2A and RT2MA) and the compensation valve included on the RT1A model for 1 operator are the protection system for central vacuum units which avoids excessive pressure levels and protects the life of the motor.
- 9 **MODBUS communication system:** A generic ModBus protocol has been implemented in the central vacuum unit, which allows it to be interfaced with the most common home automation systems.



## Vacuum everywhere

- 10\* **APF System\***: The APF system (Self-cleaning filter) noticeably reduces filter maintenance, and allows the central vacuum unit to operate at optimal levels for longer, thanks to a filter that is always clean. APF System is an Aertecnica patent. And in the event that the vacuum system is activated during the scheduled filter self-cleaning cycle (APF System), the central vacuum unit restart time will be approximately 30 seconds.
- 11 **Washable polyester filter cartridge**: made of highly efficient filtering material which is washable. Equipped with an alignment system, which makes for easier installation and maintenance.
- 12 **Left/right reversible dust inlet**: a big plus for the installer. Ensures maximum flexibility of assembly of the central vacuum unit in every position, making installation faster.
- 13 **Handle for opening/closing of "Quick Scroll" dust container**: Practical and functional closing and opening system. An advantage for the user who will be able to easily move the dust container for easy and quick maintenance.

### \*APF System\*\*\* standard fitting on all models

The central power unit is equipped with a self-cleaning system (Aertecnica patent) which allows the dust removal through vibration filter. This extends the regeneration/ replacement time of the filter cartridge.

#### APF SELF-CLEANING ACTIVATION MODE

The daily self-cleaning process can be set according to one of the procedures below:

- 0 - APF disabled
- 1 - Activation of a daily APF cycle
- 2 - Activation of two daily APF cycles
- 3 - Activation of three daily APF cycles
- 4 - 30 minutes after the central power unit is turned off the APF cycle starts automatically.
- 5 - 30 minutes after the central power unit is turned off, the APF automatically starts, only if the 30% saturation threshold of the filter is exceeded.
- 6 - Manual activation of the APF cycle from the keyboard.

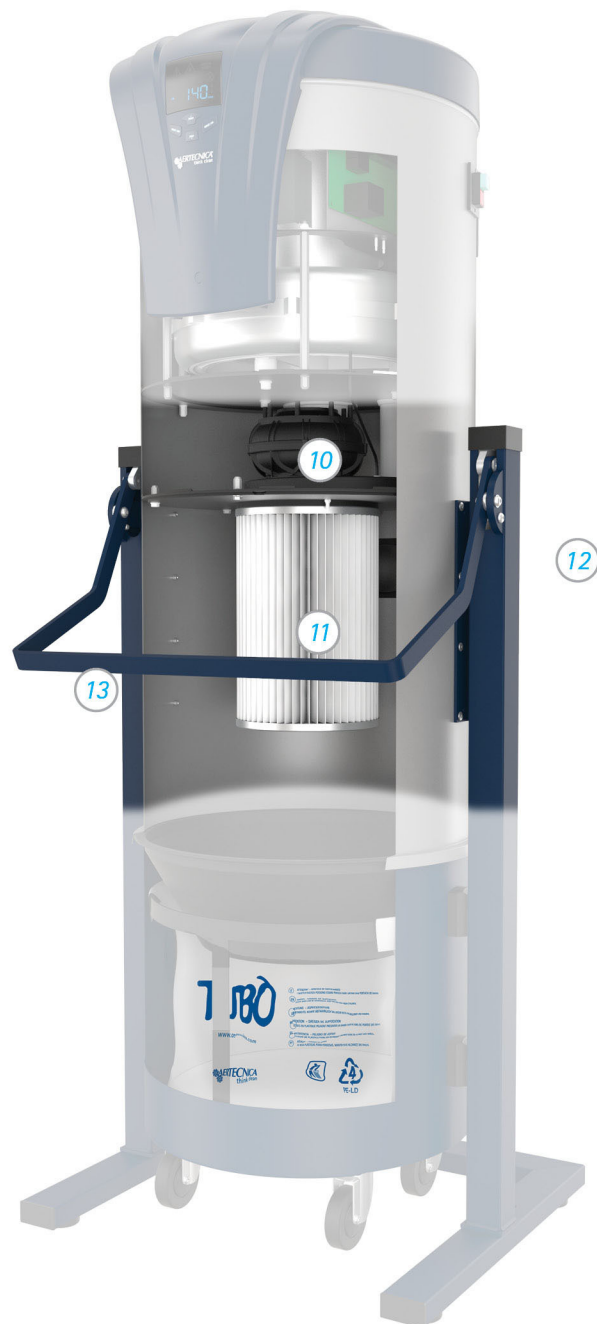

\* By default, the APF is set to mode 4, the duration of each APF cycle is 5 minutes and the APF is always active in manual mode. In the event that the vacuum system is activated during the scheduled filter self-cleaning cycle (APF System), the central vacuum unit restart time will be approximately 30 seconds. While the unit is running, the APF cannot be activated and the wording APF appears on the AVI display followed by the number that corresponds to the mode enabled.

APF System, Filter Self-Cleaning System, patented (Europe Patent Pending no. 06793421.6)





## X-PERT RT not only for professionals

- 14 **Deflector cone with seal:** is inserted inside the dust container. Thanks to its new deeper shape, more dust can be collected without it spreading throughout the machine body. The filter is kept clean in this way, providing longer-lasting performance.
- 15 **Dust collection bag with tensioner:** replacing the dust collection bag on the X-PERT RT is quick and easy. Its large size contains a greater quantity of dust, thereby reducing the number of maintenance tasks.
- 16 **"Quick Scroll" dust container with wheels:** The container is made of highly durable metal. The wheels and the Quick Scroll system allow you to move the central vacuum unit easily, which simplifies the maintenance.
- 17 **Anti-vibration base:** This stabilises the central vacuum unit and eliminates motor vibration when the vacuum unit is in operation.

### Opening/Closing of "QUICK SCROLL" Dust Container:

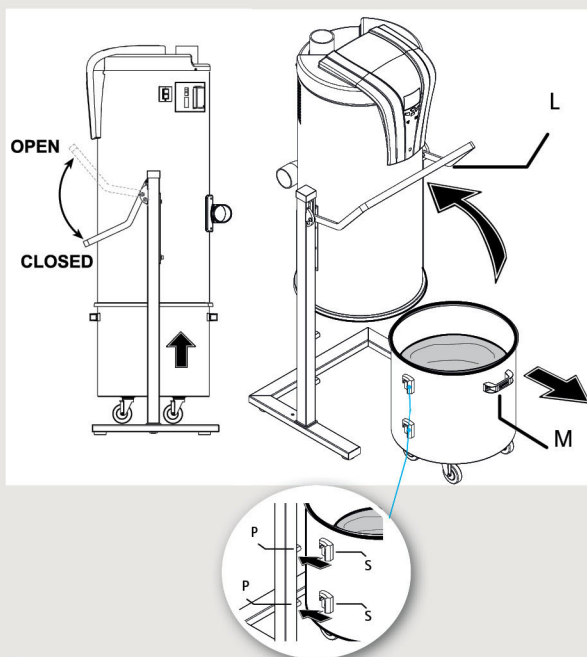

#### Open

Turn the special handle (L) upwards and remove the QUICK SCROLL dust container using the carrying handle (M).

#### Closing

Put the container inside the frame so that the two hooks (S) of the container are flush on the two pins (P) on the left and right side of the frame.



# Control Panel

The central vacuum unit has a control panel that includes an AVI display (immediate display) and a built-in keyboard to navigate and control the various central vacuum unit operating parameters.

## AVI Display

The alpha-numeric display is controlled by the electronic card and is used to control the following parameters:

### CLEAN BAG FILLING

This detects the filling level of the dust container and displays 4 different levels.

### FILTER CARTRIDGE SATURATION

This detects the saturation level of the filter cartridge and displays 5 different levels.

### OPERATING VACUUM RANGE

This displays the vacuum level at which the central power unit is operating:

LO (low) - OK (correct) - HI (High)

### OPERATING VACUUM

This displays the operating vacuum level of the central power unit

### MOTOR POWER PERCENTAGE

This displays the motor power percentage that is adjusted on the hose with the speed variator.

### TOTAL MOTOR HOURS

This displays the total hours of use of the central power unit.

### MOTOR TEMPERATURE

Displays the motor temperature.

### MOTOR TEMPERATURE ANOMALY/LOCK

Displays an anomaly/lock due to the engine temperature exceeding 80°C.

### MAXIMUM USE TIME ANOMALY/LOCK

Displays an anomaly/lock due to continuous use of the central power unit for 30 minutes.



### UNIT ANOMALY

This provides a generic report for a malfunction on the central vacuum unit



## KEYBOARD

The keyboard has 4 buttons that are used to perform the following functions:

- **START BUTTON**  
The START button activates the central vacuum unit. The arrow  is used to navigate the upper menu in the programme.
- **STOP BUTTON**  
The STOP button turns off the central unit. The arrow  is used to navigate the lower menu in the programme.
- **RESET/ESC BUTTON**  
The central unit can be reset after a block or anomaly by pressing the button. When you enter the programming mode, press ESC to exit the parameter.
- **MENU/OK BUTTON**  
If the button is pressed, it displays the central power unit's maintenance cycles. When you enter programming mode the OK button allows you to enter the parameter.



# Dynamic Control Display Everything Under Control (optional I Code CMT800)

Code CMT800 Dynamic Control Display (electric wall plate not included)

The Dynamic Control Display is Aertecnica's answer to home automation and it can be placed in any part of the building.

The display is aesthetically similar to any other electrical switch, allowing for perfect architectural integration.

Dynamic Control Display, Code CMT800, is an instrument that provides clear information that is easy to understand. It uses a set of icons and parameters that instantly report the operational status of the machine. It is equipped with a Reset function that automatically resets the system without having to access the machine in the event of a malfunction. The Dynamic Control Display automatically configures itself to the type of central vacuum unit it is connected to. Dynamic Control Display is an optional of the Tubò system.

- a** Dust collection Bag saturation
- b** Filter cartridge saturation
- c** Central vacuum unit ON indicator
- d** Operating + Reset buttons
- e** Display of operating parameters
- f** Pressure and maximum temperature gauge

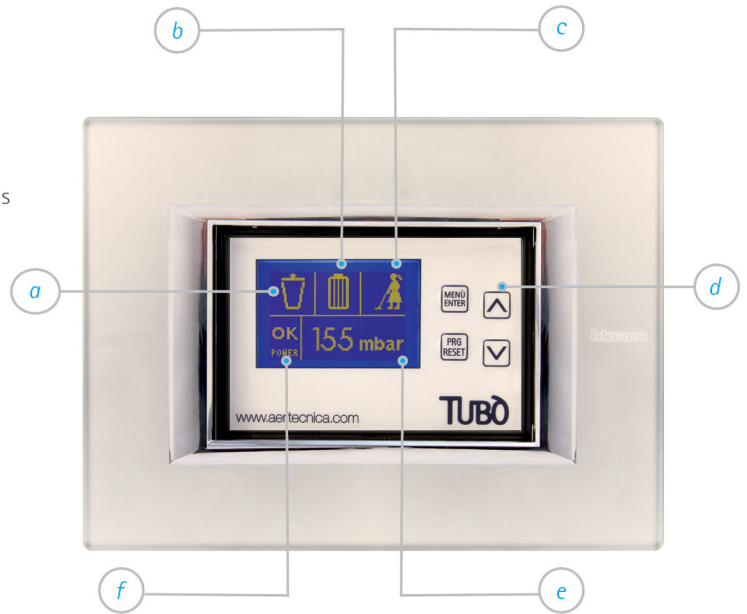

The Dynamic Control Display Code CMT800 communicates with the X-PERT central unit in Modbus mode, already set by default by the manufacturer.

For the connection between the X-PERT central vacuum unit and the Dynamic Control Panel, you require a power line cable with a section of not less than 2 x 0.25 mm.

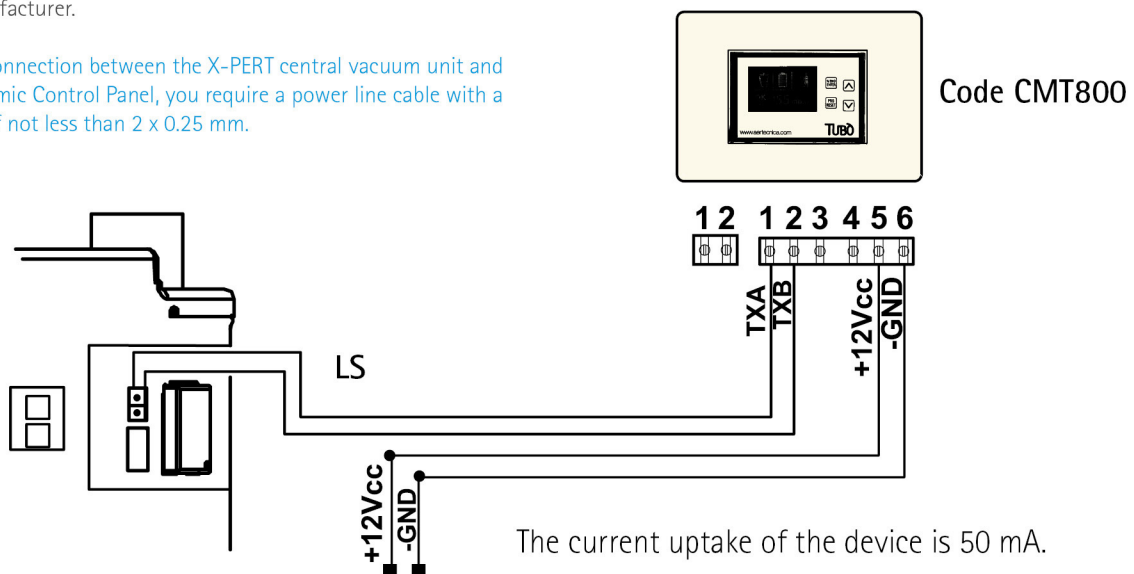



*Address:* Hastings 4120, New Zealand

*Phone:* 027 69 287 00

*Email:* [info@tubo.co.nz](mailto:info@tubo.co.nz)

*www.tubo.co.nz*



1985 - 2015

