

OPERATING MANUAL AIR EXHAUST FAN WA · WAV · WAB · WB · WC

IMPORTANT NOTICE

Please read the Operating Manual carefully before attempting to install or service the air exhaust fan! **AWENTA shall not be liable for any damage resulting from incorrect operation, non-intended use or unauthorized repair or modifications of the product.**

The Operating Manual and the installation instructions contained in it are an essential part of the product equipment. The Operating Manual specifies important technical information and instructions for the operating safety of the air exhaust fan. Carefully read the installation instructions in the Operating Manual. Keep the Operating Manual available for future reference. A copy of the Operating Manual can be downloaded from www.awenta.pl

Warnings

The following safety symbols show important safety information. Follow all safety regulations and the safety symbols shown in the Operating Manual to avoid injury and hazards.



Danger!



Electrocution hazard: high voltage!



Caution – rotating elements!

Safety precautions:

- This product can be used by children at least 8 years old, by people with impaired physical

and/or mental abilities, and by people without any experience in or understanding of the operation of the product, if supervised or instructed by a competent adult in the safe use of the product so that they understand the relevant operating risks. This product is not a toy and children should not play with it. Children should not be allowed to clean or maintain the product without supervision of an adult.

- The air exhaust fan is intended for permanent installation and connection with the building electrical system. The building electrical system connected to the air exhaust fan must be capable of breaking live voltage contact on all switching poles to fully isolate the air exhaust fan from power during Category III overvoltage conditions, in accordance to applicable electrical engineering regulations.
- The ventilator is designed for installation at a substantial height, i.e. 2.3 m above the floor. The air exhaust fan shall only be installed in a position and an orientation specified in the Operating Manual, given the necessary entry of the power cable into the air exhaust fan housing.

- Before servicing the air exhaust fan, isolate it from the mains voltage with the circuit breaker. Secure the circuit breaker against inadvertent operation.
- The air exhaust fan installation design must prevent reverse flow of flue gas into the room from open flue gas exhaust ducts and appliances operated with open flames.
- Never attempt to modify or alter the air exhaust fan without authorization.
- Before installing the air exhaust fan, verify the load bearing capacity of the installation substructure. Improper installation fastening may result in damage or failure of the air exhaust fan and hazards to the people nearby.



The air exhaust fan can be hazardous when operated against its intended use or installed by unqualified personnel.

Application and operating conditions

- The air exhaust fan is intended for handling indoor air of normal quality or with a low dust content (with a particle size < 10 μm) and without aggressive chemicals or high humidity. The air exhaust fan is intended for operation in temperate climate conditions and within the performance limits specified in the product catalogue.
- The air exhaust fan may be operated only in a permanent indoor installation and with its power supply line concealed.
- The maximum temperature of the medium handled by the air exhaust fan and the maximum ambient temperature are +40°C.
- The air exhaust fan is an IPX4 and protection class II device. The air exhaust fan can be installed in indoor moisture Zone II, ref. IEC 60364-7-701, provided that the following requirements from the air exhaust fan manufacturer are complied with:
 - 1 - the correct wall-mounting position is maintained with a proper seal of the power supply line in the grommet (see Section "Installation")
 - 2 - The air exhaust duct secures the air exhaust fan from direct exposure to water per IPX4 and direct access to live and/or rotating parts, including the fan rotor in motion; or the air exhaust duct is at least 800 mm long upstream of the air exhaust fan and installed with special tools which will be required to access the air exhaust fan for servicing.
- The air exhaust fan must be operated according to its intended use and within the performance limits specified on the nameplate.
- **Connect the air exhaust fan to the building mains (electrical system) with the following power cable: NYM-O 2x1.5 mm² (H07V-K 2x1.5 mm²) or NYM-O 3x1.5 mm² (H07V-K 3x1.5 mm²), maximum outer diameter 8 mm, according to the optional accessories provided (does not apply to the models with the supply cable attached).**
- Do not use the air exhaust fan to handle the air with the following content:

- viscous contaminants prone to deposition in the air exhaust fan,
- corrosive contaminants which may degrade the air exhaust fan,
- flammable contaminants, including gas, vapours, mists or particulates which may form explosive mixtures with air.
- The ball bearing units of the air exhaust fan are designed for a minimum operating life of 30,000 hours in S1 duty cycle at the maximum power output and the maximum ambient temperature.
- The control system must prevent extremely frequent power cycling.

Transport and storage

- Keep the air exhaust fans in their original packaging in a dry, sheltered room.
- The transport and storage ambient temperature limits are -20 °C to +40 °C.
- Protect against impact and shocks. Transport the air exhaust fan in its original packaging.
- If the storage time exceeds 1 year, the motor bearings of the air exhaust fan must be tested by turning the fan rotor by hand before installation. The fan rotor must run smoothly.
- Dispose of the air exhaust fan at the end of its operating life strictly in accordance with environmental protection and waste management laws.
- Should it occur, damage caused by improper transport, handling, storage or commissioning will be demonstrated and is not on warranty.

ACCESSORIES

Available optional accessories:

Terminal block (standard version, no part index suffix). *Connect the air exhaust fan with the terminal block as shown in the electrical wiring diagram shown in Fig. 3.*

The air exhaust fan is started and stopped by a separate on/off switch installed in the power supply line (and not included with the product).

Stop delay timer (part index suffix 'T'). *Connect the air exhaust fan with the stop delay timer (a stop delay switch) as shown in the electrical wiring diagram, see Fig. 4.*

The stop delay time can be set with a potentiometer knob on the electronic module of the stop delay timer. The minimum stop delay time is set at 3 min. with the potentiometer knob rotated counter-clockwise to stop. Turn the potentiometer knob clockwise to set a longer stop delay time accordingly. The maximum stop delay time setting is 30 min. The stop delay time is adjusted in infinite increments. The stop delay time is counted down from the time the air exhaust fan senses the indoor lights are off or turning the on/off switch off.

Humidity sensor (part name suffix 'H'). *Connect the air exhaust fan with the air humidity sensor (hygrostat) and timer as shown in the electrical wiring diagram in Fig.4 or Fig.5.*

The air humidity sensor operating range is 40% to 90% of relative humidity. This accessory option includes the stop delay timer. The operation of the air exhaust fan with these optional accessories will depend on the power supply connection method.

If connected as shown in Fig.5, the air exhaust fan will start automatically when the air humidity level exceeds the start threshold of the humidity sensor.

Next, the air exhaust fan will stop when the air humidity level is reduced below the stop threshold, plus the stop delay time set with the stop delay timer.

If connected as shown in Fig.4, the air exhaust fan can also be started with its standard light sensor (by turning off the indoor lights) or operating the separate on/off switch. When the indoor light is off or the on/off switch is turned off, the air exhaust fan will stop after the stop delay time set with the potentiometer if the humidity level in the room is below the level preset on the potentiometer. The humidity detection system is the master system.

CAUTION: When the green diode located in the electronic system is on, it means that the humidity level in the room is higher than the preset on the potentiometer controlling the humidity level adjustment. As long as the diode is on, the fan will not start counting down the stop delay after which the fan is switched off. It will take place only after the humidity level in the room drops and the green diode goes off.

Cord switch (part name suffix 'W'). *Connect the air exhaust fan with the cord switch as shown in the electrical wiring diagram in Fig. 5.*

The air exhaust fan is switched on and off by pulling the cord switch.

Cord switch + cable (part name suffix 'WP'). *Connect the air exhaust fan with the cord switch and the cable with a plug directly to the traditional wall socket type E (230V AC 50Hz).*

The air exhaust fan is switched on and off by pulling the cord switch.

Two speed (part name suffix 'DW'). *Connect the air exhaust fan with the two speed engine as shown in the electrical wiring diagram in Fig. 3.*

The air exhaust fan is started and stopped by a separate on/off switch installed in the power supply line (and not included with the product). Changing the rotation speed of the engine is done by pulling the cord switch.

Two speed + cable (part name suffix 'DWP'). *Connect the air exhaust fan with the two speed engine and the supply cable with a plug directly to the traditional wall socket type E (230V AC 50Hz).*

The fan is started by switching the switch situated on the power cable attached. Changing the rotation speed of the engine is done by pulling the cord switch.

INSTALLATION



The air exhaust fan shall only be installed, connected to electrical mains and commissioned for use by qualified personnel in accordance with applicable laws!

Assembly

Precisely choose the installation location of the air exhaust fan.

- Prepare the power cable to make the power supply line. Use NYM-O 2x1.5 mm² (H07V-K 2x1.5 mm²) or NYM-O 3x1.5 mm² (H07V-K 3x1.5 mm²), maximum outer diameter 8 mm, according to the optional accessories provided (does not apply to the models with the supply cable attached).
- Measure and drill the holes for the fan and for the ø6 mm wall bolt plugs included with the product.
- Remove the front clip-on bezel (1) of the air exhaust fan.
- Remove the housing panel (2) fixed with the screw (9).
- Run the power cable in double insulation through the grommet (8). Enough of the power cable must enter the air exhaust fan to facilitate connection of the cores to the power input terminals on the board (5). The minimum length of the cable in the external insulation is 10 mm (inside the chamber).

Before fastening the air exhaust fan to the installation substructure: remove all foreign objects from the inside of the air exhaust fan; check that the fan rotor turn freely by hand; check that there is enough clearance for the opening motion of the check damper closure on the air exhaust fan outlet end (the check damper is sold separately);

It is recommended to connect the air exhaust fan to the air exhaust ductwork with a flexible stub pipe!

- Align the air exhaust fan housing (7) with the holes and drive the wall bolt plugs into the holes.

CAUTION! While mounting at the wall, place the air exhaust fan so that the cable grommet is at its bottom!

- Remove the outer insulation from the power cable end and strip approximately 4 mm of the power cable core from the end.
- Arrange the power cable and connect its cores to the power input terminals according to the electrical wiring diagram applicable to the optional accessories provided.
- Protect the cable against sliding out, using the clamp (4) and the screws (3).
- Verify that the power cable cores are held tight by the terminals.
- Check the air exhaust fan for the soundness of mounting and correct electrical installation.
- Adjust the operating parameters as follows:

Part index suffix T, H: Set the time delay value and the humidity sensor sensitivity using a tool with rigid and flat pin and on the potentiometers located on the controller (5).

- attach the housing panel (2) to the middle part of the air exhaust fan housing (7) with the screw (9).
- Check that the power cable is sealed properly in all grommets and glands.
 - The power cable must be sealed to prevent ingress of water into the air exhaust fan along the power cable.
- Install the front panel (1) of the air exhaust fan. It serves as a direct touch guard.



CAUTION! Hazard of crushing fingers with the rotating fan rotor!
Install the guard against the direct touch of moving parts before starting.

First start

Start the air exhaust fan only with all safety precautions in place and all hazards eliminated. Start the air exhaust fan. Check that it runs steadily and the air is handled efficiently (out of the room and through the air exhaust ductwork to the outside).

Check the operation of the air exhaust fan (noise, vibration, the possibility to control the rotation speed).

Operate the air exhaust fan only with the front bezel installed, as it is a protection against touching the moving parts on the suction side.

Depending on the actual installation conditions, the air exhaust fan may require a protection against touching the moving parts on the delivery side. Suitable delivery-side direct guards can be provided on request. If the air exhaust fan is guarded against direct touch due to their installation conditions (e.g. in line with the air exhaust ductwork), no direct touch guard is required if the installation conditions provide an equivalent level of safety. Note that the air exhaust fan user is liable for compliance with current safety standards and may be held liable for accidental injury or death caused by failure to provide the required safety equipment.

Electrical connections

- Electrical connections and commissioning of the air exhaust fan shall only be completed by qualified professional electricians.
- Always follow the applicable standards, safety regulations and technical requirements specified by the power company!
- The power supply line for the air exhaust fan requires a multi-pole circuit breaker / isolation switch with a minimum contact break gap of 3 mm (ref. PN-EN 60335-1)!
- The mains system, voltage and frequency must match the nameplate ratings of the air exhaust fan.
- Air exhaust fans with the stop delay timer: the maximum voltage limit on terminal T to initiate the stop delay time countdown or start the air exhaust fan is approx. 130 V AC.

Dimensions

The dimensions of specific air exhaust fan models are shown in Fig. 1.

MAINTENANCE AND CLEANING

Servicing and maintenance

- Use protective footwear and gloves during maintenance!
- During all maintenance and servicing works the electrical and OHS regulations (PN-IEC 60364-3) must be observed.
- Before servicing the air exhaust fan, isolate it from the mains voltage with the circuit breaker. Secure the circuit breaker against inadvertent operation!
- The air exhaust fan ductwork must be clear of foreign bodies: hazard of injury by objects blown out at a high speed!
- Do not attempt any maintenance when the air exhaust fan is running or at live voltage!
- If excessive vibrations are felt or heard, have the technical inspection carried out by a qualified electrician.
- The maintenance intervals depend on the actual contamination of the fan rotor and must not be longer than 6 months!
- Check the fan rotor for cracks.
- The manufacturer shall not be liable for any damage resulting from unprofessional repairs.
- For equipment where engines with "lifetime lubrication" have been used, the engine does not require lubrication.
- **Part index suffix WP, DWP:** If the non-detachable power cord is damaged, it should be replaced by the manufacturer or service agent, or by a qualified person in order to avoid a hazard.

Cleaning



Electrocution hazard by damaged wiring insulation!

Before attempting to clean the air exhaust fan, isolate it from the mains voltage with the circuit breaker.

Secure the circuit breaker against inadvertent operation!

- Clean the front panel and the visible parts of the housing with a damp cloth.
- Do not use aggressive paint solvents!
- Do not clean with a high pressure cleaner or strong jets of water!

- Clean carefully to prevent water from entering the motor or the terminal box.
- Always keep the guard grille at the suction side clean.

WARRANTY TERMS & CONDITIONS

1. The warranty period for the proper operation of the fan is 2 or 5 years, depending on the model (see information on the packaging), from the date of sale.
2. The warranty rights and obligations will be void and null without demonstrating a proof of purchase (a receipt or an invoice).
3. The warranty covers all defects and damage attributable to the manufacturer.
4. Have your product delivered for warranty servicing to the manufacturer or the original seller.
5. The manufacturer undertakes to repair the product or replace it with a new counterpart within 14 days from filing your warranty complaint.
6. The warranty does not cover any of the following: damage to the product attributable to improper or unqualified installation, operation against the intended use, improper transport, storage and/or maintenance, any faults attributable to unauthorized repairs, or any accidental damage.
7. The warranty does not cover the installation or the maintenance of the product.
8. The product's performance and warranty eligibility require periodic maintenance of the product by qualified professionals at least every 6 months.
9. For all matters not provided for by this Warranty Certificate, the Polish Civil Code (Articles 577- 582) shall apply.

Do not dispose of waste electrical equipment with household waste.



The crossed-out wheelee bin symbol on this product means that it is waste of electrical and electronic equipment (WEEE) at the end of its operating life and shall not be disposed with household waste. The crossed-out wheelee bin symbol specifies that the product is subject to obligatory waste segregation schedules for proper disposal. The product is made from recyclable materials and components. The product user is required to return the product which has become WEEE to a WEEE collection unit. The operators of WEEE collection units, including local WEEE locations, product resellers and other WEEE collection locations managed by local authorities form a proper waste disposal system. Proper WEEE disposal helps avoid harmful effects to humans and the environment from the risk caused by hazardous components this product may contain. The household plays an important role in contributing to reuse and recovery, including recycling, of used up appliances, and it is the stage where attitudes are created that impact the preservation of the common being the clean natural environment. Households are among the leading consumers of small appliances and equipment. A rational management of operation and disposal of small appliances and equipment will contribute to efficient recycling.

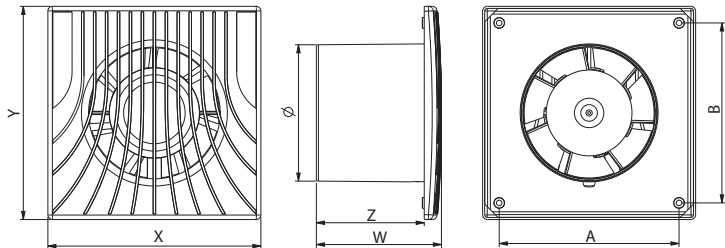

Rys. 1
Fig. 1
Изобр. 1
Obr. 1

INDEX / ИНДЕКС	Ø	A	B	X	Y	W	Z
WA100	100	130	130	154	154	87	77
WAV100	100	130	130	154	154	87	77
WAB100	100	130	130	154	154	87	77
WB100	100	130	130	154	154	98	77
WC100	100	130	130	154	154	92	78
WA120	120	130	130	154	154	87	77
WAV120	120	130	130	154	154	87	77
WC120	120	130	130	154	154	92	78
WA150	150	162	162	188	188	97	77

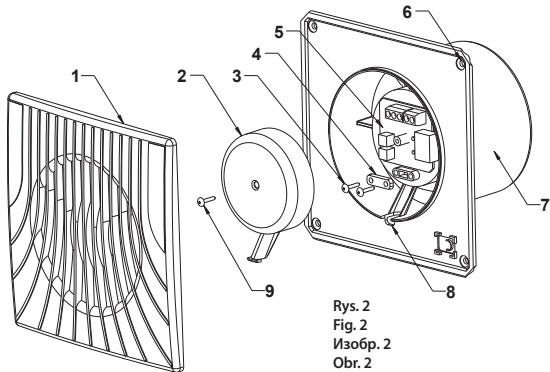

Rys. 2
Fig. 2
Изобр. 2
Obr. 2

Awenta
SINCE 1989

Producent / Manufacturer / Производитель / Výrobce / Výrobca:
AWENTA Spółka Jawna
05-300 Mińsk Mazowiecki, Stojadła, ul. Warszawska 99, Poland
Tel: +48 25 758 52 52, + 48 25 758 93 92 fax: +48 25 758 14 62
e-mail: info@awenta.pl www.awenta.pl

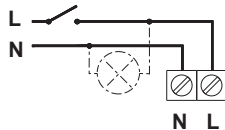

Rys. 3
Fig. 3
Изобр. 3
Obr. 3

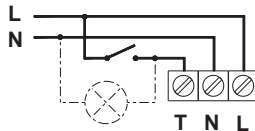

Rys. 4
Fig. 4
Изобр. 4
Obr. 4

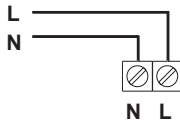

Rys. 5
Fig. 5
Изобр. 5
Obr. 5