

TCMP

400 °C/2h centrifugal extractor fans with forward curved impeller



400 °C/2h centrifugal single inlet extractor fans for outdoor operation in fire risk zones.

Fan:

- Sheet steel casing.
- Forward curved impeller in galvanized sheet steel.
- Approved in accordance with standard EN 12101-3, with certificate no.: 0370-CPR- 0313.

Motor:

- Class F motors with ball bearings and IP55 protection.
- Motors with IE3 efficiency for powers equal to or greater than 0,75 kW, except single-phase, 2-speed and 8-pole.

- Three-phase 230/400 V 50 Hz (up to 4 kW) and 400/690 V 50 Hz (powers greater than 4 kW).
- Maximum temperature of air to be carried: S1 -20 °C+ 250 °C continuous service. S2 300 °C/2h and 400 °C/2h service.

Finishing:

- Anti-corrosive finish in polyester resin, polymerised at 190 °C, after degreasing with phosphate-free nanotechnology treatment.

On request:

- Fans with 2 speed motor.
- Belt-driven extractor fans.

Order code

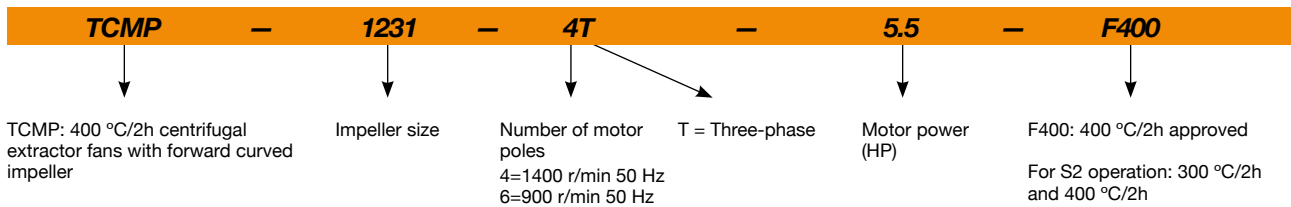

Technical characteristics

Model	Speed (r/min)	Maximum admissible current (A)			Installed power (kW)	Maximum flow rate (m³/h)	Sound pressure level dB (A)	Approx. weight (Kg)
		230V	400V	690V				
TCMP-820-4T	1350	1.66	0.96		0.25	1670	58	11
TCMP-922-4T	1380	2.92	1.69		0.55	2450	59	20
TCMP-1025-4T-1.5 IE3	1455	4.07	2.34		1.10	3400	63	28
TCMP-1025-4T-2 IE3	1440	5.41	3.11		1.50	3650	65	31
TCMP-1128-4T-3 IE3	1435	7.93	4.56		2.20	5000	67	38
TCMP-1128-4T-4 IE3	1440	10.70	6.15		3.00	5450	68	41
TCMP-1128-6T IE3	940	3.36	1.93		0.75	3300	53	30
TCMP-1231-4T-3 IE3	1435	7.93	4.56		2.20	4740	68	45
TCMP-1231-4T-4 IE3	1440	10.70	6.15		3.00	5910	70	48
TCMP-1231-4T-5.5 IE3	1450	13.90	8.00		4.00	6850	72	55
TCMP-1231-6T IE3	950	6.43	3.70		1.50	5120	59	45
TCMP-1435-4T-4 IE3	1440	10.70	6.15		3.00	5400	71	55
TCMP-1435-4T-5.5 IE3	1450	13.90	8.00		4.00	6260	73	62
TCMP-1435-4T-7.5 IE3	1465		10.30	5.97	5.50	7210	75	72
TCMP-1435-4T-10 IE3	1465		13.90	8.06	7.50	9380	74	80
TCMP-1435-6T IE3	950	9.08	5.22		2.20	6400	63	57

Technical characteristics

Model	Speed (r/min)	Maximum admissible current (A)			Installed power (kW)	Maximum flow rate (m³/h)	Sound pressure level dB (A)	Approx. weight (Kg)
		230V	400V	690V				
TCMP-1640-4T-5.5 IE3	1450	13.90	8.00		4.00	7000	72	81
TCMP-1640-4T-7.5 IE3	1465		10.30	5.97	5.50	8040	75	91
TCMP-1640-4T-10 IE3	1465		13.90	8.06	7.50	9710	74	99
TCMP-1640-6T IE3	950	9.08	5.22		2.20	8100	66	76
TCMP-1845-4T-7.5 IE3	1465		10.30	5.97	5.50	8000	79	100
TCMP-1845-4T-10 IE3	1465		13.90	8.06	7.50	10000	79	108
TCMP-1845-6T IE3	950	9.08	5.22		2.20	7500	74	85
TCMP-2050-4T-10 IE3	1465		13.90	8.06	7.50	9000	77	130
TCMP-2050-4T-15 IE3	1470		20.90	12.10	11.00	12520	81	154
TCMP-2050-4T-20 IE3	1465		27.90	16.20	15.00	16500	83	166
TCMP-2050-6T IE3	960	15.60	8.99		4.00	11000	76	125



Erp. (Energy Related Products)

Information on Directive 2009/125/EC can be downloaded from the SODECA website or the QuickFan selector programme.

Acoustic characteristics

The indicated values are determined by measuring the sound pressure level and sound power in dB(A) obtained in a free field at a distance equivalent to twice the size of the fan plus the impeller diameter, with a minimum of 1.5 m.

Sound power spectrum Lw(A) in dB(A) per Hz frequency band

	63	125	250	500	1000	2000	4000	8000		63	125	250	500	1000	2000	4000	8000
TCMP-820-4T	40	50	61	68	72	69	67	60	TCMP-1435-4T-10	57	66	77	84	88	86	84	77
TCMP-922-4T	41	51	62	69	73	70	68	61	TCMP-1435-6T	46	55	66	73	77	75	73	66
TCMP-1025-4T-1.5	45	55	66	73	77	74	72	65	TCMP-1640-4T-5.5	55	64	75	82	86	84	82	75
TCMP-1025-4T-2	47	57	68	75	79	76	74	67	TCMP-1640-4T-7.5	58	67	78	85	89	87	85	78
TCMP-1128-4T-3	49	59	70	77	81	78	76	69	TCMP-1640-4T-10	57	66	77	84	88	86	84	77
TCMP-1128-4T-4	50	60	71	78	82	79	77	70	TCMP-1640-6T	49	58	69	76	80	78	76	69
TCMP-1128-6T	35	45	56	63	67	64	62	55	TCMP-1845-4T-7.5	61	71	82	89	93	91	89	81
TCMP-1231-4T-3	51	60	71	78	82	80	78	71	TCMP-1845-4T-10	61	71	82	89	93	91	89	81
TCMP-1231-4T-4	53	62	73	80	84	82	80	73	TCMP-1845-6T	56	66	77	84	88	86	84	76
TCMP-1231-4T-5.5	55	64	75	82	86	84	82	75	TCMP-2050-4T-10	59	69	80	87	91	89	87	79
TCMP-1231-6T	42	51	62	69	73	71	69	62	TCMP-2050-4T-15	63	73	84	91	95	93	91	83
TCMP-1435-4T-4	54	63	74	81	85	83	81	74	TCMP-2050-4T-20	65	75	86	93	97	95	93	85
TCMP-1435-4T-5.5	56	65	76	83	87	85	83	76	TCMP-2050-6T	58	68	79	86	90	88	86	78
TCMP-1435-4T-7.5	58	67	78	85	89	87	85	78									

Orientations

Standard supply LG 270

Positions LG 180 and RD 180 on request with special anchoring measurements.

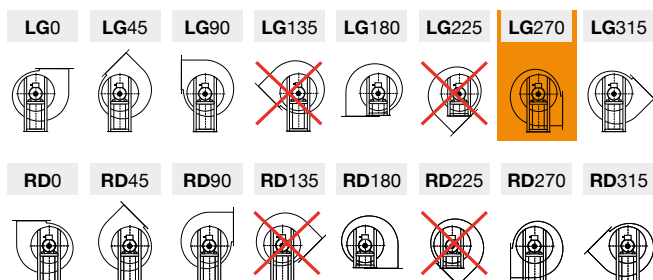

Dimensions mm

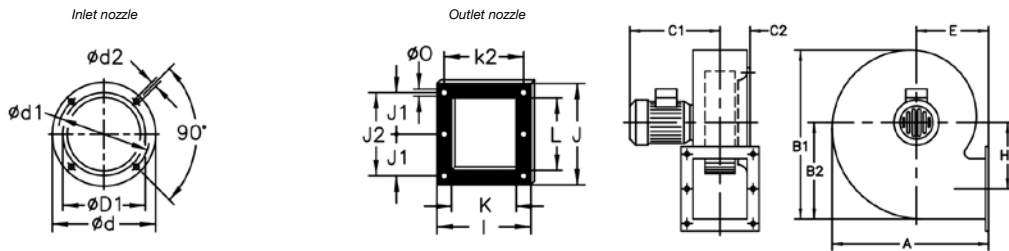

	A	B1	B2	C1	C2	ØD1*	Ød	Ød1	Ød2	E	H1	I	J	J1	J2	K	k2	L	Ø0
TCMP- 820-4T	322	377	223	300	68	203	245	230	M6	137	137	184	213	95	189	134	160	158	9

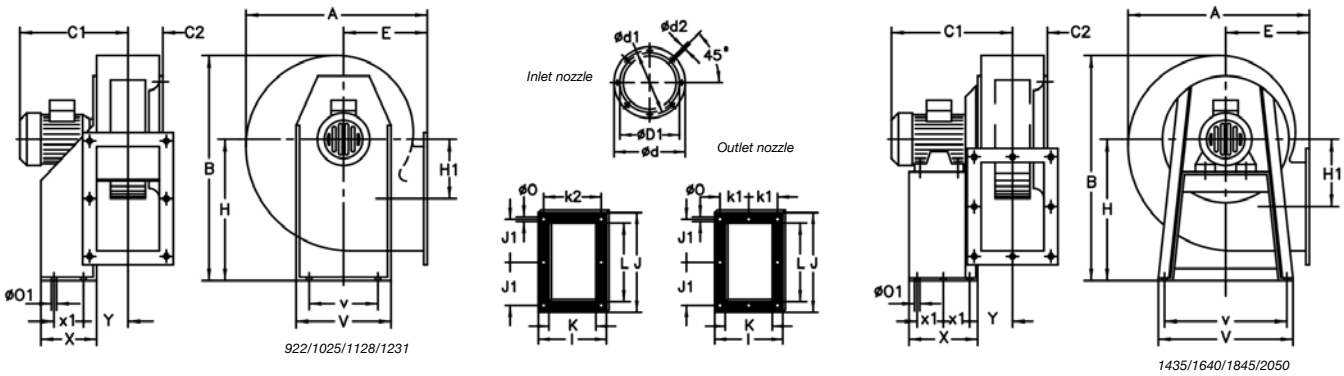

	A	B	C1	C2	ØD1*	Ød	Ød1	Ød2	E	H	H1	I	J	J1	K	k1	k2	L	Ø0	Ø01	V	v	X	x1	Y
TCMP-922	388	455	346	73	230	284	256	M8	180	280	134	204	282	128	140	-	180	217	9.5	10.5	290	220	114	50	104
TCMP-1025	427	503	384	86	261	308	282	M8	197	310	144	229	312	145	165	-	205	252	9.5	12.5	315	228	134	74	115
TCMP-1128-4T	472	553	444	94	287	348	320	M8	216	340	152	244	364	170	180	-	220	299	10	12.5	348	245	144	95	122
TCMP-1128-6T	472	553	359	93	287	348	320	M8	216	340	152	244	364	170	180	-	220	299	10	12.5	348	245	144	95	122
TCMP-1231-3	526	631	432	103	315	382	354	M8	238	390	179	264	382	180	200	-	240	322	12	13	382	322	183	140	125
TCMP-1231-4	526	631	432	103	315	382	354	M8	238	390	179	264	382	180	200	-	240	322	12	13	382	322	183	140	125
TCMP-1231-5.5	526	631	455	103	315	382	354	M8	238	390	179	264	382	180	200	-	240	322	12	13	382	322	183	140	125
TCMP-1231-6T	526	631	432	103	315	382	354	M8	238	390	179	264	382	180	200	-	240	322	12	13	382	322	183	140	125
TCMP-1435-4	573	715	453	118	355	422	394	M8	250	445	242	292	342	159	228	133	-	282	11.5	12	456	420	333	136.5	149.5
TCMP-1435-5.5	573	715	469	118	355	422	394	M8	250	445	242	292	342	159	228	133	-	282	11.5	12	456	420	333	136.5	149.5
TCMP-1435-7.5	573.5	715	512	118	355	422	394	M8	250	445	242	292	342	159	228	133	-	280	11.5	12	456	420	333	136.5	149.5
TCMP-1435-10	573.5	715	512	118	355	422	394	M8	250	445	242	292	342	159	228	133	-	280	11.5	12	456	420	333	136.5	149.5
TCMP-1435-6T	573	715	469	118	355	422	394	M8	250	445	242	292	342	159	228	133	-	282	11.5	12	456	420	333	136.5	149.5
TCMP-1640-5.5	634	799	480	130	402	464	438	M8	270	495	271	336	404	185	250	150	-	324	11.5	12	500	460	327	134	161
TCMP-1640-7.5	634	799	553	130	402	464	438	M8	270	495	271	336	404	185	250	150	-	324	11.5	12	500	460	327	134	161
TCMP-1640-10	634	799	553	130	402	464	438	M8	270	495	271	336	404	185	250	150	-	324	11.5	12	500	460	327	134	161
TCMP-1640-6T	634	799	480	130	402	464	438	M8	270	495	271	336	404	185	250	150	-	324	11.5	12	500	460	327	134	161
TCMP-1845-4T	710	901	570	147	453	515	485	M8	302	560	305	370	444	202	284	164	-	364	11.5	12	538	502	340	140	178
TCMP-1845-6T	710	901	497	147	453	515	485	M8	302	560	305	370	444	202	284	164	-	364	11.5	12	538	502	340	140	178
TCMP-2050-10	797	987	600	162	500	565	535	M8	345	610	313	411	544	250	315	182.5	-	454	11.5	12	653	615	435	187.5	194.5
TCMP-2050-15	797	987	694	162	500	565	535	M8	345	610	313	411	544	250	315	182.5	-	454	11.5	12	653	615	435	187.5	194.5
TCMP-2050-20	797	987	694	162	500	565	535	M8	345	610	313	411	544	250	315	182.5	-	454	11.5	12	653	615	435	187.5	194.5
TCMP-2050-6T	797	987	600	162	500	565	535	M8	345	610	313	411	544	250	315	182.5	-	454	11.5	12	653	615	435	187.5	194.5

* Recommended nominal tube diameter

Characteristic curves

Q= Flow rate in m³/h, m³/s and cfm

Pe= Static pressure in mm H₂O, Pa and inwg

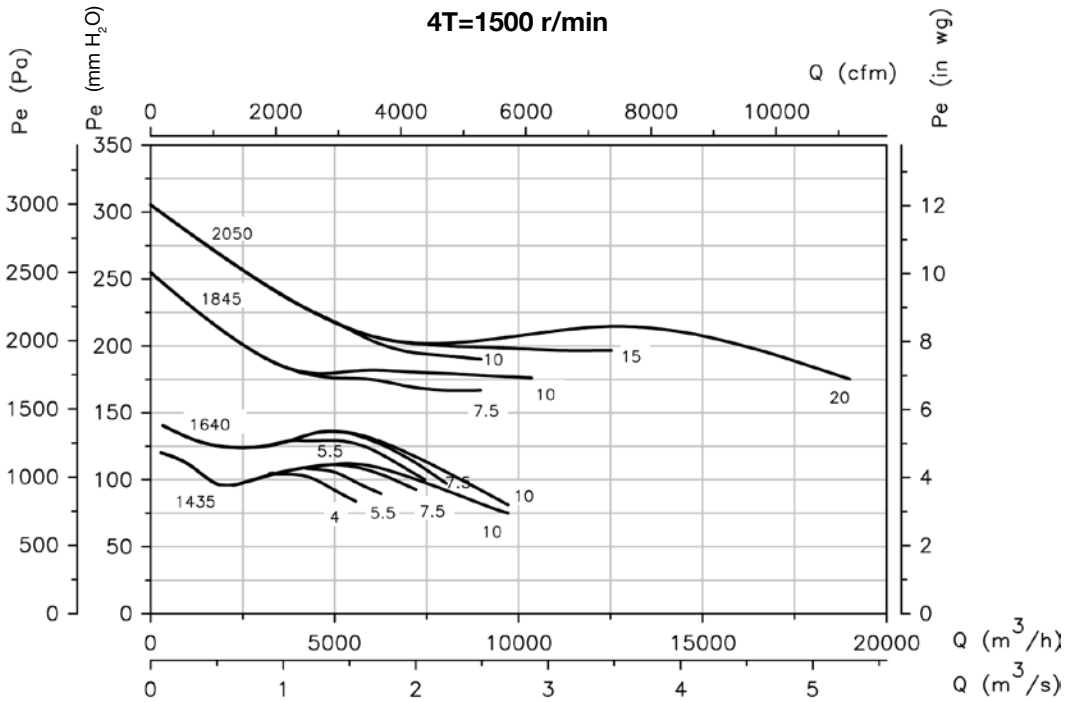
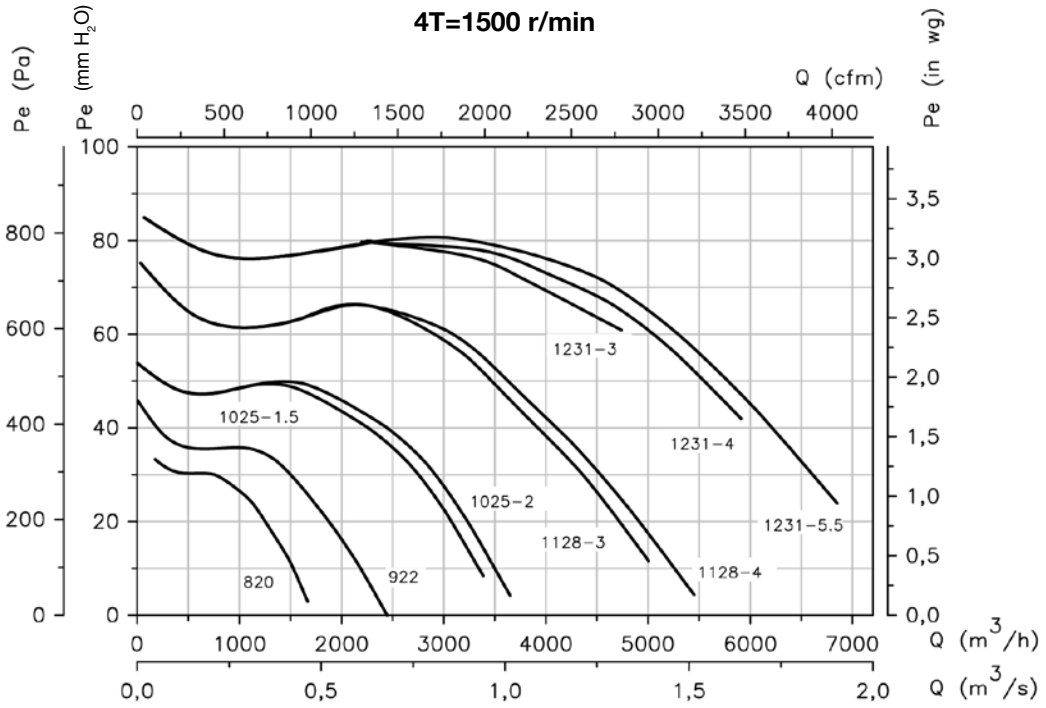

Characteristic curves

Q= Flow rate in m³/h, m³/s and cfm Pe= Static pressure in mm H₂O, Pa and inwg

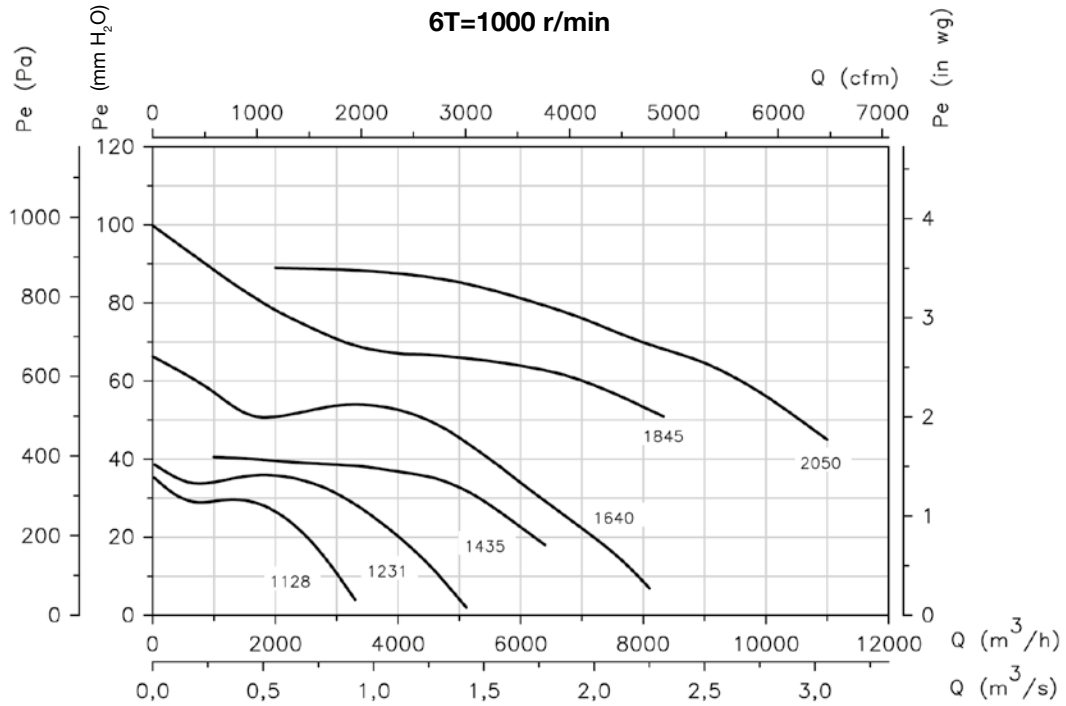

Accessories

