

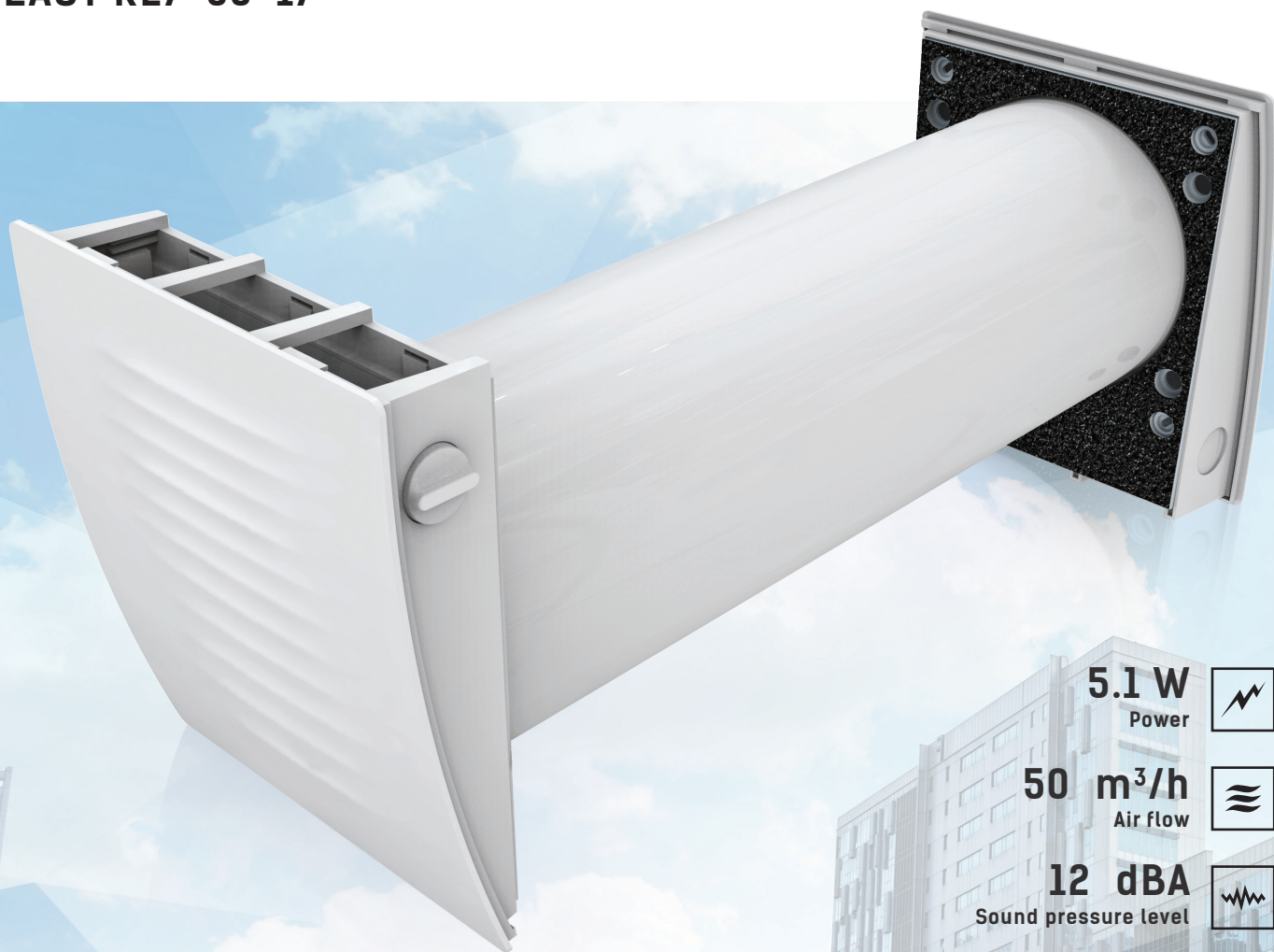

# SINGLE-ROOM HEAT REGENERATION UNIT

EASY RL7-50-17



**5.1 W**  
Power 

**50 m<sup>3</sup>/h**  
Air flow 

**12 dBA**  
Sound pressure level 

# EFFICIENT, RELIABLE AND ENERGY SAVING VENTILATORS 24/7:



Provide fresh air supply



Consume little energy



Extract stale air from the room

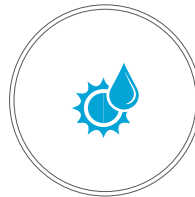

Maintain heat regeneration and indoor humidity balance

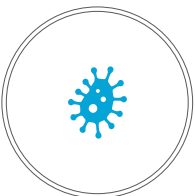

Prevent excessive indoor humidity and mould build-up



Reduce heating and air conditioning costs



Attenuate indoor noise



Clean air of dust and insects



# VENTILATOR DESIGN

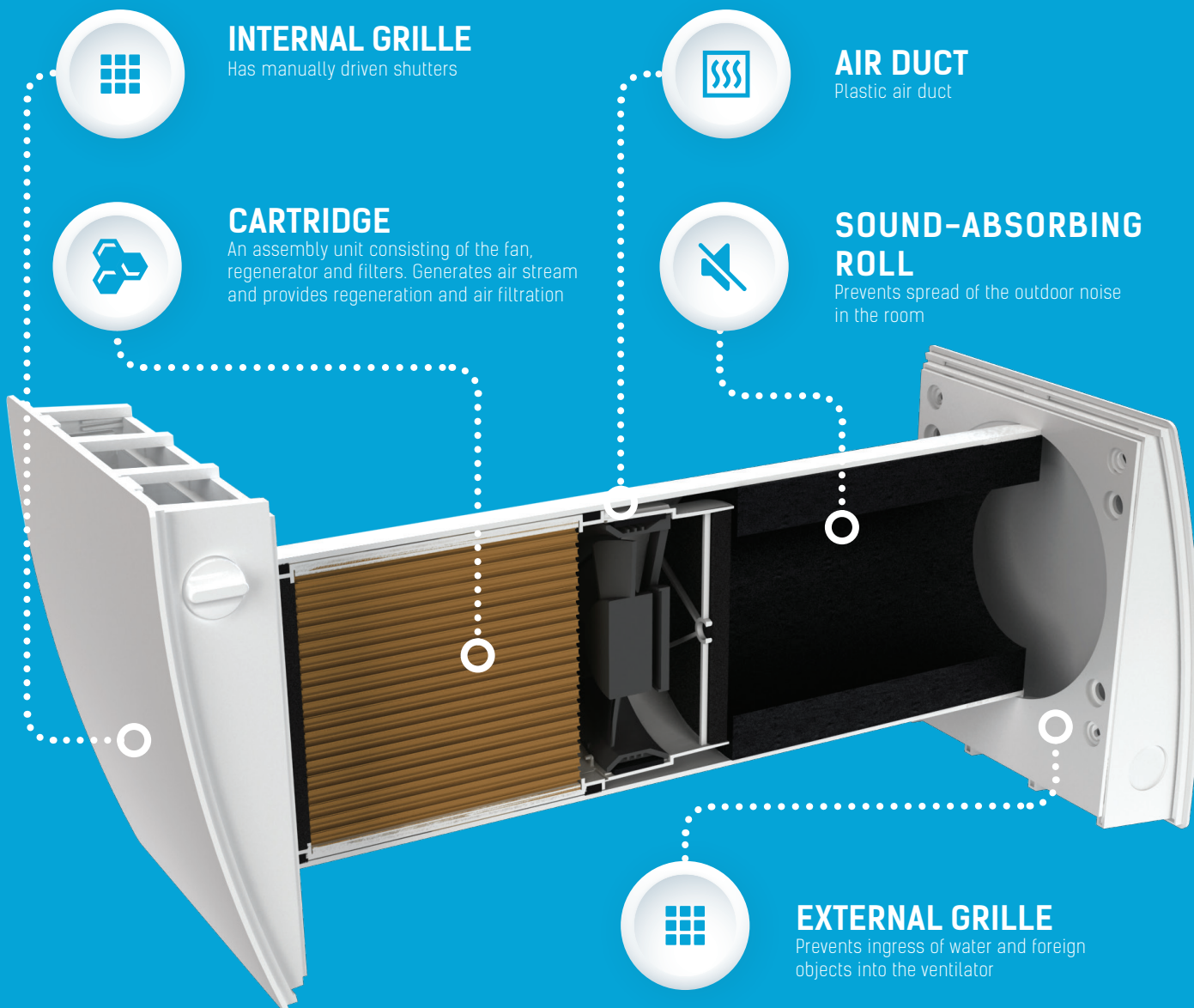

● **CERAMIC ENERGY REGENERATOR**

The high-tech ceramic energy accumulator with regeneration efficiency up to 97 % ensures extract air heat recovery for warming of supply air flow. Due to the cellular structure the unique regenerator has a large air contact surface and high heat-conducting and heat-accumulating properties.

The ceramic regenerator is treated with an antibacterial composition which prevents bacteria growth inside of the energy regenerator. The antibacterial properties last for 10 years.

● **AIR FILTERS**

The two integrated air filters with total filtration rate G3 provide supply and extract air filtration. The filters prevent ingress of dust and insects into the supply air and contamination of the ventilator parts. The filters also have antibacterial treatment.

The filter cleaning is done with a vacuum cleaner or water flushing. The antibacterial solution is not removed. F8 filter is available as a specially ordered accessory, but when installed, it reduces the air flow down to 40 m<sup>3</sup>/h.

● **REVERSIBLE DC-FAN**

The reversible axial fan with a DC motor and power supply voltage of 12 V serves for air supply and exhaust. Due to the applied DC technology the fan is featured with low power consumption. The fan motor has integrated thermal overheating protection and ball bearings for long service life.

# CONTROL AND OPERATION MODES

The ventilator is operated with the wall-mounted control panel or the remote control for your convenience.

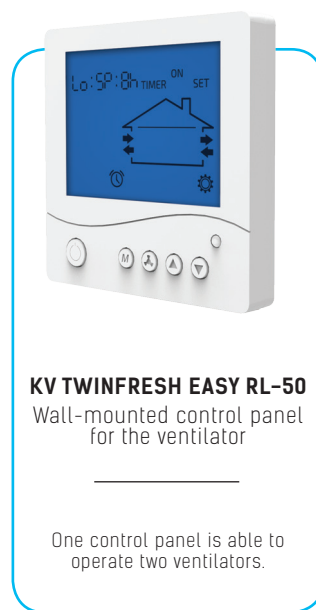

## OPERATION MODES:

- **Ventilation mode.** The ventilator runs in the air extract or air supply mode with a set speed. In case of synchronous operation of two connected ventilators one unit operates in the supply mode and the other one in the extract mode.
- **Regeneration mode.** The ventilator runs in two cycles, 70 seconds each, to provide heat and moisture regeneration.
  - **interval 1.** The warm polluted air is extracted from the room and flows through the ceramic regenerator, which gradually absorbs heat and moisture. In 70 seconds after warming is started the ventilator switches to the air supply mode.
  - **interval 2.** The fresh and cold outdoor air flows through the heat regenerator and absorbs the accumulated moisture and heat so that the supply air flow has the room temperature. In 70 seconds, when the energy regenerator gets cold, the ventilator switches to the air extract mode. The cycle starts from the beginning. If two ventilators are installed, they run in opposite phases. While one ventilator supplies fresh air, the second one extracts air from the room.

# FUNCTIONING OF THE VENTILATORS

The reversible operation of the ventilator enables energy regeneration and consists of two cycles:

## ● CYCLE I

The polluted warm air is extracted from the room and while passing the ceramic energy regenerator, it transfers the heat and moisture to it. In 70 seconds, as the energy regenerator gets warmed, the ventilator automatically switches to the supply mode.

## ● CYCLE II

The fresh, but cold outdoor air flows through the heat regenerator and absorbs the accumulated moisture and heat so that the supply air flow has the room temperature. In 70 seconds, when the energy regenerator gets cold, the ventilator switches to the air extract mode. The cycle starts from the beginning. The changeover between the supply and extract modes takes place each 70 seconds.

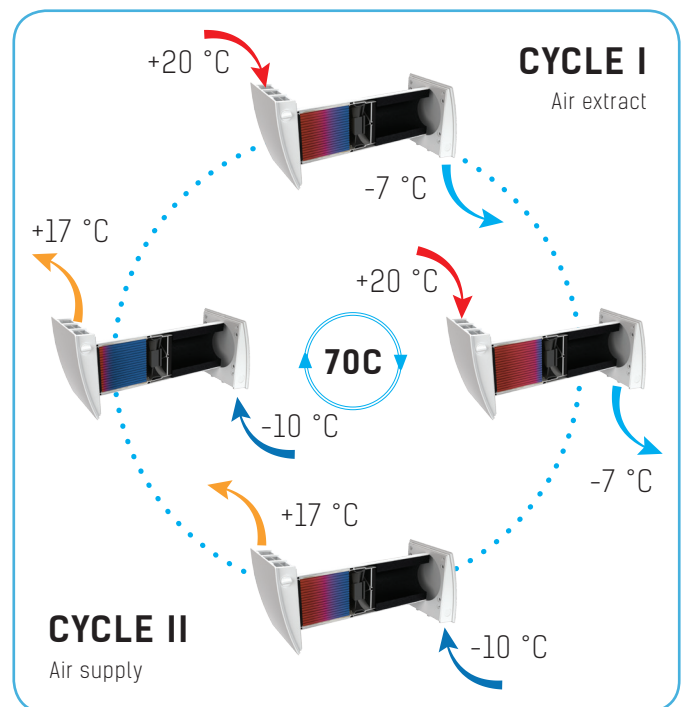

# USE

The ventilator is designed to ensure continuous mechanical air exchange in houses, offices, hotels, cafes, conference halls and other residential and public premises. The ventilator is equipped with a ceramic regenerator that enables supply of fresh filtered air heated by means of extract air heat regeneration. The ventilator is designed for through-the-wall mounting and is rated for non-stop operation. Transported air must not contain any flammable or explosive mixtures, evaporation of chemicals, sticky substances, fibrous materials, coarse dust, soot and oil particles or environments favourable for the formation of hazardous substances (toxic substances, dust, pathogenic germs).

# TECHNICAL DATA

Specific energy consumption (SEC), kWh/(m <sup>2</sup> ·a)	Cold		Average		Warm	
	-75.1	A+	-35.6	A	-13.0	E
Type of ventilation unit	Bidirectional					
Type of drive installed	Three-speed					
Type of heat recovery system	Regenerative					
Thermal efficiency of heat recovery, %	77					
Maximum flow rate, m <sup>3</sup> /h	25					
Electric power input, W	5					
Sound power level, dBA	38					
Reference flow rate, m <sup>3</sup> /s	0.004					
Reference pressure difference, Pa	0					
Specific power input (SPI), W/(m <sup>3</sup> /h)	0.180					
Control typology	Clock control					
Maximum internal leakage rates, %	2.7					
Maximum external leakage rates, %	0					
Mixing rate of bidirectional units, %	1					
Airflow sensitivity at +20 Pa and -20 Pa	0.40					
The indoor/outdoor air tightness, m <sup>3</sup> /h	0.5					
Internet address	<a href="http://www.ventilation-system.com/">http://www.ventilation-system.com/</a>					
Annual electricity consumption (AEC), kWh electricity/a	Cold	Average		Warm		
	230	230		230		
Annual heating saved (AHS), kWh primary energy/a	Cold	Average		Warm		
	8089	4135		1870		

Speed	1	2	3
Voltage [V/Hz]	100-240 / 50-60		
Power consumption [W]	1.00	2.10	4.30
Total current consumption [A]	0.017	0.025	0.041
Air flow [m <sup>3</sup> /h] (CFM)	15 (9)	30 (18)	50 (29)
Air flow in regeneration mode [m <sup>3</sup> /h] (CFM)	8 (4)	15 (9)	25 (15)
Power input [W/l/s]	0.48	0.50	0.62
RPM	915	1555	2330
Sound pressure level @ 1 m [dBA]	21	27	29
Sound pressure level @ 3 m [dBA]	12	18	20
Outdoor sound pressure attenuation [dBA] (Sones)	41 (2.5)		
Regeneration efficiency [%]	≤ 92		
Transported air temperature [°C] (Sones)	-15 ... +50 (5... +122)		
Filter	G3 (F8 optionally)		
F8 filter filtration rate PM2.5 [%]	99		
Air flow with F8 filter applied [m <sup>3</sup> /h]	40		

\* -30 °C (-22 oF) if S3 TwinFresh cartridge and EH-13 hood are applied

**ENERG** Y UA  
енергия · ενεργεια  
IE IA

**VENTS** TwinFresh Easy  
RL7-50-17

38  
dB

25 m<sup>3</sup>/h

ENERGIA · ΕΝΕΡΓΙΑ · ΕΝΕΡΓΕΙΑ · ENERGIJA · ENERGY · ENERGIE · ENERGI  
2018 1254/2014

## OVERALL DIMENSIONS

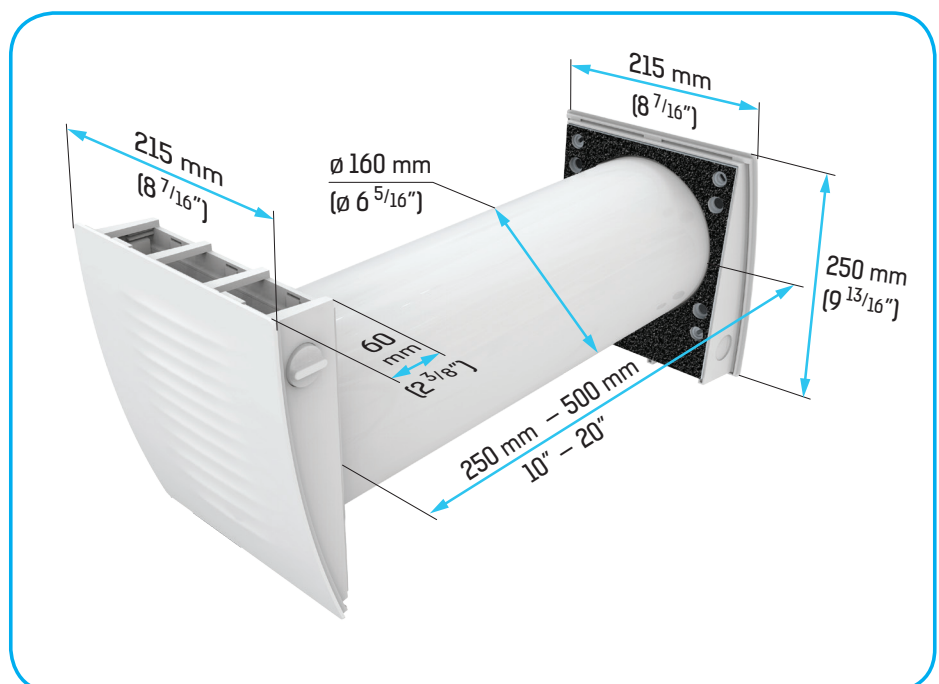

# VENTILATION ARRANGEMENT EXAMPLE

The ventilation system based on the TwinFresh ventilators provides for one ventilator in each room. For bigger rooms two and more ventilators are recommended. To ensure balanced ventilation, it is advisable to use a paired number of ventilators and connect those into a single network. Some ventilators must be set to operate in the supply mode and the other ventilators must be set to operate in the extract mode. TwinFresh may be used as an individual unit. In this case the ventilation mode must be selected individually for each room.

Air moves between the rooms through the door openings and corridors and this way the required air circulation in the house is arranged. The ventilation system with energy regeneration based on the TwinFresh ventilators significantly reduces heating and air conditioning costs. iFan WiFi fans are recommended for very efficient extract ventilation in the kitchen and bathroom. Polluted air is extracted automatically in case of actuation of the motion or humidity sensors.

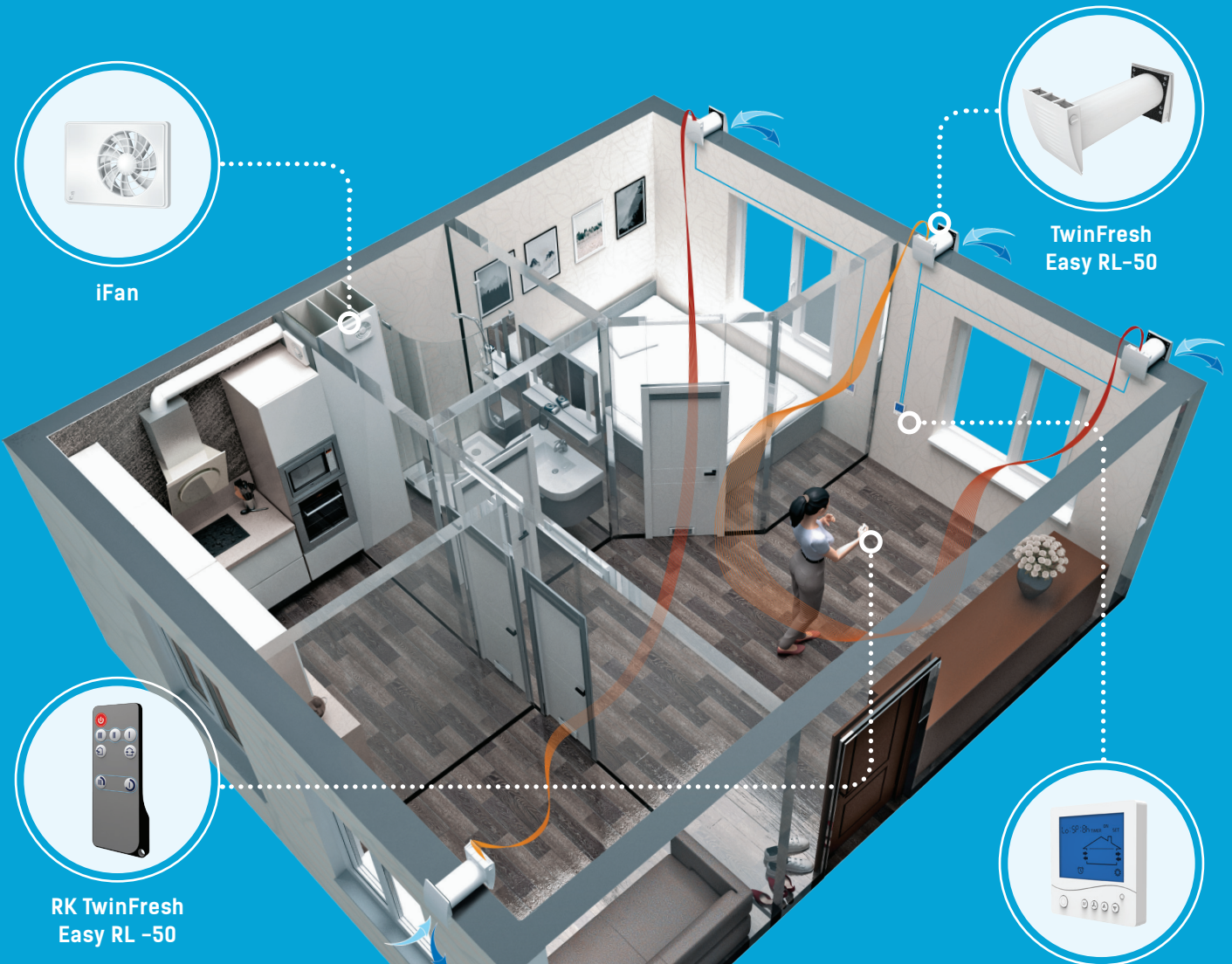

# INSTALLATION EXAMPLE

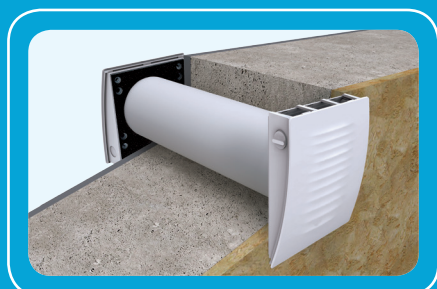

Mounting into a wall with a standard thickness using the EH-14 outer grille



Flush mounting using the angular mounting kit NP

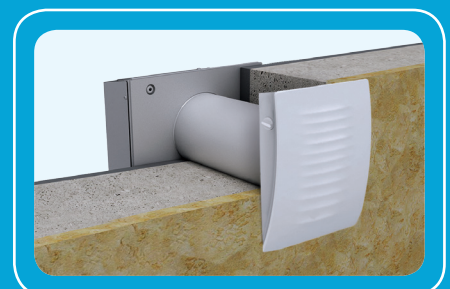

Mounting into a thin wall using the EH-2 outer hood

# ACCESSORIES



**SF TwinFresh Easy R-50 F8**  
F8 Filter

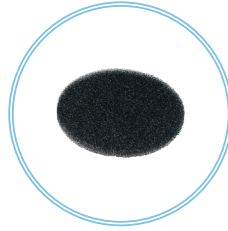

**SF TwinFresh Easy R-50 G3**  
G3 filter set (2 pcs.)



**MVM 152 bVsN**  
Round stainless steel  
outer hood



**MVMO 150 bV1s An**  
Round metal grille



**RK TwinFresh Easy RL-50**  
Remote control



**KV TwinFresh Easy RL-50**  
LCD control panel

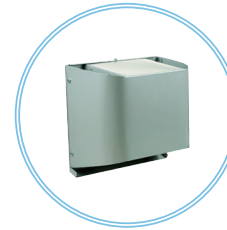

**EH-2 grey 160**  
Grey painted stainless steel  
outer hood for thin walls



**EH-2 chrome 160**  
Brushed stainless steel outer  
hood for thin walls

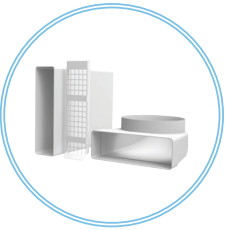

**NP white 160**  
Angular mounting kit



**NP chrome 160**  
Angular mounting kit

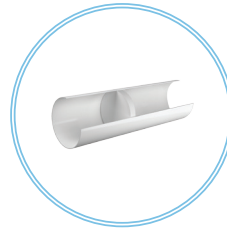

**Duct 160-500**  
Air duct 500 mm

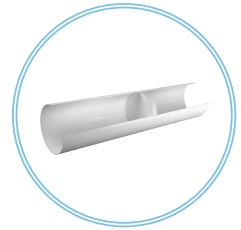

**Duct 160-700**  
Air duct 700 mm



**MVVM 162 05**  
Outer hood for mounting from indoor

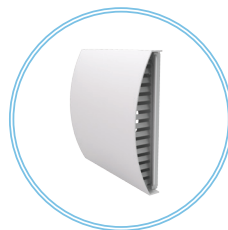

**EH-14 white 160**  
White plastic outer hood

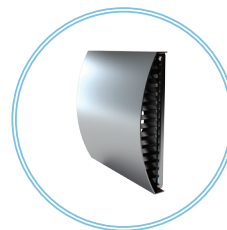

**EH-14 chrome 160**  
Grey plastic outer hood with a  
brushed stainless steel cover



**S3 TwinFresh**  
Cartridge for cold climate

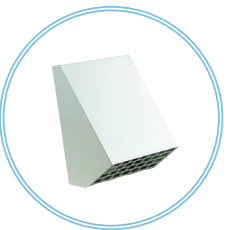

**EH-13 white 160**  
White painted aluminium outer  
hood for cold climate

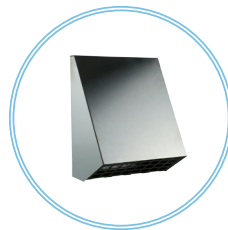

**EH-13 chrome 160**  
Brushed stainless steel outer  
hood for cold climate



Μιχαήλ Καραολή 19, τκ 143 43, Ν. Χαλκηδόνα, Αθήνα  
Τηλ: 211 - 70.55.500 & 210 - 21.30.051, Fax: 210 - 22.23.283



VENTS reserves the rights to modify any of its products' features, designs, components and specifications at any time and without notice to maintain the development and quality of manufactured goods.