

AXIAL FANS

Series
VENTS OV



Series
VENTS OVK



Series
VENTS VKF



Low pressure axial fans in the steel casing with the air flow up to **25000 m³/h** for wall and duct mounting

■ **Applications**

Combined supply and exhaust ventilation systems for various premises where high air flow at relatively low system resistance is required. OV and OVK fans can be used for the direct air exhaust or pressurization in smoke ventilation systems. OV and OVK fan are suitable for outdoor wall mounting.

■ **Design**

The fan casing and the impeller are made of steel with polymeric coating. OV and OVK fan terminal box is equipped with a cable for remote connection. VKF fan is fitted with the external terminal box mounted on the fan casing.

■ **Motor**

The impellers are powered by two-, four- or six-pole, single or three phase asynchronous motors with external rotor and built-in thermal overheating protection depending on the model. Ball bearings in the motor provide long service life designed for at least 40 000 hours. Motor protection rating IP44.

■ **Speed control**

Both smooth or step speed control is performed by means of the thyristor or autotransformer controller. Several fans can be connected to one controller if the total power and operating current do not exceed the rated controller values.

■ **Mounting**

Fan is installed on the wall surface by means of a square (OV series) or round (OVK series) mounting plate. VKF fan is installed into the duct by means of connecting flanges. The fan is powered through the external remote terminal box. Power supply and installation shall be performed in compliance with the manual and wiring diagram on the terminal box.

Designation key

Series and modification	Motor modification		Dimension type
	Number of poles	Phase	
VENTS OV: square mounting plate	2	E: single phase D: three phase	200; 250; 300; 350; 400; 450; 500; 550; 630, 710, 800
VENTS OVK: round mounting plate	4		
VENTS VKF: mounting into a vent duct	6		
	8		

Accessories



Flexible connector



Speed controllers

ErP data	
Overall efficiency	η [%]
Measurement category	MC
Efficiency category	EC
Efficiency grade	N
Variable speed drive	VSD
Power	kW
Current	A
Air flow	m ³ /h
Static pressure	Pa
Speed	n/min ⁻¹
Specific ratio	SR

Technical data

	OV/OVK/VKF 2E 200		OV/OVK/VKF 2E 250		OV/OVK/VKF 4E 250		OV/OVK/VKF 2E 300	
Voltage [V]	1~230		1~230		1~230		1~230	
Frequency [Hz]	50	60	50	60	50	60	50	60
Power [W]	55	61	80	91	50	56	145	178
Current [A]	0.26	0.28	0.4	0.42	0.22	0.24	0.66	0.79
Max. air flow [m³/h]	860	875	1050	1150	800	865	2230	2280
RPM [min ⁻¹]	2300	2550	2400	2990	1380	1730	2300	2410
Noise level at 3 m [dBA]	48	49	50	51	38	39	53	54
Transported air temperature [°C]	-30 +60	-30 +50	-30 +60	-30 +50	-30 +60	-30 +50	-30 +60	-30 +50
Protection rating	IP24 VKF IPX4		IP24 VKF IPX4		IP24 VKF IPX4		IP24 VKF IPX4	

	OV/OVK/VKF 4E 300		OV/OVK/VKF 4E 350		OV/OVK/VKF 4E 400		OV/OVK/VKF 4E 450	
Voltage [V]	1~230		1~230		1~230		1~230	
Frequency [Hz]	50	60	50	60	50	60	50	60
Power [W]	75	92	140	147	180	240	250	325
Current [A]	0.35	0.4	0.65	0.66	0.82	1.08	1.2	1.46
Max. air flow [m³/h]	1340	1475	2500	2650	3580	3890	4680	4790
RPM [min ⁻¹]	1350	1405	1380	1700	1380	1655	1350	1600
Noise level at 3 m [dBA]	44	45	46	47	53	54	56	57
Transported air temperature [°C]	-30 +60	-30 +50	-30 +60	-30 +50	-30 +60	-30 +50	-30 +60	-30 +50
Protection rating	IP24 VKF IPX4		IP24 VKF IPX4		IP24 VKF IPX4		IP24 VKF IPX4	

	OV/OVK/VKF 6E 450		OV/OVK/VKF 4E 500		OV/OVK/VKF 6E 500		OV/OVK/VKF 4E 550	
Voltage [V]	1~230		1~230		1~230		1~230	
Frequency [Hz]	50	60	50	60	50	60	50	60
Power [W]	151	161	420	455	220	268	550	654
Current [A]	0.78	0.8	1.95	2.05	1.1	1.22	2.55	2.88
Max. air flow [m³/h]	3200	3250	7060	7130	4880	5380	8800	8970
RPM [min ⁻¹]	945	1115	1300	1630	945	1105	1300	1580
Noise level at 3 m [dBA]	52	52	58	59	56	56	62	63
Transported air temperature [°C]	-30 +60	-30 +50	-30 +60	-30 +50	-30 +60	-30 +50	-30 +60	-30 +50
Protection rating	IP24 VKF IPX4		IP24 VKF IPX4		IP24 VKF IPX4		IP24 VKF IPX4	

	OV/OVK/VKF 6E 550		OV/OVK/VKF 4E 630		OV/OVK/VKF 6E 630	
Voltage [V]	1~230		1~230		1~230	
Frequency [Hz]	50	60	50	60	50	60
Power [W]	330	375	750	979	540	610
Current [A]	1.6	1.63	3.5	4.26	2.4	2.74
Max. air flow [m³/h]	6400	6520	11900	12100	10900	10990
RPM [min ⁻¹]	950	1060	1360	1625	850	1075
Noise level at 3 m [dBA]	58	58	67	68	59	59
Transported air temperature [°C]	-30 +60	-30 +50	-30 +60	-30 +50	-30 +60	-30 +50
Protection rating	IP24 VKF IPX4		IP24 VKF IPX4		IP24 VKF IPX4	

 VENTS OV
 VENTS OVK
 VENTS VKF
 FAN SERIES

AXIAL FANS
Technical data

	OV/OVK/VKF 2D 250		OV/OVK/VKF 4D 250		OV/OVK/VKF 2D 300		OV/OVK/VKF 4D 300	
Voltage [V]	3~400		3~400		3~400		3~400	
Frequency [Hz]	50	60	50	60	50	60	50	60
Power [W]	80	92	60	89	145	165	75	94
Current [A]	0.22	0.24	0.17	0.22	0.25	0.29	0.22	0.25
Max. air flow [m³/h]	1060	1150	850	885	2310	2390	1310	1530
RPM [min ⁻¹]	2600	3030	1400	1750	2350	2570	1380	1640
Noise level at 3 m [dBA]	51	52	38	38	52	52	45	45
Transported air temperature [°C]	-30 +60	-30 +50	-30 +60	-30 +50	-30 +60	-30 +50	-30 +60	-30 +50
Protection rating	IP24 VKF IPX4		IP24 VKF IPX4		IP24 VKF IPX4		IP24 VKF IPX4	

	OV/OVK/VKF 4D 350		OV/OVK/VKF 4D 400		OV/OVK/VKF 4D 450		OV/OVK/VKF 6D 450	
Voltage [V]	3~400		3~400		3~400		3~400	
Frequency [Hz]	50	60	50	60	50	60	50	60
Power [W]	140	150	180	195	250	275	148	175
Current [A]	0.38	0.41	0.47	0.55	0.6	0.65	0.42	0.47
Max. air flow [m³/h]	2520	2590	3740	3870	5280	5350	3500	3580
RPM [min ⁻¹]	1380	1640	1380	1625	1360	1620	900	1050
Noise level at 3 m [dBA]	46	46	54	54	56	56	53	53
Transported air temperature [°C]	-30 +60	-30 +50	-30 +60	-30 +50	-30 +60	-30 +50	-30 +60	-30 +50
Protection rating	IP24 VKF IPX4		IP24 VKF IPX4		IP24 VKF IPX4		IP24 VKF IPX4	

	OV/OVK/VKF 4D 500		OV/OVK/VKF 6D 500		OV/OVK/VKF 4D 550		OV/OVK/VKF 6D 550	
Voltage [V]	3~400		3~400		3~400		3~400	
Frequency [Hz]	50	60	50	60	50	60	50	60
Power [W]	450	370	230	281	750	600	337	447
Current [A]	0.9	0.7	0.58	0.59	1.5	1.1	0.9	0.95
Max. air flow [m³/h]	6570	6230	4900	5430	9700	7380	6400	6520
RPM [min ⁻¹]	1300	1605	920	1015	1350	1605	910	1020
Noise level at 3 m [dBA]	60	60	57	57	64	64	61	61
Transported air temperature [°C]	-30 +60	-30 +50	-30 +60	-30 +50	-30 +60	-30 +50	-30 +60	-30 +50
Protection rating	IP24 VKF IPX4		IP24 VKF IPX4		IP24 VKF IPX4		IP24 VKF IPX4	

	OV/OVK/VKF 4D 630		OV/OVK/VKF 6D 630		OV/OVK/ VKF 6D 710	OV/OVK/ VKF 8D 710	OV/OVK/ VKF 6D 800	OV/OVK/ VKF 8D 800
Voltage [V]	3~400		3~400		3~400	3~400	3~400	3~400
Frequency [Hz]	50	60	50	60	50	50	50	50
Power [W]	800	910	550	716	1150	700	1850	700
Current [A]	1.6	1.68	1.45	1.56	2.0	1.5	3.7	1.7
Max. air flow [m³/h]	12200	12400	10950	11120	15440	12000	25000	15550
RPM [min ⁻¹]	1320	1585	900	1060	830	710	915	710
Noise level at 3 m [dBA]	69	69	59	59	63	61	67	66
Transported air temperature [°C]	-30 +60	-30 +50	-30 +60	-30 +50	-30 +60	-30 +60	-30 +60	-30 +60
Protection rating	IP24 VKF IPX4		IP24 VKF IPX4		IP24 VKF IPX4	IP24 VKF IPX4	IP24 VKF IPX4	IP24 VKF IPX4

Fan overall dimensions

Type	Dimensions [mm]					Mass [kg]
	ØD	Ød	B	B1	L	
OV 2E 200	210	7	312	260	125	3.0
OV 2E 250/OV 2D 250	260	7	370	320	135	4.0
OV 4E 250/OV 4D 250	260	7	370	320	135	3.5
OV 2E 300/OV 4D 300	317	9	430	380	145	6.1/5.4
OV 4E 300/OV 4D 300	317	9	430	380	145	5.0/5.4
OV 4E 350/OV 4D 350	374	9	485	435	165	7.8
OV 4E 400/OV 4D 400	416	9	540	490	220	8.8
OV 4E 450/OV 4D 450/OV 6E 450/OV 6D 450	465	11	576	535	230	10.5
OV 4E 500/OV 4D 500/OV 6E 500/OV 6D 500	520	11	655	615	250	14.0
OV 4E 550/OV 4D 550/OV 6E 550/OV 6D 550	570	11	725	675	260	16.5
OV 4E 630/OV 4D 630/OV 6E 630/OV 6D 630	650	11	800	710	275	20.0
OV 6D 710/OV 8D 710	725	13	900	810	350	33.0
OV 6D 800/OV 8D 800	800	13	970	910	350	44.0

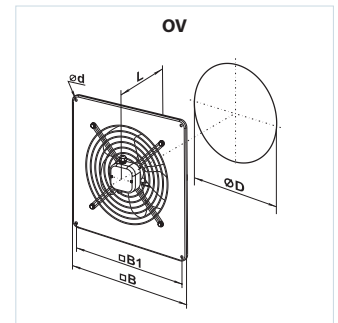

Type	Dimensions [mm]					Mass [kg]
	ØD	ØD1	ØD2	Ød	L	
OVK 2E 200	210	250	280	7	125	2.8
OVK 2E 250/OVK 2D 250	260	295	340	7	135	3.8
OVK 4E 250/OVK 4D 250	260	295	340	7	135	3.4
OVK 2E 300/OVK 2D 300	317	380	397	9	145	5.9/5.1
OVK 4E 300/OVK 4D 300	317	380	397	9	145	5.0/5.1
OVK 4E 350/OVK 4D 350	374	442	460	9	165	7.5
OVK 4E 400/OVK 4D 400	417	504	528	9	220	8.5
OVK 4E 450/OVK 4D 450/OVK 6E 450/OVK 6D 450	465	578	607	11	230	10.0
OVK 4E 500/OVK 4D 500/OVK 6E 500/OVK 6D 500	520	590	655	11	250	14.0
OVK 4E 550/OVK 4D 550/OVK 6E 550/OVK 6D 550	570	645	710	11	260	16.5
OVK 4E 630/OVK 4D 630/OVK 6E 630/OVK 6D 630	650	760	800	11	275	20.0
OVK 6D 710/OVK 8D 710	725	820	890	13	350	31.0
OVK 6D 800/OVK 8D 800	800	900	970	13	350	42.0

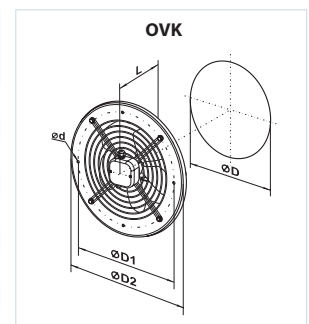

 VENTS OV
 VENTS OVK
 VENTS VKF
 FAN SERIES

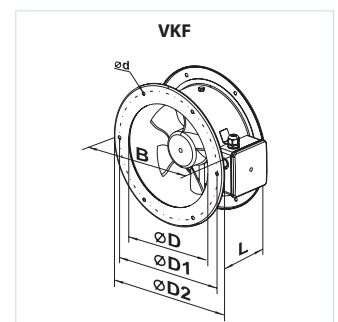
Type	Dimensions [mm]						Mass [kg]
	ØD	ØD1	ØD2	Ød	B	L	
VKF 2E 200	205	235	255	7	290	120	3.0
VKF 2E 250/VKF 2D 250	260	286	306	7	340	150	3.9
VKF 4E 250/VKF 4D 250	260	286	306	7	340	150	4.0
VKF 2E 300/VKF 2D 300	310	356	382	7	410	160	6.2/5.7
VKF 4E 300/VKF 4D 300	310	356	382	7	410	160	6.2
VKF 4E 350/VKF 4D 350	362	395	421	9.5	450	160	7.7
VKF 4E 400/VKF 4D 400	412	438	465	9.5	500	170	8.1
VKF 4E 450/VKF 4D 450/VKF 6E 450/VKF 6D 450	462	487	515	9.5	550	200	9.1
VKF 4E 500/VKF 4D 500/VKF 6E 500/VKF 6D 500	515	541	570	9.5	600	220	11.0
VKF 4E 550/VKF 4D 550/VKF 6E 550/VKF 6D 550	565	605	636	11.5	660	230	13.9
VKF 4E 630/VKF 4D 630/VKF 6E 630/VKF 6D 630	645	674	715	11.5	740	250	16.4
VKF 6D 710/VKF 8D 710	725	767	805	11.5	835	250	30.0
VKF 6D 800/VKF 8D 800	800	845	880	11.5	910	280	40.0

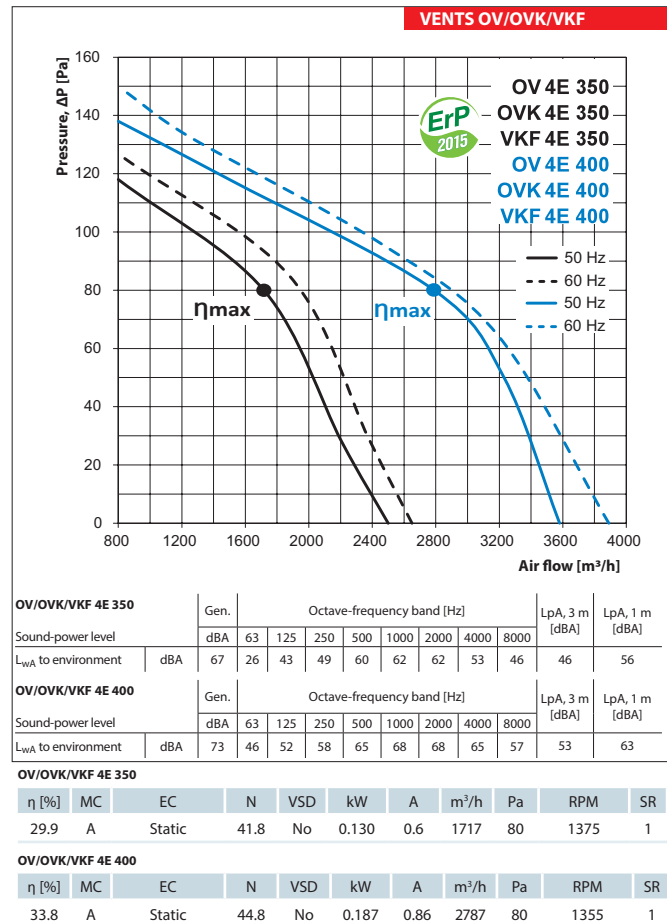
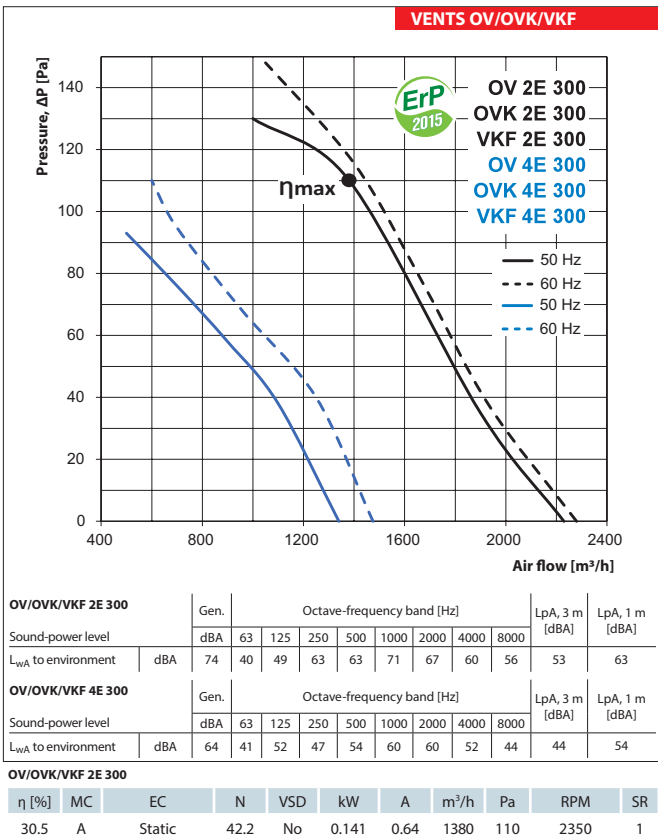
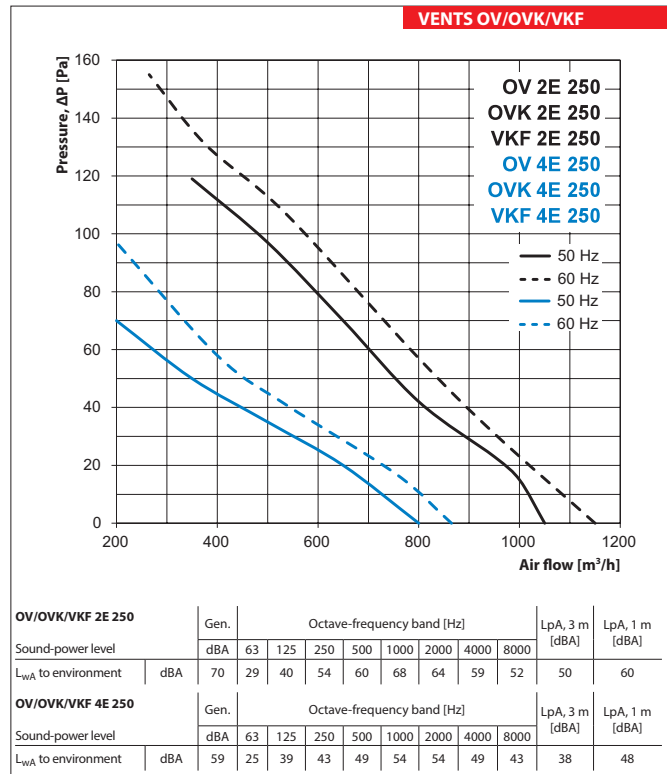
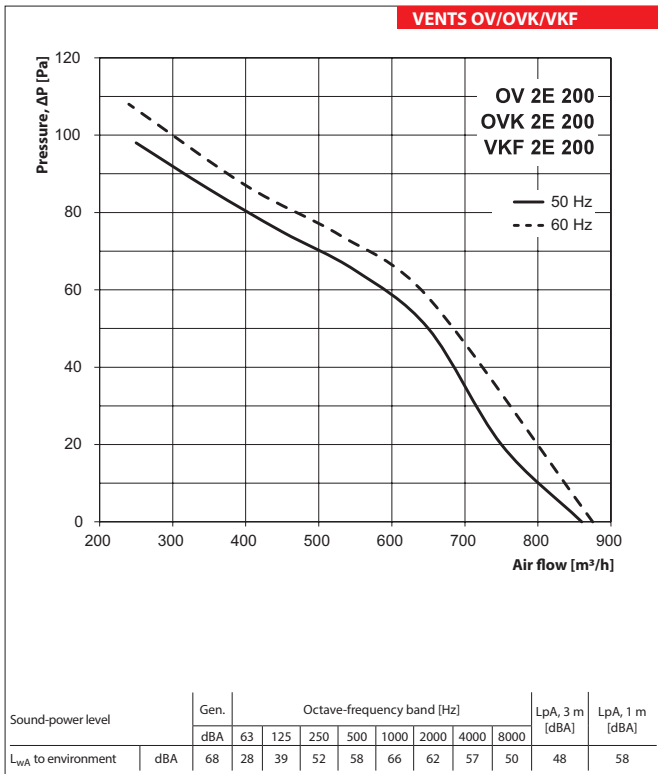

AXIAL FANS

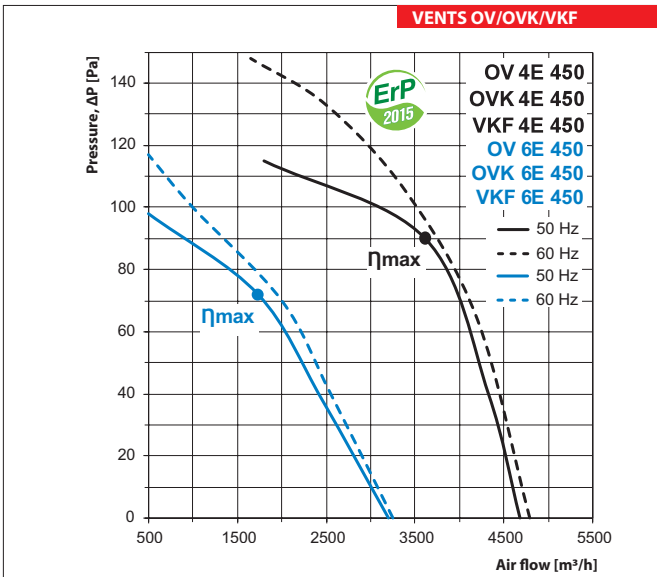



OV/OVK/VKF 4E 450		Gen.	Octave-frequency band [Hz]								LpA, 3 m [dBA]	LpA, 1 m [dBA]
Sound-power level	dBA	63	125	250	500	1000	2000	4000	8000			
L _{WA} to environment	dBA	76	46	57	64	70	72	70	66	58	56	66

OV/OVK/VKF 6E 450		Gen.	Octave-frequency band [Hz]								LpA, 3 m [dBA]	LpA, 1 m [dBA]
Sound-power level	dBA	63	125	250	500	1000	2000	4000	8000			
L _{WA} to environment	dBA	72	45	51	57	64	67	67	64	56	52	62

η [%]	MC	EC	N	VSD	kW	A	m³/h	Pa	RPM	SR
32.0	A	Static	41.8	No	0.288	1.31	3610	90	1270	1

η [%]	MC	EC	N	VSD	kW	A	m³/h	Pa	RPM	SR
28.3	A	Static	37.2	No	0.139	0.7	1733	72	910	1

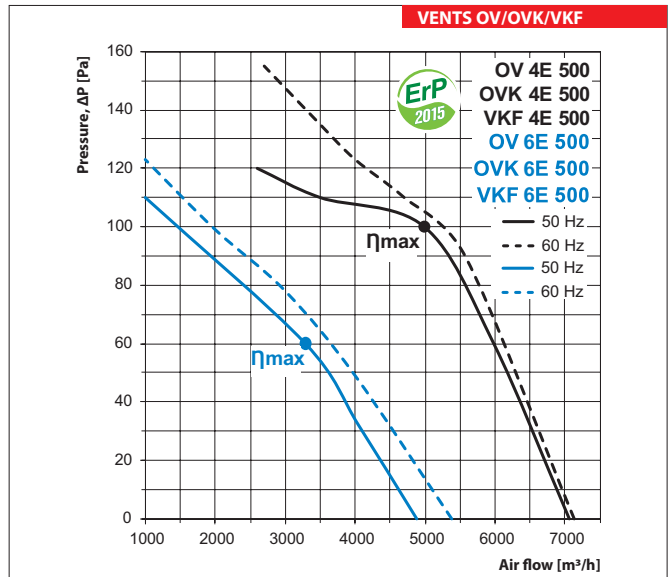

OV/OVK/VKF 4E 500		Gen.	Octave-frequency band [Hz]								LpA, 3 m [dBA]	LpA, 1 m [dBA]
Sound-power level	dBA	63	125	250	500	1000	2000	4000	8000			
L _{WA} to environment	dBA	79	49	60	67	73	74	73	68	60	58	68

OV/OVK/VKF 6E 500		Gen.	Octave-frequency band [Hz]								LpA, 3 m [dBA]	LpA, 1 m [dBA]
Sound-power level	dBA	63	125	250	500	1000	2000	4000	8000			
L _{WA} to environment	dBA	76	46	58	64	70	72	70	66	59	56	66

η [%]	MC	EC	N	VSD	kW	A	m³/h	Pa	RPM	SR
32.1	A	Static	40.7	No	0.440	2.01	4987	100	1285	1

η [%]	MC	EC	N	VSD	kW	A	m³/h	Pa	RPM	SR
30.1	A	Static	41.1	No	0.186	0.86	3288	60	900	1

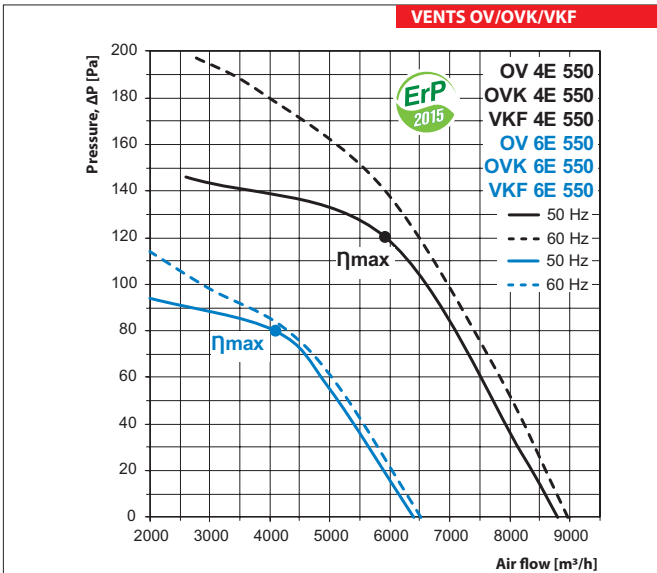

OV/OVK/VKF 4E 550		Gen.	Octave-frequency band [Hz]								LpA, 3 m [dBA]	LpA, 1 m [dBA]
Sound-power level	dBA	63	125	250	500	1000	2000	4000	8000			
L _{WA} to environment	dBA	83	52	64	71	77	78	77	72	64	62	72

OV/OVK/VKF 6E 550		Gen.	Octave-frequency band [Hz]								LpA, 3 m [dBA]	LpA, 1 m [dBA]
Sound-power level	dBA	63	125	250	500	1000	2000	4000	8000			
L _{WA} to environment	dBA	79	50	61	68	72	73	74	69	60	58	68

η [%]	MC	EC	N	VSD	kW	A	m³/h	Pa	RPM	SR
34.7	A	Static	42.6	No	0.581	2.64	5919	120	1240	1

η [%]	MC	EC	N	VSD	kW	A	m³/h	Pa	RPM	SR
33.3	A	Static	43.1	No	0.279	1.34	4087	80	910	1

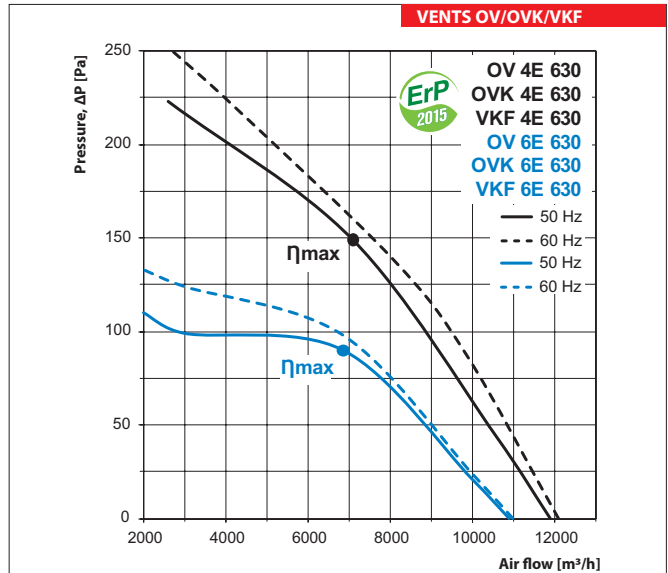

OV/OVK/VKF 4E 630		Gen.	Octave-frequency band [Hz]								LpA, 3 m [dBA]	LpA, 1 m [dBA]
Sound-power level	dBA	63	125	250	500	1000	2000	4000	8000			
L _{WA} to environment	dBA	88	57	68	76	81	83	82	77	69	67	77

OV/OVK/VKF 6E 630		Gen.	Octave-frequency band [Hz]								LpA, 3 m [dBA]	LpA, 1 m [dBA]
Sound-power level	dBA	63	125	250	500	1000	2000	4000	8000			
L _{WA} to environment	dBA	80	51	62	69	74	75	73	67	59	59	69

η [%]	MC	EC	N	VSD	kW	A	m³/h	Pa	RPM	SR
37.5	A	Static	44.4	No	0.800	3.76	7095	149	1290	1

η [%]	MC	EC	N	VSD	kW	A	m³/h	Pa	RPM	SR
35	A	Static	43.3	No	0.500	2.55	6857	90	915	1

VENTS OV
VENTS OVK
VENTS VKF
FAN SERIES

AXIAL FANS

VENTS OV/OVK/VKF

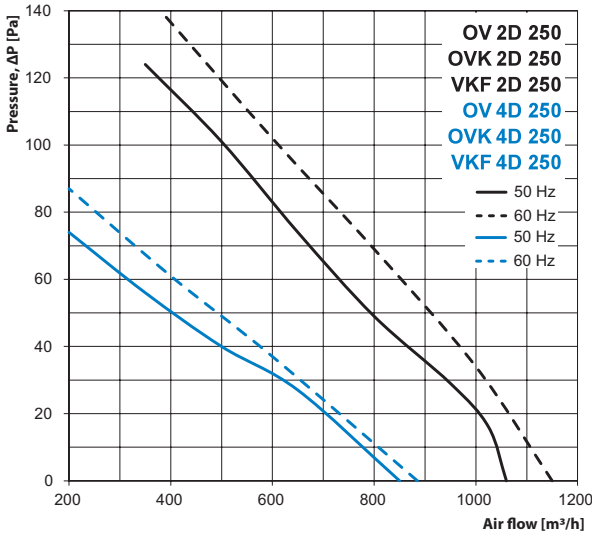

OV/OVK/VKF 2D 250	Gen.	Octave-frequency band [Hz]								LpA, 3 m [dBA]	LpA, 1 m [dBA]	
		dBA	63	125	250	500	1000	2000	4000			8000
Sound-power level	dBA	71	29	41	55	61	69	65	60	52	51	61
L _{WA} to environment	dBA	71	29	41	55	61	69	65	60	52	51	61

OV/OVK/VKF 4D 250	Gen.	Octave-frequency band [Hz]								LpA, 3 m [dBA]	LpA, 1 m [dBA]	
		dBA	63	125	250	500	1000	2000	4000			8000
Sound-power level	dBA	59	25	39	43	49	54	54	49	43	38	48
L _{WA} to environment	dBA	59	25	39	43	49	54	54	49	43	38	48

VENTS OV/OVK/VKF

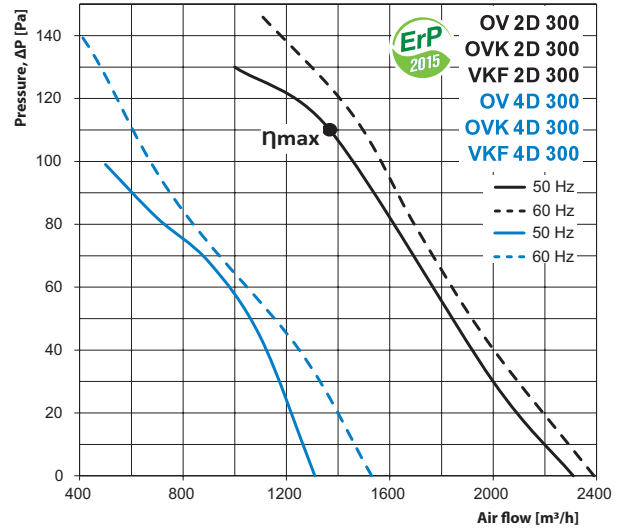

OV/OVK/VKF 2D 300	Gen.	Octave-frequency band [Hz]								LpA, 3 m [dBA]	LpA, 1 m [dBA]	
		dBA	63	125	250	500	1000	2000	4000			8000
Sound-power level	dBA	73	39	48	62	62	70	66	60	55	52	62
L _{WA} to environment	dBA	73	39	48	62	62	70	66	60	55	52	62

OV/OVK/VKF 4D 300	Gen.	Octave-frequency band [Hz]								LpA, 3 m [dBA]	LpA, 1 m [dBA]	
		dBA	63	125	250	500	1000	2000	4000			8000
Sound-power level	dBA	65	42	53	46	55	61	61	53	44	45	55
L _{WA} to environment	dBA	65	42	53	46	55	61	61	53	44	45	55

OV/OVK/VKF 2D 300	η [%]	MC	EC	N	VSD	kW	A	m³/h	Pa	RPM	SR
	30.3	A	Static	42	No	0.141	0.25	1367	110	2350	1

VENTS OV/OVK/VKF

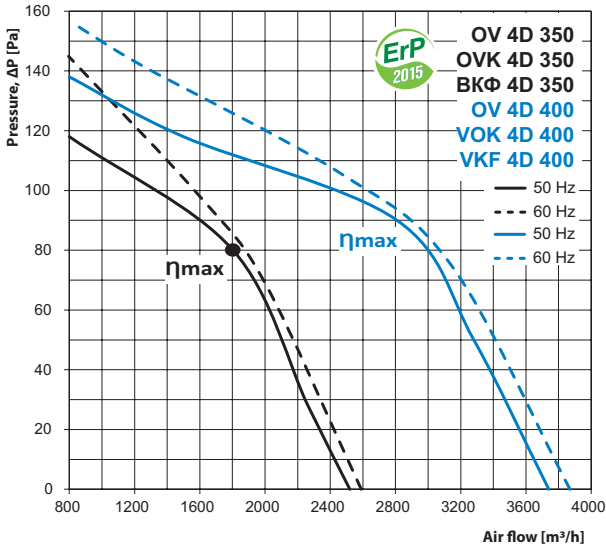

OV/OVK/VKF 4D 350	Gen.	Octave-frequency band [Hz]								LpA, 3 m [dBA]	LpA, 1 m [dBA]	
		dBA	63	125	250	500	1000	2000	4000			8000
Sound-power level	dBA	66	26	43	48	59	62	62	53	46	46	56
L _{WA} to environment	dBA	66	26	43	48	59	62	62	53	46	46	56

OV/OVK/VKF 4D 400	Gen.	Octave-frequency band [Hz]								LpA, 3 m [dBA]	LpA, 1 m [dBA]	
		dBA	63	125	250	500	1000	2000	4000			8000
Sound-power level	dBA	74	31	48	58	63	70	70	66	58	54	64
L _{WA} to environment	dBA	74	31	48	58	63	70	70	66	58	54	64

OV/OVK/VKF 4D 350	η [%]	MC	EC	N	VSD	kW	A	m³/h	Pa	RPM	SR
	31.7	A	Static	43.7	No	0.129	0.37	1802	80	1400	1

OV/OVK/VKF 4D 400	η [%]	MC	EC	N	VSD	kW	A	m³/h	Pa	RPM	SR
	34.3	A	Static	44.9	No	0.209	0.47	2807	90	1365	1

VENTS OV/OVK/VKF

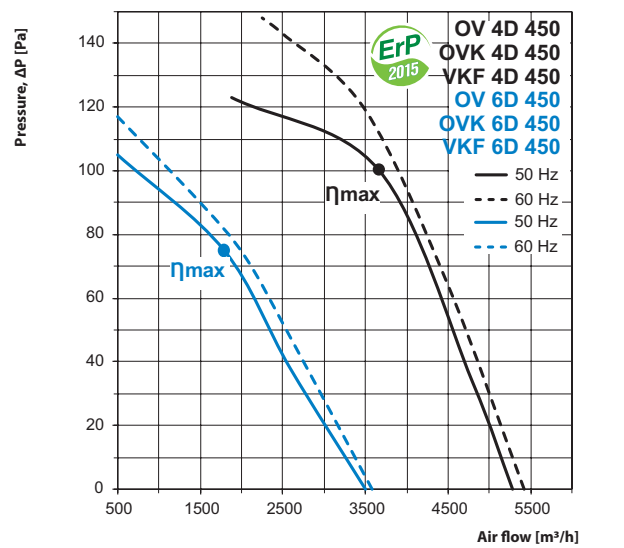

OV/OVK/VKF 4D 450	Gen.	Octave-frequency band [Hz]								LpA, 3 m [dBA]	LpA, 1 m [dBA]	
		dBA	63	125	250	500	1000	2000	4000			8000
Sound-power level	dBA	77	48	60	67	70	71	72	67	59	56	66
L _{WA} to environment	dBA	77	48	60	67	70	71	72	67	59	56	66

OV/OVK/VKF 6D 450	Gen.	Octave-frequency band [Hz]								LpA, 3 m [dBA]	LpA, 1 m [dBA]	
		dBA	63	125	250	500	1000	2000	4000			8000
Sound-power level	dBA	73	44	55	61	67	69	67	63	56	53	63
L _{WA} to environment	dBA	73	44	55	61	67	69	67	63	56	53	63

OV/OVK/VKF 4D 450	η [%]	MC	EC	N	VSD	kW	A	m³/h	Pa	RPM	SR
	35.1	A	Static	44.8	No	0.296	0.59	3659	100	1310	1

OV/OVK/VKF 6D 450	η [%]	MC	EC	N	VSD	kW	A	m³/h	Pa	RPM	SR
	28.4	A	Static	37.9	No	0.145	0.4	1790	75	900	1

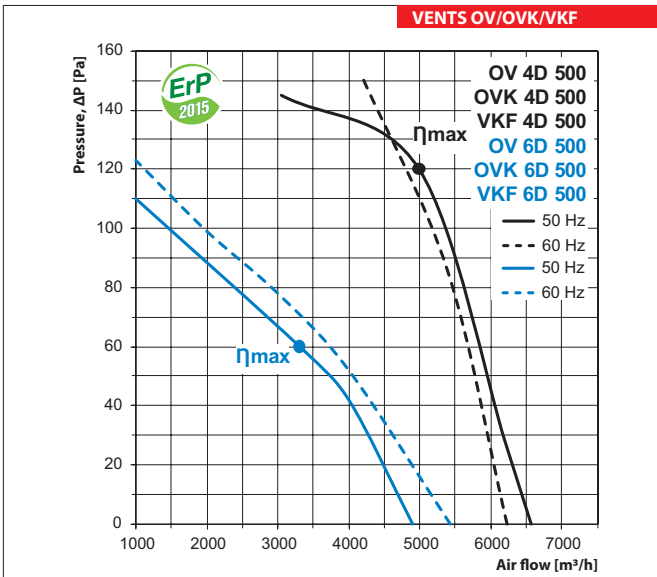

OV/OVK/VKF 4D 500		Gen.	Octave-frequency band [Hz]								LpA, 3 m [dBA]	LpA, 1 m [dBA]
Sound-power level	dBA	63	125	250	500	1000	2000	4000	8000			
L _{WA} to environment	dBA	81	51	63	70	74	75	76	71	62	60	70

OV/OVK/VKF 6D 500		Gen.	Octave-frequency band [Hz]								LpA, 3 m [dBA]	LpA, 1 m [dBA]
Sound-power level	dBA	63	125	250	500	1000	2000	4000	8000			
L _{WA} to environment	dBA	78	48	59	66	72	73	72	67	59	57	67

OV/OVK/VKF 4D 500	η [%]	MC	EC	N	VSD	kW	A	m³/h	Pa	RPM	SR
	35.5	A	Static	43.9	No	0.478	0.9	4988	120	1305	1

OV/OVK/VKF 6D 500	η [%]	MC	EC	N	VSD	kW	A	m³/h	Pa	RPM	SR
	30.5	A	Static	41.5	No	0.185	0.47	3308	60	915	1

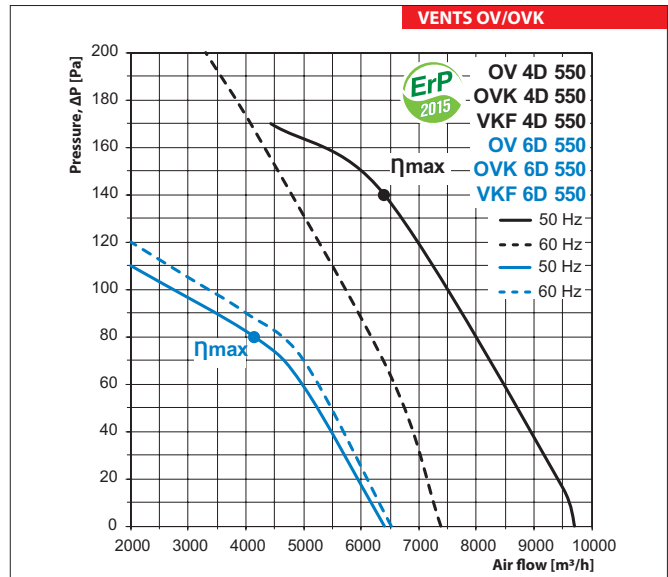

OV/OVK/VKF 4D 550		Gen.	Octave-frequency band [Hz]								LpA, 3 m [dBA]	LpA, 1 m [dBA]
Sound-power level	dBA	63	125	250	500	1000	2000	4000	8000			
L _{WA} to environment	dBA	85	53	65	72	79	80	79	73	65	64	74

OV/OVK/VKF 6D 550		Gen.	Octave-frequency band [Hz]								LpA, 3 m [dBA]	LpA, 1 m [dBA]
Sound-power level	dBA	63	125	250	500	1000	2000	4000	8000			
L _{WA} to environment	dBA	82	51	63	70	76	77	76	71	63	61	71

OV/OVK/VKF 4D 550	η [%]	MC	EC	N	VSD	kW	A	m³/h	Pa	RPM	SR
	38.8	A	Static	46.3	No	0.656	1.27	6400	140	1175	1

OV/OVK/VKF 6D 550	η [%]	MC	EC	N	VSD	kW	A	m³/h	Pa	RPM	SR
	34.4	A	Static	44.3	No	0.273	0.74	4142	80	920	1

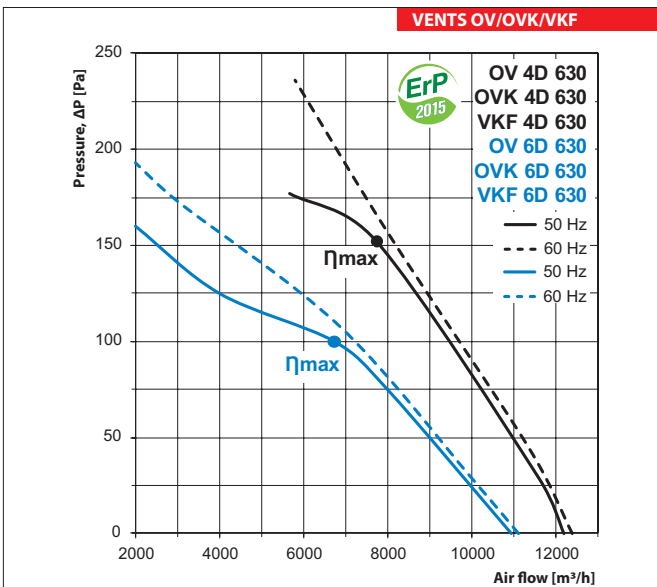

OV/OVK/VKF 4D 630		Gen.	Octave-frequency band [Hz]								LpA, 3 m [dBA]	LpA, 1 m [dBA]
Sound-power level	dBA	63	125	250	500	1000	2000	4000	8000			
L _{WA} to environment	dBA	90	58	69	78	83	85	84	79	70	69	79

OV/OVK/VKF 6D 630		Gen.	Octave-frequency band [Hz]								LpA, 3 m [dBA]	LpA, 1 m [dBA]
Sound-power level	dBA	63	125	250	500	1000	2000	4000	8000			
L _{WA} to environment	dBA	80	51	61	69	73	75	74	70	62	59	69

OV/OVK/VKF 4D 630	η [%]	MC	EC	N	VSD	kW	A	m³/h	Pa	RPM	SR
	41.2	A	Static	48.1	No	0.810	1.61	7743	152	1290	1

OV/OVK/VKF 6D 630	η [%]	MC	EC	N	VSD	kW	A	m³/h	Pa	RPM	SR
	37.0	A	Static	45.2	No	0.515	1.33	6737	100	920	1

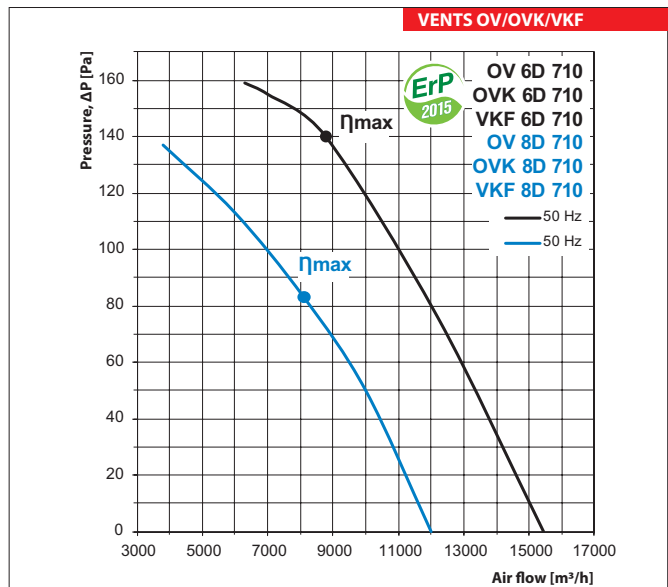

OV/OVK/VKF 6D 710		Gen.	Octave-frequency band [Hz]								LpA, 3 m [dBA]	LpA, 1 m [dBA]
Sound-power level	dBA	63	125	250	500	1000	2000	4000	8000			
L _{WA} to environment	dBA	83	54	65	72	78	79	77	70	62	63	73

OV/OVK/VKF 8D 710		Gen.	Octave-frequency band [Hz]								LpA, 3 m [dBA]	LpA, 1 m [dBA]
Sound-power level	dBA	63	125	250	500	1000	2000	4000	8000			
L _{WA} to environment	dBA	82	53	64	71	76	77	75	69	61	61	71

OV/OVK/VKF 6D 710	η [%]	MC	EC	N	VSD	kW	A	m³/h	Pa	RPM	SR
	35.6	A	Static	42	No	0.979	1.91	8777	140	830	1

OV/OVK/VKF 8D 710	η [%]	MC	EC	N	VSD	kW	A	m³/h	Pa	RPM	SR
	29.4	A	Static	37	No	0.648	1.48	8110	83	810	1

VENTS OV
VENTS OVK
VENTS VKF
FAN SERIES

AXIAL FANS

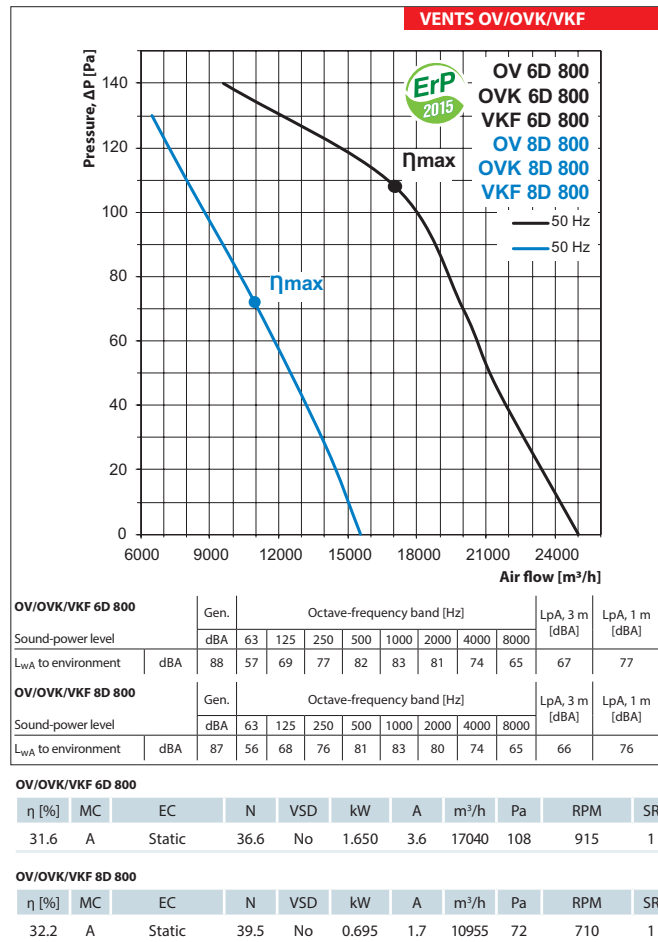



Μιχαήλ Καραολή 19, τκ 143 43, Ν. Χαλκηδόνα, Αθήνα
Τηλ: 211 - 70.55.500 & 210 - 21.30.051, Fax: 210 - 22.23.283