



BFC

FANCOIL / Forward Curved

Fan Components and Material Properties

BFC double suction crossflow fans operate at high efficiency and low noise level. Manufactured from high quality galvanized steel resistant to corrosion. The motor and fan impeller are connected to the main body by aluminum carriers. The external rotor motor is used to create a compact structure and the device is max. It is capable of carrying air at a temperature of 40°C.

Fan Structure

The forward sloped fan wheel is made of high quality galvanized steel which is resistant to corrosion and they are manufactured in aerodynamic structure to ensure regular flow. Thanks to its aerodynamic wing structure, it works quietly.

Benefits

It works with low noise levels and is designed to be maintenance-free for long periods of time. It offers space saving according to its capacity. Due to its frequent wing structure and efficient motor, it produces high flow rate and pressure compared to its dimensions. Provides advantages in areas where space is limited. Speed can be adjusted with speed control devices.

Speed Control

Optional control devices can be provided.
* Speed control can be done with linear voltage regulator. (see BSC accessory)

Usage Areas

Fancoil devices, local cooling applications, low noise where desired and air conditioning devices are used for air circulation.

Accessories



BSC

Technical Drawing and Tables

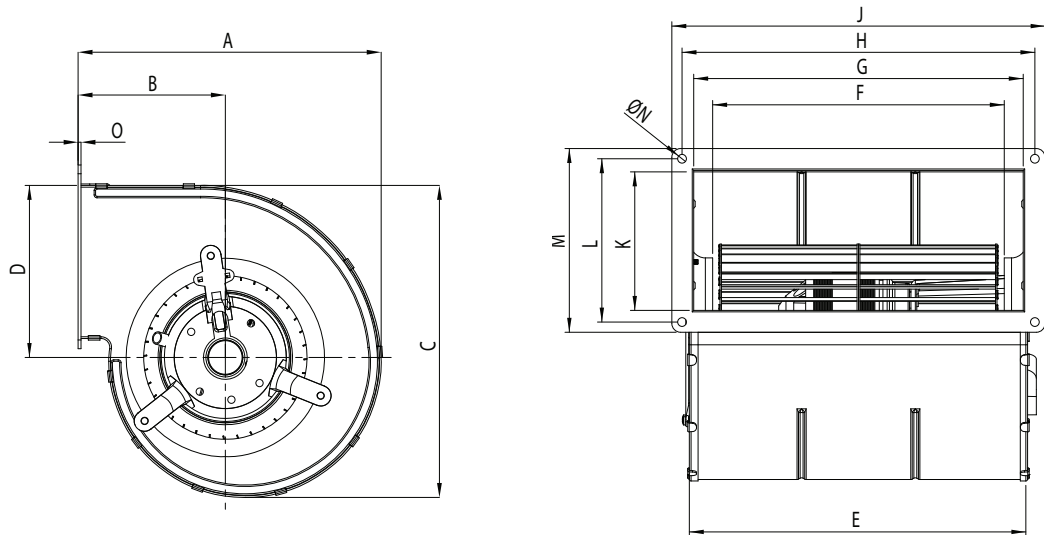

TYPE	A	B	C	D	E	F	G	H	J	K	L	M	N	O
BFC 133-146	208	101	214	118	231	200	226	242	256	95	112	126	06	2

Dimensions are in (mm)

TYPE	VOLTAGE	FREQUENCY	POWER	CURRENT	CAPACITOR	SPEED	AIR FLOW	SOUND PRESSURE	INSULATION CLASS	PROTECTION CLASS	WEIGHT
	V	Hz	W	(A)	(µF)	r.p.m	m³/h	dB(A)	Ins.cl.	IP	kg
BFC 133-2K	230	50/60	200/210	0,95/1	4	1300/1150	810/715	56	B	44	4,7
BFC 133-4K	230	50/60	95/110	0,42/0,49	3	1200/1150	750/720	55	B	44	4,7
BFC 146-2K	230	50/60	300/355	1,3/1,45	7	2000	1100	63	B	44	5
BFC 146-4K	230	50/60	95/115	0,42/0,50	3	1000/1130	775/875	62	B	44	5

Sound Level Measured from 3m distance in room condition.

